



Submersible Drainage & Sewage Pump 50Hz

Efficient discharge of sewage



STAIRS INDUSTRIAL CO., LTD.

Index

Submersible Drainage Pumps

Submersible Sewage/ Effluent Pump

STAIRS series Submersible Sewage / Effluent /Grinder

Pumps are designed for commercial and industrial wastewater transferring and dewatering applications.

The innovative vortex impeller design reduces the risk of clogging problem

. Moreover,

STAIRS series include a stainless steel /cast iron motor frame to prevent corrosion and are designed to provide great heat dissipation from the motor, ensuring a long service life.

As with STAIRS pump, each one is 100% tested to ensure quality and reliability for years of trouble-free performance.

Submersible Drainage Pumps

X1	01
XD	03
XV	05
HM	07
SD	09
SV	12
SVL	15
SVN	18
TS/TM/TL	21
GD	23



Model Code

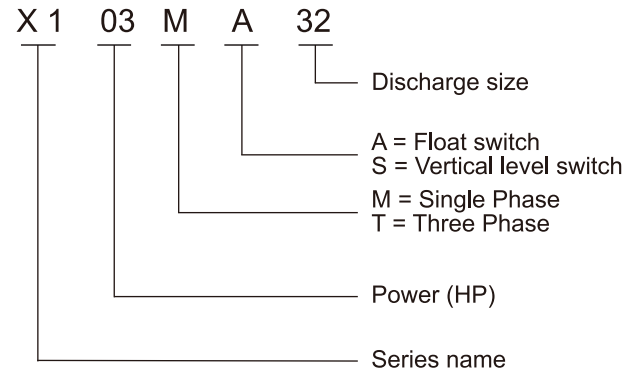

Feature

Compact design with Top Discharge Outlet reduces space usage for installation in small manholes, for use in domestic, installations and small featured works. Two different types of lever sensors :

- Mechanical activated float switch with cable extender (A)
- Vertical Mechanical activated Float Switch with casement (S)

Top discharged cools and removes heat from the motor through the outlet. It allows these pumps to be used even when only partially submerged. Every model undergoes hydrostatic testing for leakage from the casing and mechanical seals.

Applications

- Domestic drainage
- Grey water drainage.
- Koi pond
- Light waste water discharge.
- Hydro-sanitary
- Fountain and landscape
- Drainage pumping.
- Livestocks
- Emergencies flooding pumping

Motor Data

- Motor Type : 2 POLE , dry type
- Frequency : 50Hz
- Nominal Speed : 2850 rpm
- Insulation Class : F class (155°C)

Operation Conditions

- Fluid Temperature: 0 to 50°C (122°F)
- MAX.depth : Maximum 5M

Pump Data

- Enclosure Protection Class : IP 68
- Protection Device : Thermal Protector (Single phase)
- Insulation Class : F class (155°C)
- Bearing : Double sealed with steel cage
- Mechanical seal : unbalance single mechanical seal bath in oil with spring type oil seal

Material

No.	Component	Material
1	Cable	H05RN-F
2	Float switch	Plastic
3	Handle	NY66+G30
4	Motor cover	AISI 304
5	Motor housing	AISI 304
6	Oil Seal	NBR
7	Mechanical seal	Carbon Graphite Ceramic / NBR/ 304
8	Shaft	AISI 410
9	Pump housing	AISI 304
10	Impeller	AISI 304
11	Pump casing	AISI 304
12	Strainer	AISI 304
13	Spring washer	AISI 304
14	Hex Domed Nuts	AISI 304

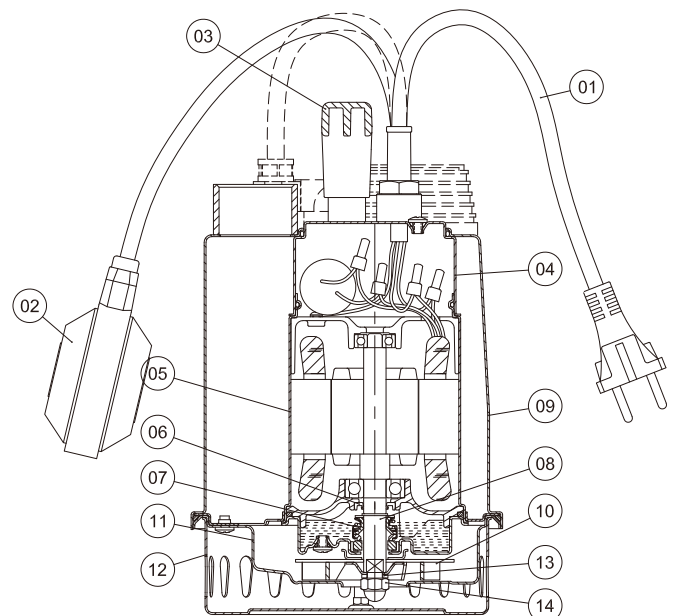

Performance Curves

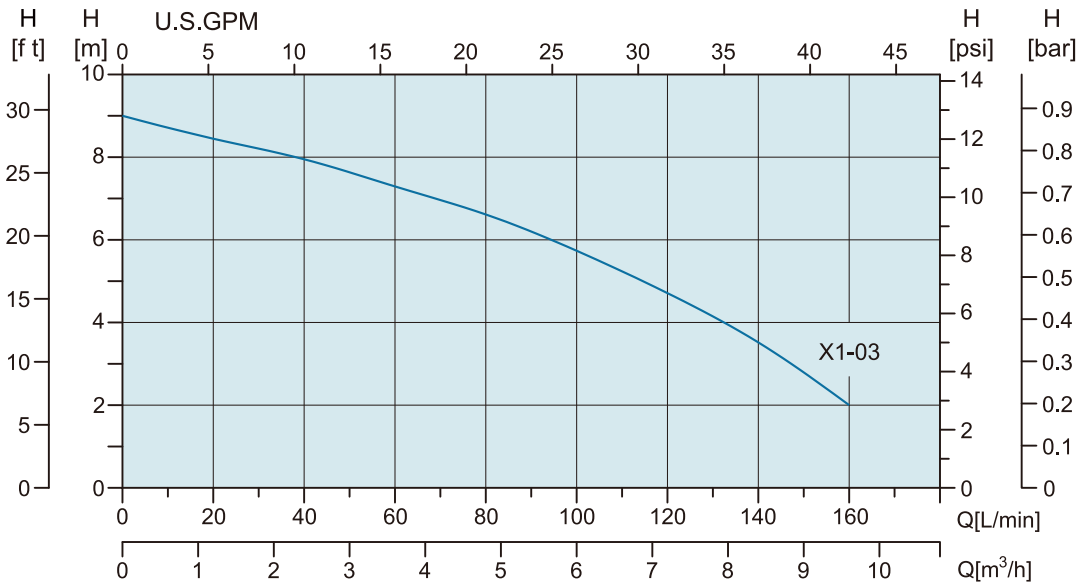

Technical Data

Single Phase

Model	Power		Current [A]	Capacitort	Head		Flow		Discharge
	HP	Kw			Rated (M)	Max (M)	Rated (L/min)	Max (L/min)	
X1 03M-32	0.33	0.25	1.9-1.7	8uF/450V	6.0	9.0	93	160	1 1/4"
X1 03MA-32									
X1 03MS-32									

Three Phase

Model	Power		Current [A]		Head		Flow		Discharge
	HP	Kw	220-240V	380-415V	Rated (M)	Max (M)	Rated (L/min)	Max (L/min)	
X1 03T-32	0.33	0.25	1.5-1.3	0.9-0.7	6.0	9.0	93	160	1 1/4"

Dimensions

Model	Discharge[mm]		Solid Passage [mm]	Cable		N.W. [kg]
	H	H1		H05 RN-F	M	
X1 03M-32	274	231	10	3G0.75mm²	10	5.4
X1 03MA-32						5.7
X1 03MS-32						5.8
X1 03T-32	274	231	10	4G0.75mm²	10	5.4

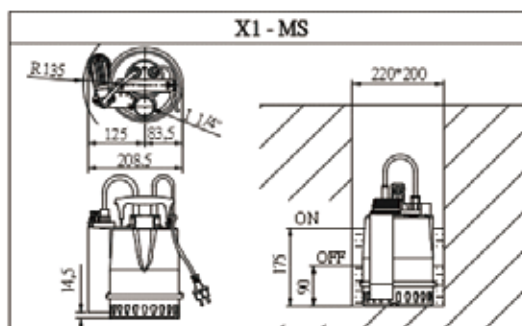
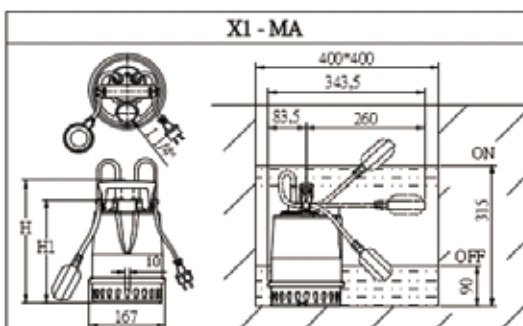



Model Code

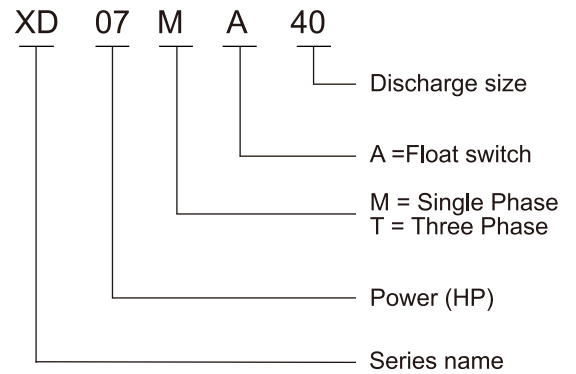

Applications

- Basement water removal
- Waste water drainage
- Water transfer
- Sump/effluent handling
- Dewatering
- Fish pond & fountain circulation
- Factory waste water handling

Motor Data

- Motor Type : 2 POLE , dry type
- Frequency : 50Hz
- Nominal Speed : 2850 rpm
- Insulation Class : F class (155°C)
- Enclosure Protection Class : IP 68
- Protection Device :
Thermal Protector (Single phase)

Pump Data

- Impeller : Open Impeller
- Shaft Seal / Mechanical :
Double Seals
- Bearing :
Double-shielded Ball Bearing

Operation Conditions

- Fluid Temperature: 0 to 50°C (122°F)

Material

No.	Component	Material
1	Cable	H07RN-F
2	Handle	AISI 304+Nylon
3	Pump Cover	AISI 304
4	Motor Cover	AISI 304
5	Motor Casing	AISI 304
6	Fixing Ring	Nylon+30GF
7	Pump body	AISI 304
8	Mechanical seal	Sic /Sic / NBR
9	Impeller	AISI 304
10	Key	AISI 304
11	O-RING	NBR
12	Oil Seal	NBR
13	Shaft	AISI 304
14	V-type Axial Oil Seal	NBR
15	Suction flange	AISI 304
		Thermoplastic polyurethane TPU
16	Strainer	AISI 304

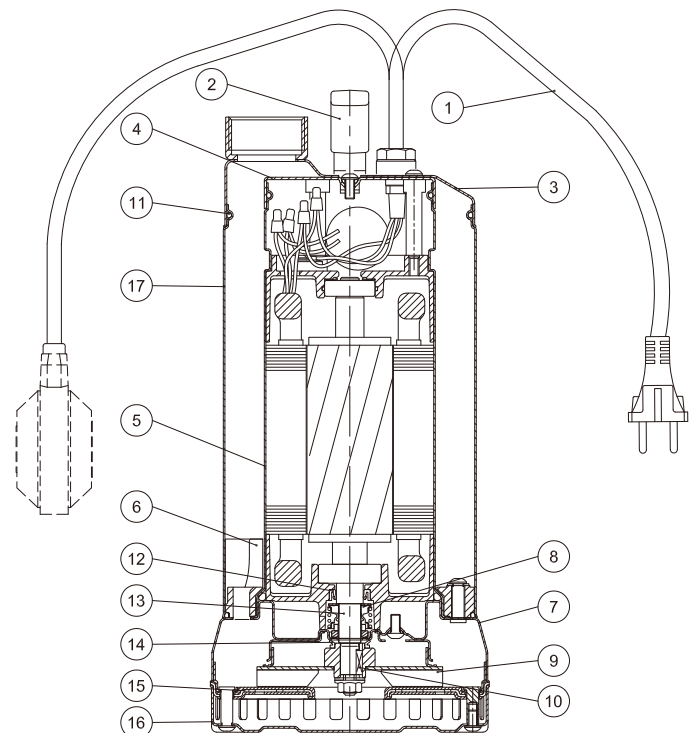

Performance Curves

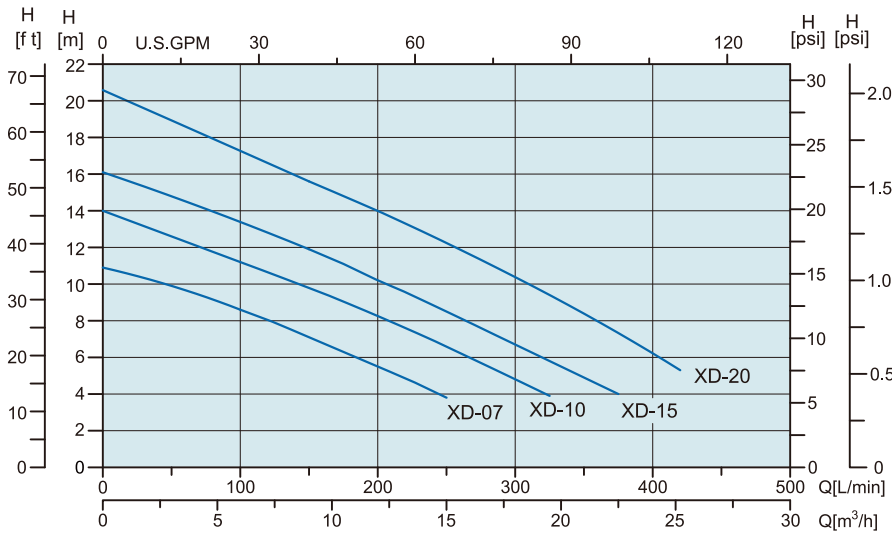

Technical Data

Single Phase

Model	Power		Current [A]	Capacitort	Head		Flow		Discharge
	HP	Kw			Rated (M)	Max (M)	Rated (L/min)	Max (L/min)	
XD 07-M-40	0.75	0.55	3.5-3.2	15uF/450V	8.6	10.9	100	250	1 1/2"
XD 07-MA-40									
XD 10-M-40	1.0	0.75	5.5-5.0	22uF/450V	11.2	14.0	100	325	1 1/2"
XD 10-MA-40									
XD 15-M-40	1.5	1.1	7.0-6.4	30uF/450V	11.9	16.1	150	375	1 1/2"
XD 15-MA-40									

Model	Power		Current [A]		Head		Flow		Discharge
	HP	Kw	220-240V	380-415V	Rated (M)	Max (M)	Rated (L/min)	Max (L/min)	
XD 07-T-40	0.75	0.55	2.6-2.4	1.5-1.3	8.6	10.9	100	250	1 1/2"
XD 10-T-40	1.0	0.75	4.1-3.8	2.4-2.2	11.2	14.0	100	325	1 1/2"
XD 15-T-40	1.5	1.1	4.3-4.0	2.5-2.3	11.9	16.1	150	375	1 1/2"
XD 20-T-40	2.0	1.5	6.6-6.0	3.8-3.5	15.3	20.6	150	420	1 1/2"

Dimensions

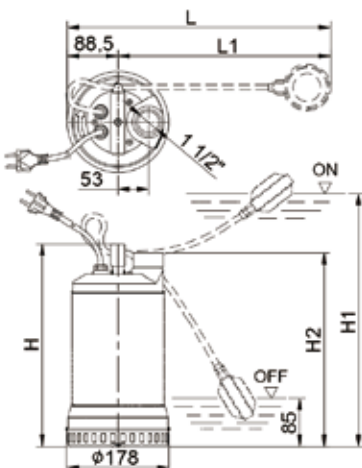

Model	Discharge[mm]					Solid Passage [mm]	Cable		N.W. [kg]
	H	H1	H2	L	L1		H07 RN-F	M	
XD 07-M-40	357	437	341	459	370	8	3G1.0mm ²	10	11.0
XD 07-MA-40	357	437	341	459	370	8	3G1.0mm ²	10	11.5
XD 10-M-40	407	497	391	514	425	8	3G1.0mm ²	10	14.0
XD 10-MA-40	407	497	391	514	425	8	3G1.0mm ²	10	14.5
XD 15-M-40	407	497	391	514	425	8	3G1.5mm ²	10	16.0
XD 15-MA-40	407	497	391	514	425	8	3G1.5mm ²	10	16.5
XD 07-T-40	357	-	341	-	-	8	4G1.0mm ²	10	11.0
XD 10-T-40	357	-	341	-	-	8	4G1.0mm ²	10	12.0
XD 15-T-40	407	-	391	-	-	8	4G1.0mm ²	10	14.0
XD 20-T-40	407	-	391	-	-	8	4G1.5mm ²	10	16.0



Model code

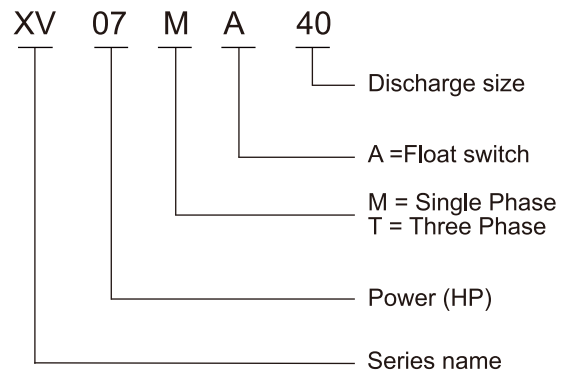

Applications

- Basement water removal
- Waste water drainage
- Water transfer
- Sump/effluent handling
- Dewatering
- Fish pond & fountain circulation
- Factory waste water handling

Motor Data

- Motor Type : 2 POLE , dry type
- Frequency : 50Hz
- Nominal Speed : 2850 rpm
- Insulation Class : F class (155°C)
- Enclosure Protection Class : IP 68
- Protection Device :
Thermal Protector (Single phase)

Pump Data

- Impeller : Open Impeller
- Shaft Seal / Mechanical :
Double Seals
- Bearing :
Double-shielded Ball Bearing

Operation Conditions

- Fluid Temperature: 0 to 35°C (95°F)

Material

No.	Component	Material
1	Cable	H07RN-F
2	Handle	AISI 304+Nylon
3	Motor Cover	AISI 304
4	Motor Casing	AISI 304
5	Fixing Ring	AISI 304
6	Pump Casing	AISI 304
7	Mechanical seal	Sic /Sic / NBR
8	Impeller	AISI 304
9	Key	AISI 304
10	Support Foot	AISI 304
11	Oil Seal	NBR
12	Shaft	AISI 304
13	V-type Axial Oil Seal	NBR
14	Suction flange	AISI 304

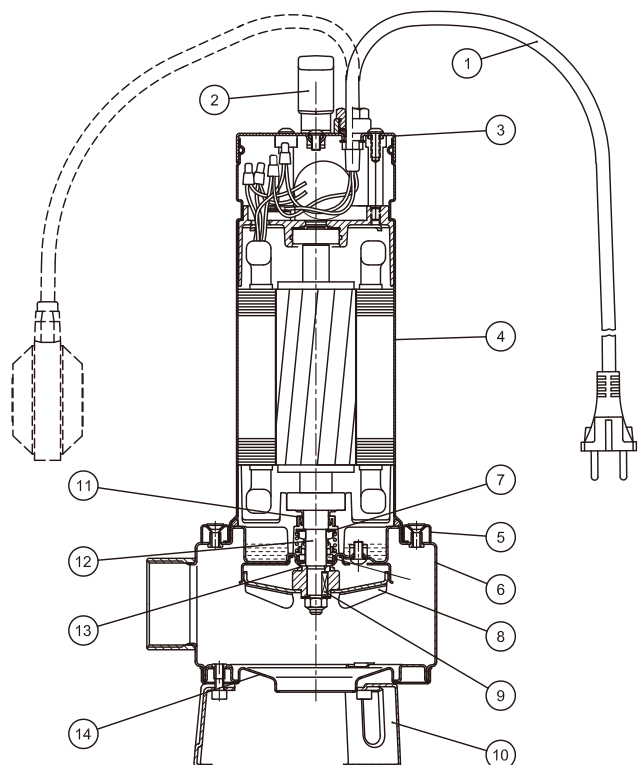

Performance Curves

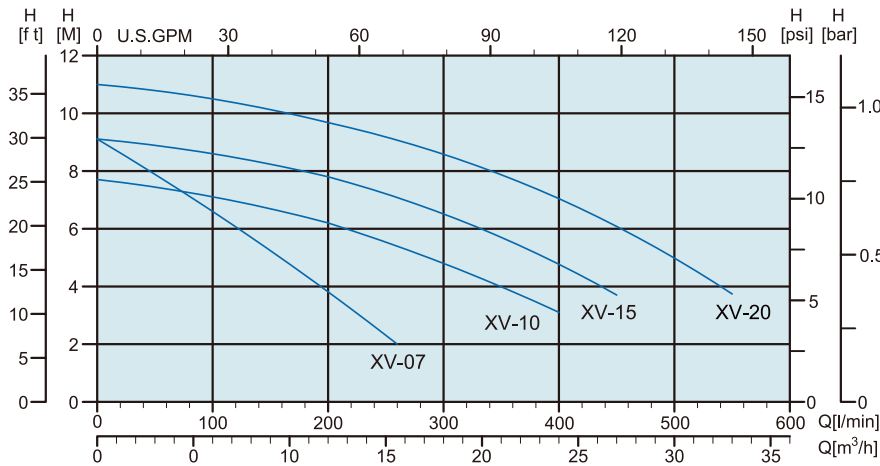

Technical Data

Single Phase

Model	Power		Current [A]	Capacitor	Head		Flow		Discharge
	HP	Kw	220-240V	UF / V	Rated (M)	Max (M)	Rated (L/min)	Max (L/min)	
XV 07-M-40	0.75	0.55	4.1-3.6	15uF/450V	7.1	9.1	80	260	1 1/2"
XV 07-MA-40									
XV 10-M-50	1.0	0.75	5.5-5.1	22uF/450V	7.1	7.7	100	400	2"
XV 10-MA-50									
XV 15-M-50	1.5	1.1	6.8-6.2	30uF/450V	8.6	9.1	100	450	2"
XV 15-MA-50									

A = Auto Float Switch

Three Phase

Model	Power		Current [A]		Head		Flow		Discharge
	HP	Kw	220-240V	380-415V	Rated (M)	Max (M)	Rated (L/min)	Max (L/min)	
XV 07-T-40	0.75	0.55	3.1-2.9	1.8-1.6	7.1	9.1	80	260	1 1/2"
XV 10-T-50	1.0	0.75	4.5-4.1	2.6-2.4	7.1	7.7	100	400	2"
XV 15-T-50	1.5	1.1	5.2-4.8	3.0-2.7	8.6	9.1	100	150	2"
XV 20-T-50	2.0	1.5	6.4-5.9	3.7-3.4	10.2	11.0	150	550	2"

Dimensions

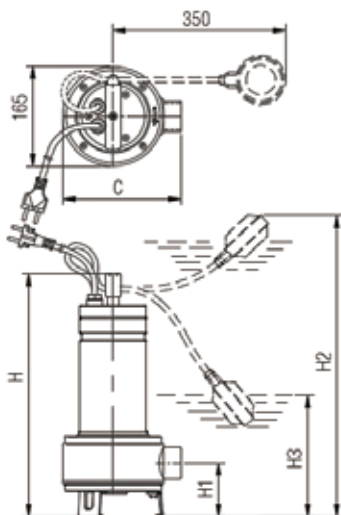

Model	Discharge[mm]					Solid Passage [mm]	Cable		N.W. [kg]
	H	H1	H2	H3	C		H07 RN-F	M	
XV 07-M-40	403	88.0	483	185	193	35	3G1.0mm²	5	9.0
XV 07-MA-40	403	88.0	483	185	193	50	3G1.0mm²	5	10.0
XV 10-M-50	486	111.5	566	268	198	50	3G1.0mm²	10	14.0
XV 10-MA-50	486	111.5	566	268	198	50	3G1.0mm²	10	14.5
XV 15-M-50	486	111.5	566	268	198	50	3G1.5mm²	10	16.0
XV 15-MA-50	486	111.5	566	268	198	50	3G1.5mm²	10	16.5
XV 07-T-50	403	88.0	-	-	193	35	4G1.0mm²	5	11.0
XV 10-T-50	436	111.5	-	-	198	50	4G1.0mm²	10	12.0
XV 15-T-50	486	111.5	-	-	198	50	4G1.0mm²	10	14.0
XV 20-T-50	486	111.5	-	-	198	50	4G1.5mm²	10	16.0



Model Code

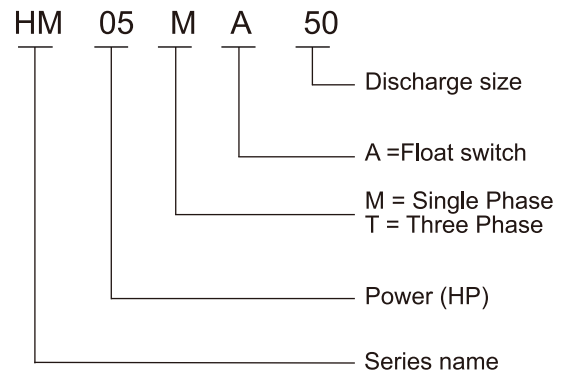

Applications

- Basement water removal
- Waste water drainage
- Water transfer
- Sump/effluent handling
- Dewatering
- Fish pond & fountain circulation
- Factory waste water handling

Motor Data

- Motor Type : 2 POLE , dry type
- Frequency : 50Hz
- Nominal Speed : 2850 rpm
- Insulation Class : F class (155°C)
- Enclosure Protection Class : IP 68
- Protection Device :
Thermal Protector (Single phase)
Overload Protector(Three phase)

Pump Data

- Impeller : Open Impeller
- Shaft Seal / Mechanical :
Double Seals
- Bearing :
Double-shielded Ball Bearing

Operation Conditions

- Fluid Temperature: 0 to 40°C (104°F)

Material

No.	Component	Material
1	Cable	H07RN-F
2	Handle	Nylon6+30GF
3	Motor cover	ADC-12
4	Bearing cap	SECC
5	Motor frame	ADC-12
6	M.Seal Bracket	FC200
7	Cable Base	Nylon6+30GF
8	Motor Shaft	AISI410
9	Mechanical seal	CA / CE, SIC/SIC
10	Oil Seal	NBR70
11	Impeller	TPU
12	Pump casing	FC200
13	Flange	FC200

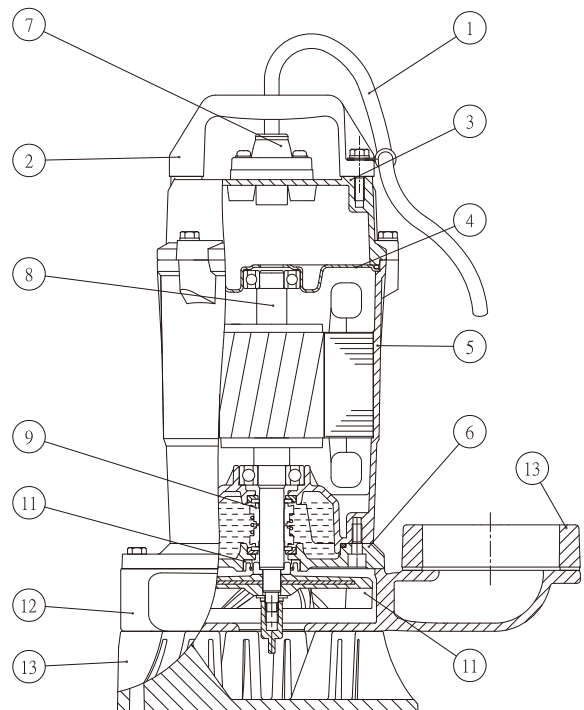

Submersible Drainage Pumps

50Hz

Performance Curves

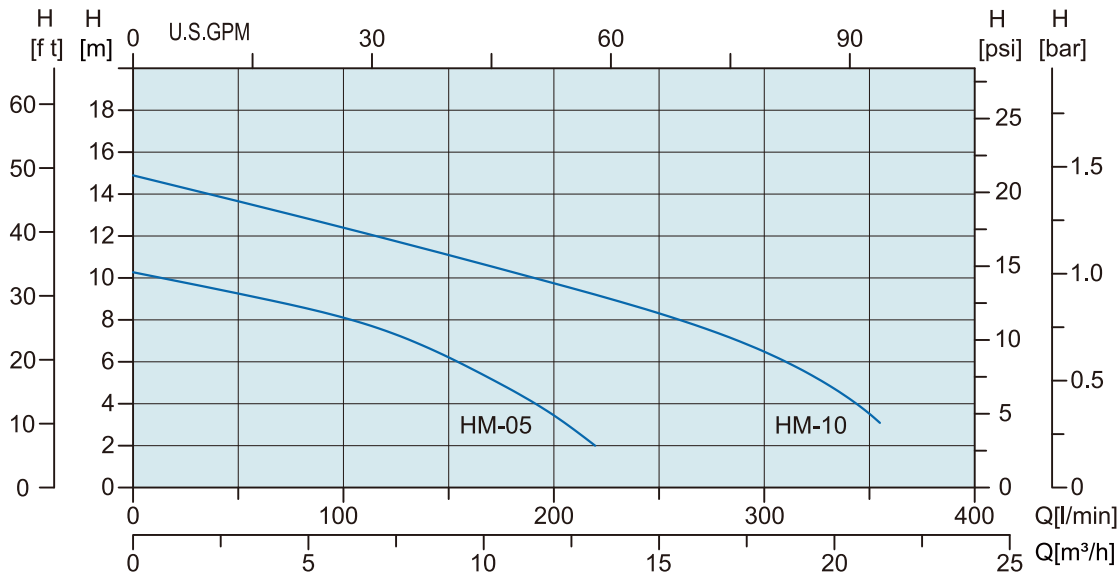

Technical Data

Single Phase

Model	Power		Current [A]	Capacitort	Head		Flow		Discharge
	HP	Kw	220-240V	UF / V	Rated (M)	Max (M)	Rated (L/min)	Max (L/min)	inch
HM 05-M-50	0.5	0.37	2.7-2.5	12uF/450V	7.0	11.0	140	225	2"
HM 05-MA-50									
HM 10-M-50	1.0	0.75	5.8-5.4	20uF/450V	10.0	18.6	230	335	2"
HM 10-MA-50									
HM 10-M-80	1.0	0.75	5.8-5.4	20uF/450V	10.0	18.6	230	335	3"
HM 10-MA-80									

Three Phase

Model	Power		Current [A]		Head		Flow		Discharge
	HP	Kw	220-240V	380-415V	Rated (M)	Max (M)	Rated (L/min)	Max (L/min)	inch
HM 05-T-50	0.5	0.37	2.1-2.0	1.3-1.2	7.0	11.0	140	225	2"
HM 10-T-50	1.0	0.75	3.6-3.4	2.1-1.9	10.0	18.6	230	335	2"
HM 10-T-80	1.0	0.75	3.6-3.4	2.1-1.9	10.0	18.6	230	335	3"

Dimensions

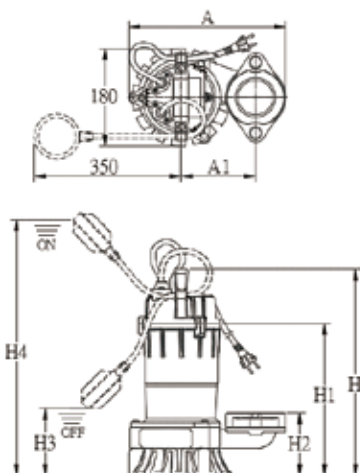

Model	Discharge[mm]							Solid Passage [mm]	Cable		N.W. [kg]
	H	H1	H2	H3	H4	A	A1		M	H07 RN-F	
HM 05-M-50	365	264	110	115	535	254	120	10	10	3G1.0mm ²	12.9
HM 05-MA-50	365	264	110	115	535	254	120	10	10	3G1.0mm ²	13.4
HM 10-M-50	380	279	116	130	550	285	135	10	10	3G1.0mm ²	15.1
HM 10-MA-50	380	279	116	130	550	285	135	10	10	3G1.0mm ²	15.6
HM 10-M-80	380	279	116	130	550	285	135	10	10	3G1.0mm ²	15.1
HM 10-MA-80	380	279	116	130	550	285	135	10	10	3G1.0mm ²	15.6
HM 05-T-50	365	264	110	-	-	254	120	10	10	4G1.0mm ²	11.9
HM 10-T-50	380	279	116	-	-	285	135	10	10	4G1.0mm ²	14.1
HM 10-T-80	380	279	116	-	-	285	135	10	10	4G1.0mm ²	14.1



Model Code

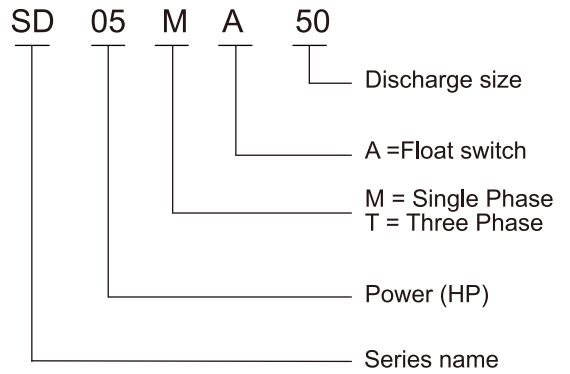

Applications

- Basement water removal
- Waste water drainage
- Water transfer
- Sump/effluent handling
- Dewatering
- Fish pond & fountain circulation
- Factory waste water handling

Motor Data

- Motor Type : 2 POLE , dry type
- Frequency : 50Hz
- Nominal Speed : 2850 rpm
- Insulation Class : F class (155°C)
- Enclosure Protection Class : IP 68
- Protection Device : Thermal Protector (Single phase)

Pump Data

- Impeller : Open Impeller
- Shaft Seal / Mechanical : Double Seals
- Bearing : Double-shielded Ball Bearing

Operation Conditions

- Fluid Temperature: 0 to 50°C (122°F)

Material

NO.	Component	Material
1	Cable	H07RN-F
2	Handle	Nylon6+30GF(0.5~1.0HP) AISI304+NBR(2.0~5.0HP) SS41(7.5HP)
3	Motor cover	FC200
4	Bearing cap	FC200
5	Motor frame	AISI 304
6	Bearing Bracket	FC200
7	M.Seal Bracket	FC200
8	Cable Base	Nylon6+30GF
9	Motor Shaft	AISI410
10	Mechanical seal	CA/CE,SIC/SIC
11	Oil Seal	NBR 70
12	Impeller	FC25
13	Pump Casing	FC200
14	Flange	FC200
15	Strainer	AISI 304

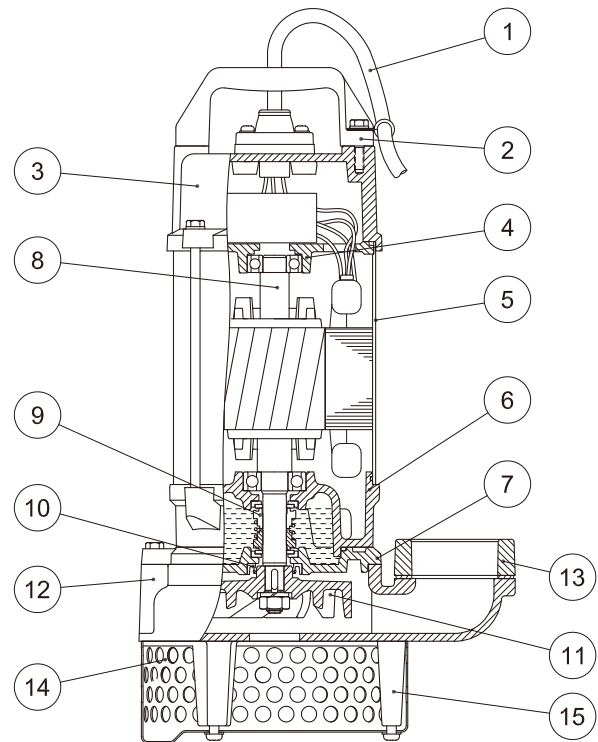

Performance Curves

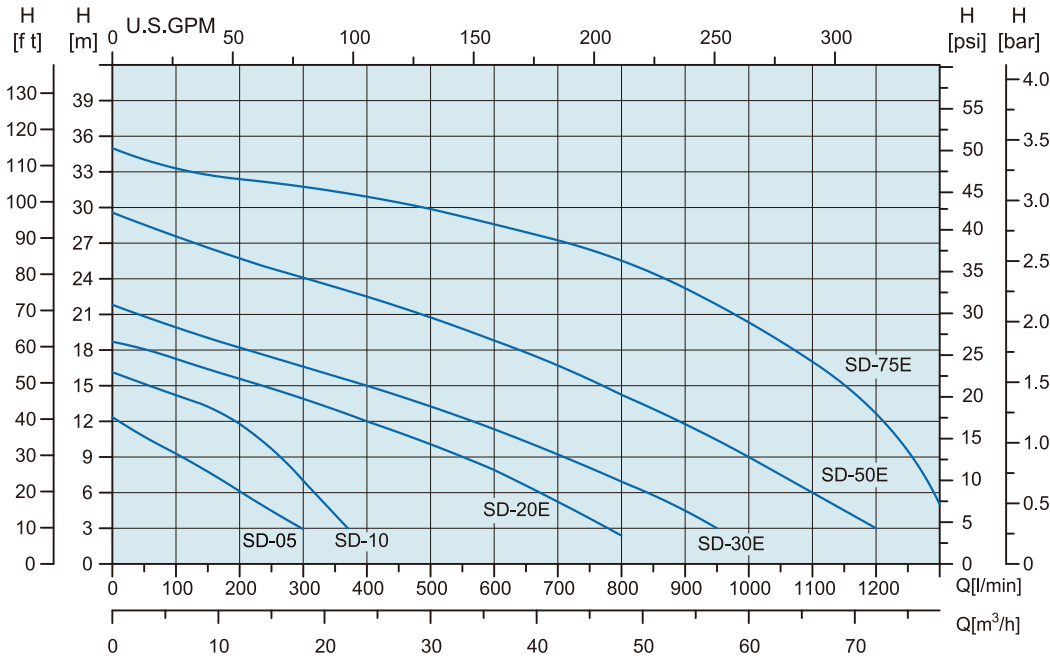

Technical Data

Single Phase

Model	Power		Current [A]	Capacitor	Head		Flow		Discharge
	HP	Kw			Rated (M)	Max (M)	Rated (L/min)	Max (L/min)	
SD 05-M-50	0.5	0.37	3.6-3.4	12uF/450V	7.5	12	170	300	2"
SD 05-MA-50									
SD 10-M-50	1.0	0.75	5.2-4.8	20uF/450V	11	16.5	220	370	2"
SD 10-MA-50									
SD 20E-M-50	2.0	1.5	10.0-9.2	40uF/450V	10.3	18.9	525	800	2"
SD 20E-MA-50									
SD 20E-M-80	2.0	1.5	10.0-9.2	40uF/450V	10.3	18.9	525	800	3"
SD 20E-MA-80									

A = Auto Float Switch

Three Phase

Model	Power		Current [A]		Head		Flow		Discharge
	HP	Kw	220-240V	380-415V	Rated (M)	Max (M)	Rated (L/min)	Max (L/min)	
SD 05-T-50	0.5	0.37	2.5-2.3	1.2-1.1	7.5	12.0	170	300	2"
SD 10-T-50	1.0	0.75	3.5-3.2	2.0-1.8	11.0	16.5	220	370	2"
SD 20E-T-50	2.0	1.5	6.5-6.0	3.7-3.5	10.3	18.9	525	800	2"
SD 20E-T-80	2.0	1.5	6.5-6.0	3.7-3.5	10.3	18.9	525	800	3"
SD 30E-T-50	3.0	2.2	8.7-8.0	5.0-4.6	13.5	22.0	500	965	2"
SD 30E-T-80	3.0	2.2	8.7-8.0	5.0-4.6	13.5	22.0	500	965	3"
SD 50E-T-80	5.0	3.7	14.2-13.0	8.2-7.6	20.0	29.6	485	1200	3"
SD 50E-T-100	5.0	3.7	14.2-13.0	8.2-7.6	20.0	29.6	485	1200	4"
SD 75E-T-80	7.5	5.5	21.0-19.3	12.0-11.0	26.0	35.0	780	1300	3"
SD 75E-T-100	7.5	5.5	21.0-19.3	12.0-11.0	26.0	35.0	780	1300	4"

Dimensions

Model	Discharge[mm]								Solid Passage [mm]	Cable-10M H07 RN-F	N.W. [kg]
	H	H1	H2	H3	A	B	C	D			
SD 05-M-50	411	356	114	130	240	201	–	173	10	3G1.0mm ²	16.0
SD 05-MA-50	411	356	114	130	240	201	–	173	10	3G1.0mm ²	16.5
SD 10-M-50	431	376	114	130	240	201	–	173	10	3G1.0mm ²	18.0
SD 10-MA-50	431	376	114	130	240	201	–	173	10	3G1.0mm ²	18.5
SD 20E-M-50	546	480	133	227	398	343	253	220	10	3G1.5mm ²	42.5
SD 20E-MA-50	546	480	133	227	398	343	253	220	10	3G1.5mm ²	43.0
SD 20E-M-80	546	480	133	227	398	343	253	220	10	3G1.5mm ²	42.5
SD 20E-MA-80	546	480	133	227	398	343	253	220	10	3G1.5mm ²	43.0
SD 05-T-50	411	356	114	130	240	201	–	173	10	4G1.0mm ²	15.0
SD 10-T-50	431	376	114	130	240	201	–	173	10	4G1.0mm ²	17.0
SD 20E-T-50	506	441	133	227	398	343	255	220	10	4G1.5mm ²	36.0
SD 20E-T-80	506	441	133	227	398	343	255	220	10	4G1.5mm ²	36.0
SD 30E-T-50	506	441	133	227	398	343	255	220	10	4G1.5mm ²	38.5
SD 30E-T-80	506	441	133	227	398	343	255	220	10	4G1.5mm ²	38.5
SD 50E-T-80	526	461	133	265	430	337	255	220	10	4G2.5mm ²	45.0
SD 50E-T-100	526	461	133	265	430	337	255	220	10	4G2.5mm ²	45.0
SD 75E-T-80	658	553	133	265	474	380	294	230	10	4G2.5mm ²	61.0
SD 75E-T-100	658	553	133	265	474	380	294	230	10	4G2.5mm ²	61.0

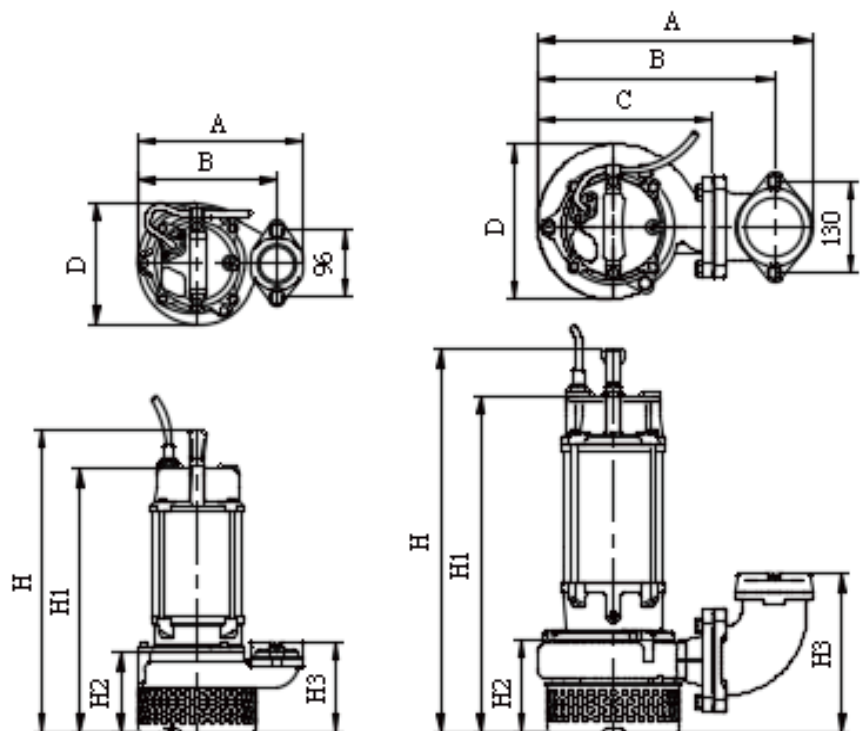



Model Code

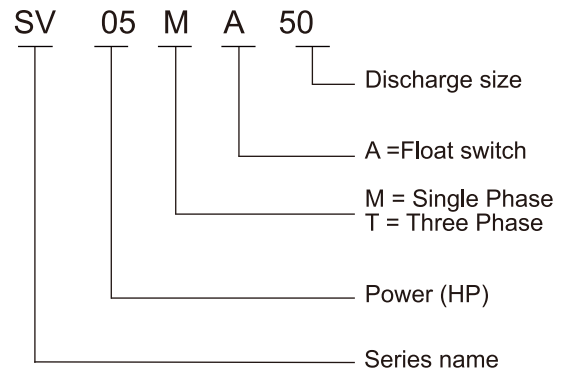

Applications

- Basement water removal
- Waste water drainage
- Water transfer
- Sump/effluent handling
- Dewatering
- Fish pond & fountain circulation
- Factory waste water handling

Motor Data

- Motor Type : 2 POLE , dry type
- Frequency : 50Hz
- Nominal Speed : 2850 rpm
- Insulation Class : F class (155°C)
- Enclosure Protection Class : IP 68
- Protection Device :
Thermal Protector (Single phase)
Overload Protector(Three phase)

Pump Data

- Impeller : Open Impeller
- Shaft Seal / Mechanical :
Double Seals
- Bearing :
Double-shielded Ball Bearing

Operation Conditions

- Fluid Temperature: 0 to 40°C (104°F)

Material

NO.	Component	Material
1	Cable	H07RN-F
2	Handle	Nylon6+30GF(0.5~1.0HP) AISI304+NBR(2.0~5.0HP) SS41(7.5HP)
3	Motor cover	FC200
4	Bearing cap	FC200
5	Motor frame	AISI 304
6	Bearing Bracket	FC200
7	M.Seal Bracket	FC200
8	Motor Shaft	AISI410
9	Mechanical seal	CA / CE, SIC/SIC
10	Oil Seal	NBR70
11	Impeller	FC250
12	Pump casing	FC200
13	Flange	FC200

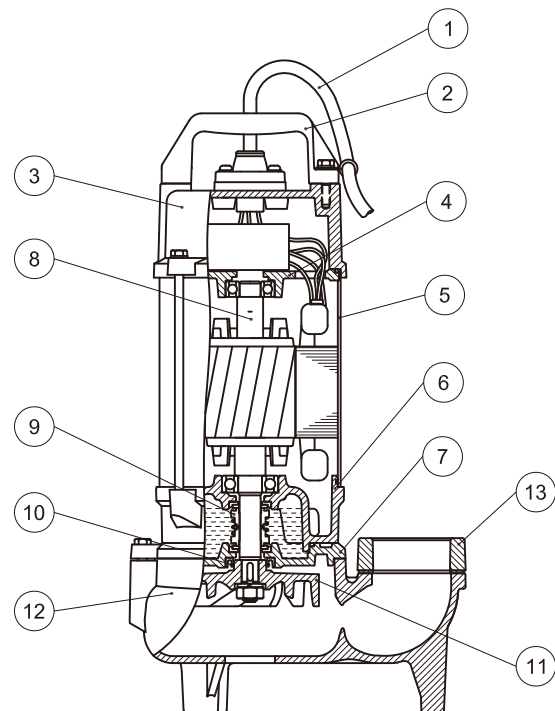

Submersible Vortex Sewage Pumps

50Hz

Performance Curves

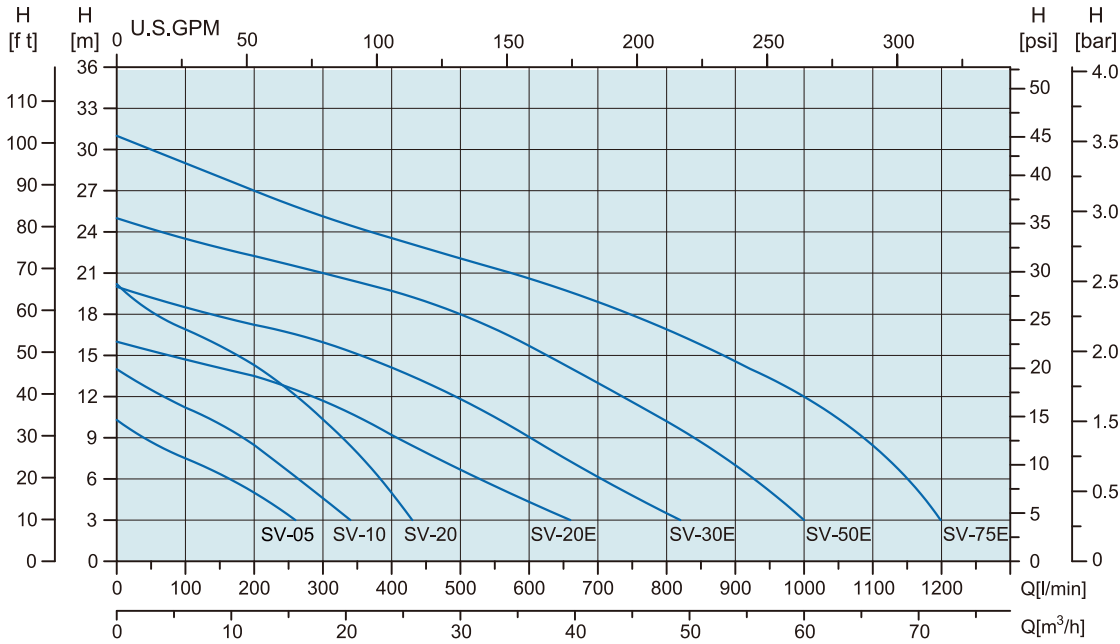

Technical Data

Single Phase

Model	Power		Current [A]	Capacitor	Head		Flow		Discharge inch
	HP	Kw	220-240V	UF / V	Rated (M)	Max (M)	Rated (L/min)	Max (L/min)	
SV 05-M-50	0.5	0.37	3.6-3.4	12uF/450V	6.0	10.0	150	280	2"
SV 05-MA-50									
SV 10-M-50	1.0	0.75	5.2-4.8	20uF/450V	8.0	13.5	200	350	2"
SV 10-MA-50									
SV 20-M-50	2.0	1.5	10.0-9.2	40uF/450V	14.0	20.2	200	415	2"
SV 20-MA-50									
SV 20E-M-50	2.0	1.5	10.0-9.2	40uF/450V	8.5	16.0	400	680	2"
SV 20E-MA-50									
SV 20E-M-80	2.0	1.5	10.0-9.2	40uF/450V	8.5	16.0	400	680	3"
SV 20E-MA-80									

A = Auto Float Switch

Three Phase

Model	Power		Current [A]		Head		Flow		Discharge inch
	HP	Kw	220-240V	380-415V	Rated (M)	Max (M)	Rated (L/min)	Max (L/min)	
SV 05-T-50	0.5	0.37	2.5-2.3	1.5-1.3	6.0	10.0	150	280	2"
SV 10-T-50	1.0	0.75	3.5-3.2	2.0-1.8	8.0	13.5	200	350	2"
SV 20-T-50	2.0	1.5	6.5-6.0	3.7-3.5	14.0	20.2	200	415	2"
SV 20E-T-50	2.0	1.5	6.5-6.0	3.7-3.5	8.5	16.0	400	680	2"
SV 20E-T-80	2.0	1.5	6.5-6.0	3.7-3.5	8.5	16.0	400	680	3"
SV 30E-T-50	3.0	2.2	8.7-8.0	5.0-4.6	12.5	19.5	400	810	2"
SV 30E-T-80	3.0	2.2	8.7-8.0	5.0-4.6	12.5	19.5	400	810	3"
SV 50E-T-80	5.0	3.7	14.2-13.0	8.2-7.6	16.5	24.9	500	1010	3"
SV 50E-T-100	5.0	3.7	14.2-13.0	8.2-7.6	16.5	24.9	500	1010	4"
SV 75E-T-80	7.5	5.5	21.0-19.3	12.0-11.0	20.0	31.0	640	1200	3"
SV 75E-T-100	7.5	5.5	21.0-19.3	12.0-11.0	20.0	31.0	640	1200	4"

Dimensions

Model	Discharge[mm]								Solid Passage [mm]	Cable-10M H07 RN-F	N.W. [kg]
	H	H1	H2	H3	A	B	C	D			
SV 05-M-50	406	352	110	124	240	201	–	153	35	3G1.0mm ²	17.0
SV 05-MA-50	406	352	110	124	240	201	–	153	35	3G1.0mm ²	17.5
SV 10-M-50	406	372	110	124	240	201	–	153	35	3G1.0mm ²	18.5
SV 10-MA-50	406	372	110	124	240	201	–	153	35	3G1.0mm ²	19.0
SV 20-M-50	520	454	100	112	279	240	–	186	35	3G1.5mm ²	30.0
SV 20-MA-50	520	454	100	112	279	240	–	186	35	3G1.5mm ²	30.5
SV 20E-M-50	526	496	141	205	395	340	252	186	50	3G1.5mm ²	37.0
SV 20E-MA-50	526	496	141	205	395	340	252	186	50	3G1.5mm ²	37.5
SV 20E-M-80	526	496	141	205	395	340	252	186	50	3G1.5mm ²	37.0
SV 20E-MA-80	526	496	141	205	395	340	252	186	50	3G1.5mm ²	37.5
SV 05-T-50	406	352	110	124	240	201	–	153	35	4G1.0mm ²	16.0
SV 10-T-50	426	372	110	124	240	201	–	153	35	4G1.0mm ²	17.5
SV 20-T-50	480	414	100	112	279	240	–	186	35	4G1.5mm ²	27.0
SV 20E-T-50	522	456	141	205	395	340	255	186	50	4G1.5mm ²	34.0
SV 20E-T-80	522	456	141	205	395	340	255	186	50	4G1.5mm ²	34.0
SV 30E-T-50	522	456	141	205	395	340	255	186	50	4G1.5mm ²	36.5
SV 30E-T-80	522	456	141	205	395	340	255	186	50	4G1.5mm ²	36.5
SV 50E-T-80	542	476	141	240	428	335	255	186	50	4G2.5mm ²	40.5
SV 50E-T-100	542	476	141	240	428	335	255	186	50	4G2.5mm ²	40.5
SV 75E-T-80	680	579	158	253	472	380	294	227	50	4G2.5mm ²	61.0
SV 75E-T-100	680	579	158	253	472	380	294	227	50	4G2.5mm ²	61.0

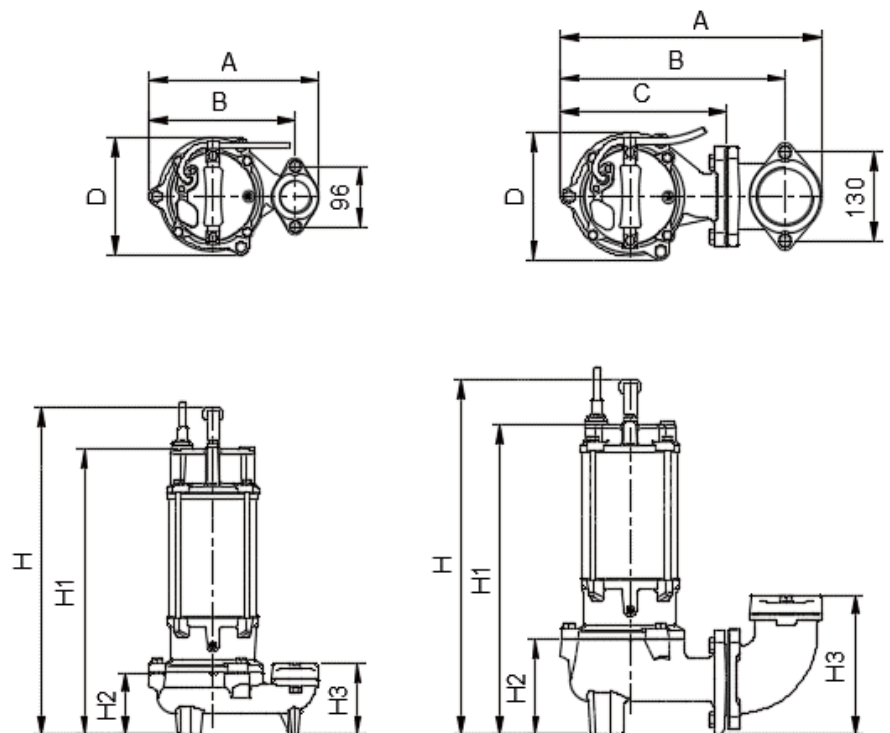



Model Code

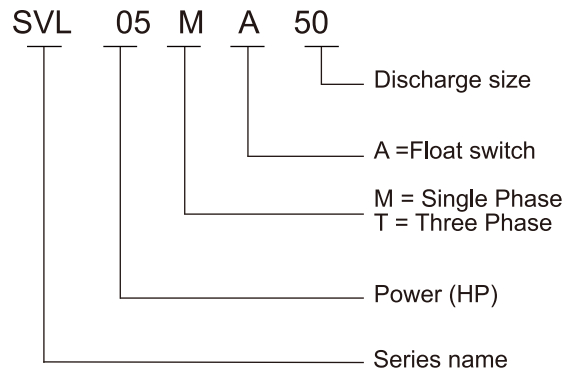

Applications

- Basement water removal
- Waste water drainage
- Water transfer
- Sump/effluent handling
- Dewatering
- Fish pond & fountain circulation
- Factory waste water handling

Motor Data

- Motor Type : 2 POLE , dry type
- Frequency : 50Hz
- Nominal Speed : 2850 rpm
- Insulation Class : F class (155°C)
- Enclosure Protection Class : IP 68
- Protection Device :
Thermal Protector (Single phase)
Overload Protector(Three phase)

Pump Data

- Impeller : Open Impeller
- Shaft Seal / Mechanical :
Double Seals
- Bearing :
Double-shielded Ball Bearing

Operation Conditions

- Fluid Temperature: 0 to 40°C (104°F)

Material

NO.	Component	Material
1	Cable	H07RN-F
2	Handle	Nylon6+30GF
3	Motor cover	FC200
4	Bearing cap	FC200
5	Motor frame	AISI 304
6	Bearing Bracket	FC200
7	M.Seal Bracket	FC200
8	Motor Shaft	AISI410
9	Mechanical seal	CA / CE, SIC/SIC
10	Oil Seal	NBR70
11	Impeller	FC250
12	Pump casing	FC200
13	Flange	FC200

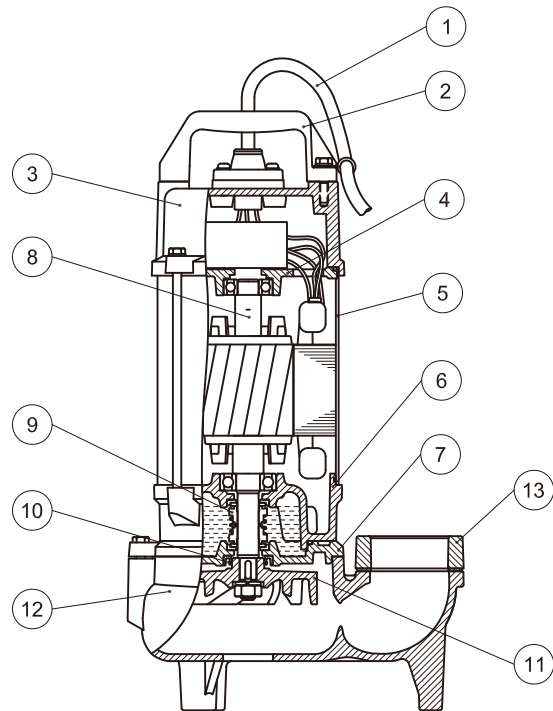

Performance Curves

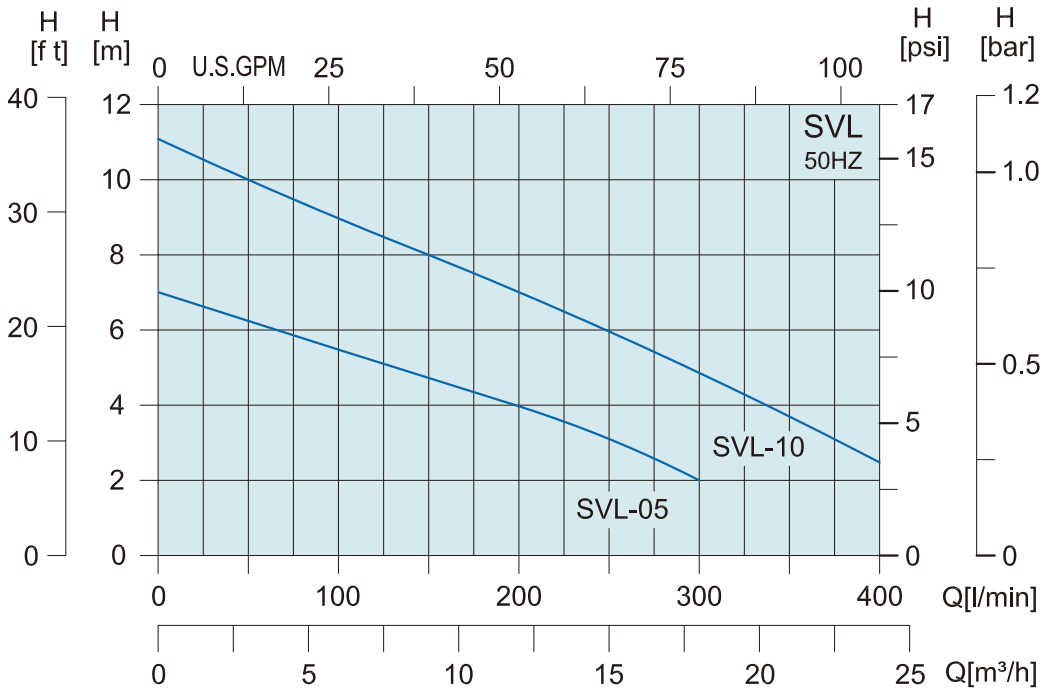

Technical Data

Single Phase

Model	Power		Current [A]	Capacitor	Head		Flow		Discharge
	HP	Kw			Rated (M)	Max (M)	Rated (L/min)	Max (L/min)	
SVL 05-M-50	0.5	0.37	3.6-3.4	12uF/450V	4.0	7.0	200	300	2"
SVL 05-MA-50									
SVL 10-M-50	1.0	0.75	5.2-4.8	20uF/450V	6.0	11.0	250	400	2"
SVL 10-MA-50									
SVL 05-M-80	0.5	0.37	3.6-3.4	12uF/450V	4.0	7.0	200	300	3"
SVL 05-MA-80									
SVL 10-M-80	1.0	0.75	3.6-3.4	20uF/450V	6.0	11.0	250	400	3"
SVL 10-MA-80									

A = Auto Float Switch

Three Phase

Model	Power		Current [A]		Head		Flow		Discharge
	HP	Kw	220-240V	380-415V	Rated (M)	Max (M)	Rated (L/min)	Max (L/min)	
SVL 05-T-50	0.5	0.37	2.5-2.3	1.5-1.3	4.0	7.0	200	300	2"
SVL 10-T-50	1.0	0.75	3.5-3.2	2.0-1.8	6.0	11.0	250	350	2"
SVL 05-T-80	0.5	0.37	2.5-2.3	1.5-1.3	4.0	7.0	200	300	3"
SVL 10-T-80	1.0	0.75	3.5-3.2	2.0-1.8	6.0	11.0	250	400	3"

Dimensions

Model	Discharge[mm]								Solid Passage [mm]	Cable-10M	N.W.
	H	H1	H2	H3	A	B	C	D		H07 RN-F	[kg]
SVL 05-M-50	437	383	141	143	247	208	-	166	50	3G1.0mm ²	19.0
SVL 05-MA-50	437	383	141	143	247	208	-	166	50	3G1.0mm ²	19.5
SVL 10-M-50	457	403	141	143	247	208	-	166	50	3G1.0mm ²	20.7
SVL 10-MA-50	457	403	141	143	247	208	-	166	50	3G1.0mm ²	21.2
SVL 05-M-80	437	383	141	143	283	227	-	166	50	3G1.5mm ²	19.0
SVL 05-MA-80	437	383	141	143	283	227	-	166	50	3G1.5mm ²	19.5
SVL 10-M-80	457	403	141	143	283	227	-	166	50	3G1.5mm ²	20.7
SVL 10-MA-80	457	403	141	143	283	227	-	166	50	3G1.5mm ²	21.2
SVL 05-T-50	437	383	141	143	247	208	-	166	50	3G1.5mm ²	18.0
SVL 10-T-50	457	403	141	143	247	208	-	166	50	3G1.5mm ²	19.5
SVL 05-T-80	437	383	141	143	283	227	-	166	50	4G1.0mm ²	18.0
SVL 10-T-80	457	403	141	143	283	227	-	166	50	4G1.0mm ²	19.5

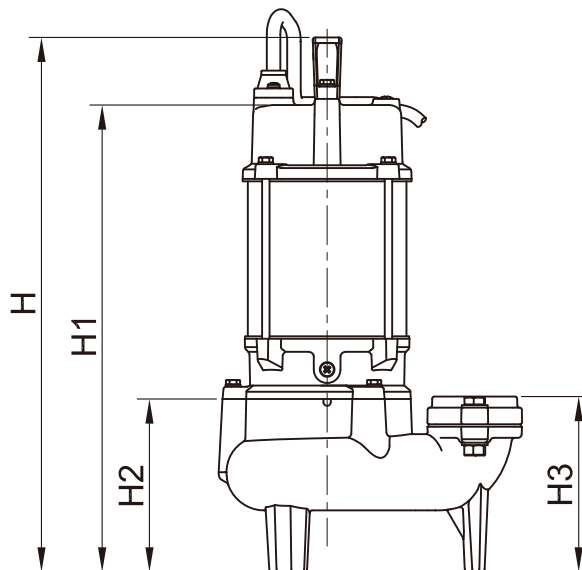
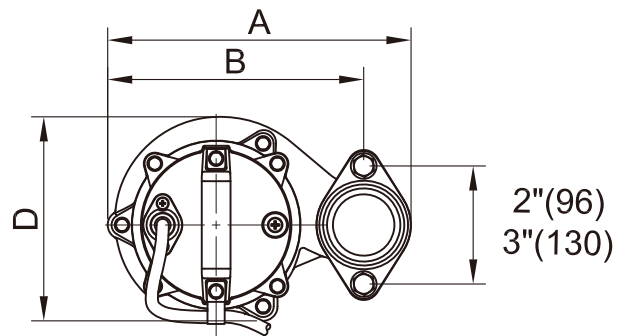



Model Code

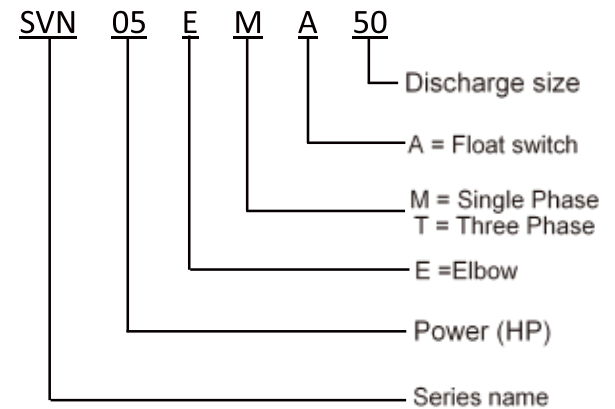

Applications

- Basement water removal
- Waste water drainage
- Water transfer
- Sump/effluent handling
- Dewatering
- Fish pond & fountain circulation
- Factory waste water handling

Motor Data

- Motor Type : 2 POLE , dry type
- Frequency : 50Hz
- Nominal Speed : 2850 rpm
- Insulation Class : F class (155°C)
- Enclosure Protection Class : IP 68
- Protection Device :
Thermal Protector (Single phase)
Overload Protector(Three phase)

Pump Data

- Impeller : Open Impeller
- Shaft Seal / Mechanical :
Double Seals
- Bearing :
Double-shielded Ball Bearing

Operation Conditions

- Fluid Temperature: 0 to 40°C (104°F)

Material

No.	Component	Material
1	Cable	H07RN-F
2	Handle	Nylon6+30GF AISI304+NBR
3	Motor cover	CF8M
4	Bearing cap	FC200
5	Motor frame	AISI 304
6	Bearing Bracket	CF8M
7	M.Seal Bracket	CF8M
8	Motor Shaft	AISI410
9	Mechanical seal	CA / CE, SIC/SIC
10	Oil Seal	VITON70
11	Impeller	CF8M
12	Pump casing	CF8M
13	Flange	CF8M

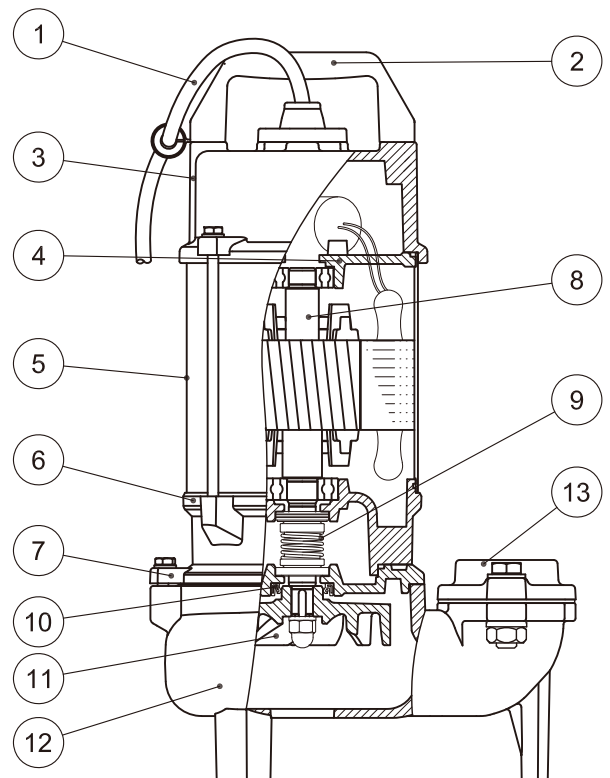

Performance Curves

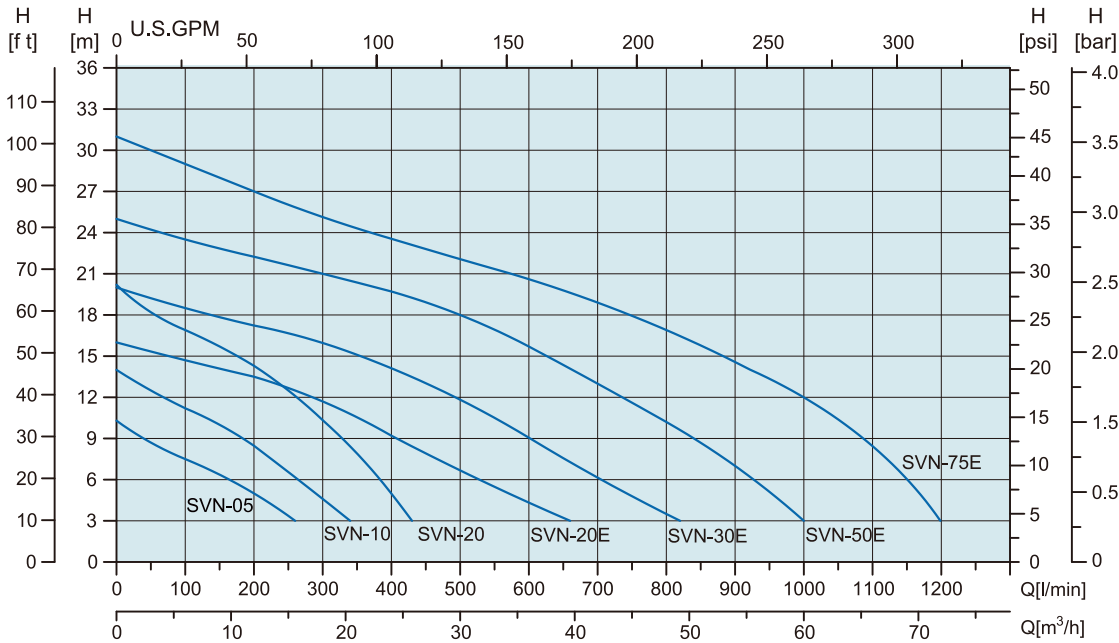

Technical Data

Single Phase

Model	Power		Current [A]	Capacitort	Head		Flow		Discharge
	HP	Kw			Rated (M)	Max (M)	Rated (L/min)	Max (L/min)	
SVN 05-M-50	0.5	0.37	3.6-3.4	12uF/450V	6.0	10.0	150	280	2"
SVN 05-MA-50									
SVN 10-M-50	1.0	0.75	5.2-4.8	20uF/450V	8.0	13.5	200	350	2"
SVN 10-MA-50									
SVN 20-M-50	2.0	1.5	10.0-9.2	40uF/450V	14.0	20.2	200	415	2"
SVN 20-MA-50									
SVN 20E-M-50	2.0	1.5	10.0-9.2	40uF/450V	8.5	16.0	400	680	2"
SVN 20E-MA-50									
SVN 20E-M-80	2.0	1.5	10.0-9.2	40uF/450V	8.5	16.0	400	680	3"
SVN 20E-MA-80									

Three Phase

Model	Power		Current [A]		Head		Flow		Discharge
	HP	Kw	220-240V	380-415V	Rated (M)	Max (M)	Rated (L/min)	Max (L/min)	
SVN 05-T-50	0.5	0.37	2.5-2.3	1.5-1.3	6.0	10.0	150	280	2"
SVN 10-T-50	1.0	0.75	3.5-3.2	2.0-1.8	8.0	13.5	200	350	2"
SVN 20-T-50	2.0	1.5	6.5-6.0	3.7-3.5	14.0	20.2	200	415	2"
SVN 20E-T-50	2.0	1.5	6.5-6.0	3.7-3.5	8.5	16.0	400	680	2"
SVN 20E-T-80	2.0	1.5	6.5-6.0	3.7-3.5	8.5	16.0	400	680	3"
SVN 30E-T-50	3.0	2.2	8.7-8.0	5.0-4.6	12.5	19.5	400	810	2"
SVN 30E-T-80	3.0	2.2	8.7-8.0	5.0-4.6	12.5	19.5	400	810	3"
SVN 50E-T-80	5.0	3.7	14.2-13.0	8.2-7.6	16.5	24.9	500	1010	3"
SVN 50E-T-100	5.0	3.7	14.2-13.0	8.2-7.6	16.5	24.9	500	1010	4"
SVN 75E-T-80	7.5	5.5	19.3-18.5	11.5-10.3	20.0	31.0	640	1200	3"
SVN 75E-T-100	7.5	5.5	19.3-18.5	11.5-10.3	20.0	31.0	640	1200	4"

Dimensions

Model	Discharge[mm]								Solid Passage [mm]	Cable-10M H07 RN-F	N.W. [kg]
	H	H1	H2	H3	A	B	C	D			
SVN 05-M-50	406	352	110	124	240	201	–	153	35	3G1.0mm ²	15.5
SVN 05-MA-50	406	352	110	124	240	201	–	153	35	3G1.0mm ²	16.0
SVN 10-M-50	406	372	110	124	240	201	–	153	35	3G1.0mm ²	17.0
SVN 10-MA-50	406	372	110	124	240	201	–	153	35	3G1.0mm ²	17.5
SVN 20-M-50	520	454	100	112	279	240	–	186	35	3G1.5mm ²	28.0
SVN 20-MA-50	520	454	100	112	279	240	–	186	35	3G1.5mm ²	28.5
SVN 20E-M-50	526	496	141	205	395	340	252	186	50	3G1.5mm ²	34.0
SVN 20E-MA-50	526	496	141	205	395	340	252	186	50	3G1.5mm ²	34.5
SVN 20E-M-80	526	496	141	205	395	340	252	186	50	3G1.5mm ²	34.0
SVN 20E-MA-80	526	496	141	205	395	340	252	186	50	3G1.5mm ²	34.5
SVN 05-T-50	406	352	110	124	240	201	–	153	35	4G1.0mm ²	13.0
SVN 10-T-50	426	372	110	124	240	201	–	153	35	4G1.0mm ²	14.5
SVN 20-T-50	480	414	100	112	279	240	–	186	35	4G1.5mm ²	25.5
SVN 20E-T-50	522	456	141	205	395	340	255	186	50	4G1.5mm ²	32.0
SVN 20E-T-80	522	456	141	205	395	340	255	186	50	4G1.5mm ²	32.0
SVN 30E-T-50	522	456	141	205	395	340	255	186	50	4G1.5mm ²	34.0
SVN 30E-T-80	522	456	141	205	395	340	255	186	50	4G1.5mm ²	34.0
SVN 50E-T-80	542	476	141	240	428	335	255	186	50	4G2.5mm ²	41.0
SVN 50E-T-100	542	476	141	240	428	335	255	186	50	4G2.5mm ²	41.0
SVN 75E-T-80	680	579	158	253	472	380	294	227	50	4G2.5mm ²	57.0
SVN 75E-T-100	680	579	158	253	472	380	294	227	50	4G2.5mm ²	57.0

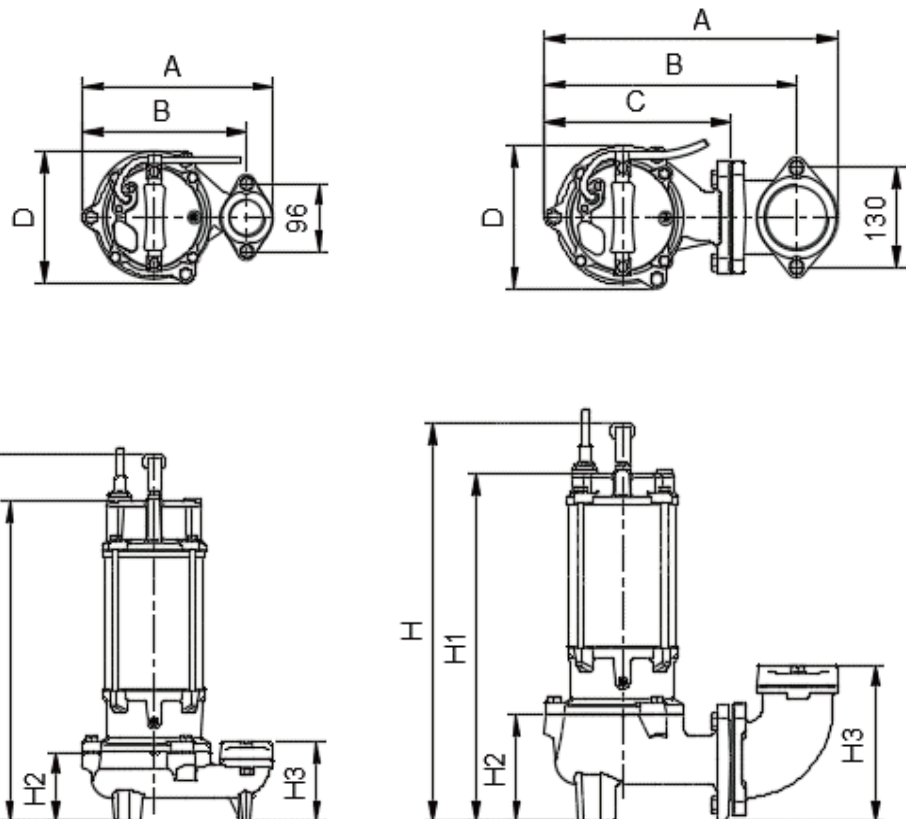

TS-50

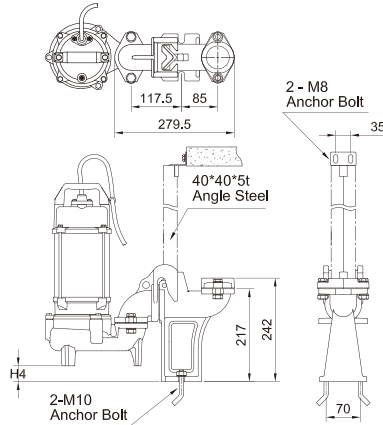

Model	TS-50 Guide Rail	
	DN (mm)	Dimensions H4(mm)
SD-05-50	50	31
SD-10-50	50	31
SV-05-50	50	37
SV-10-50	50	37
SV-20-50	50	45
SVL-05-50	50	15
SVL-10-50	50	15
HM-05-50	50	48

TSL-50/80

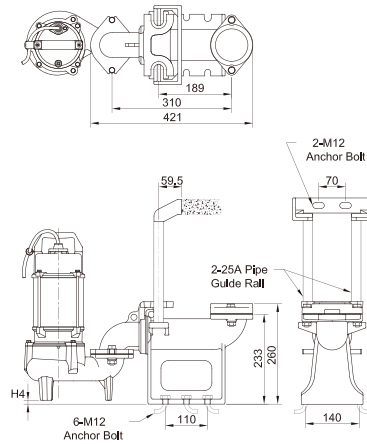

Model	TSL-50/80 Guide Rail	
	DN (mm)	Dimensions H4(mm)
SVL-05-80	80	10
SVL-10-80	80	10
HM-10-50	50	43
HM-10-80	80	43

TM-50/80

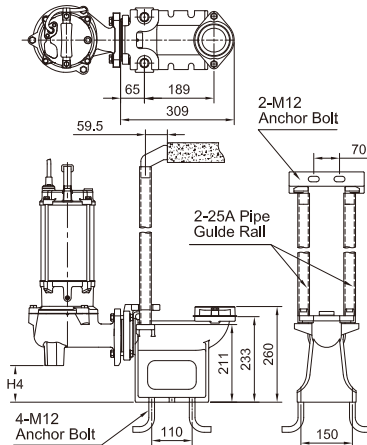

Model	TM-50/80 Guide Rail	
	DN (mm)	Dimensions H4(mm)
SD-20E-50	50	77.5
SD-20E-80	80	77.5
SD-30E-50	50	77.5
SD-30E-80	80	77.5
SV-20E-50	50	99.5
SV-20E-80	80	99.5
SV-30E-50	50	99.5
SV-30E-80	80	99.5

TL-80/100

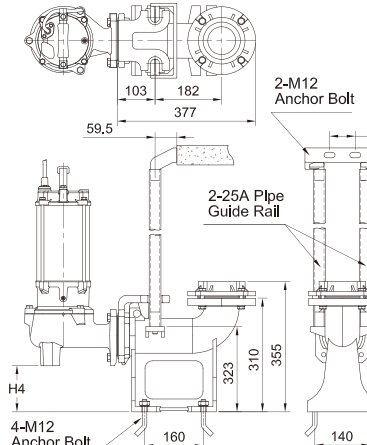

Model	TL-80/100 Guide Rail	
	DN (mm)	Dimensions H4(mm)
SD-50E-80	80	104.5
SD-50E-100	100	104.5
SD-75E-80	80	104.5
SD-75E-100	100	104.5
SV-50E-80	80	126.5
SV-50E-100	100	126.5
SV-75E-80	80	126.5
SV-75E-100	100	126.5

STS-50

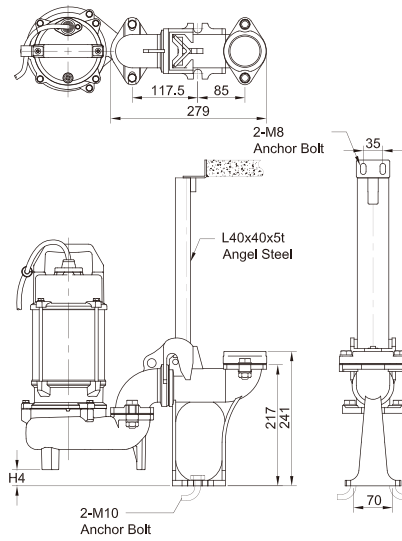

Model	STS-50 Guide Rail	
	DN (mm)	Dimensions H4(mm)
SVN-05-50	50	29
SVN-10-50	50	29
SVN-20-50	50	40

STM-50/80

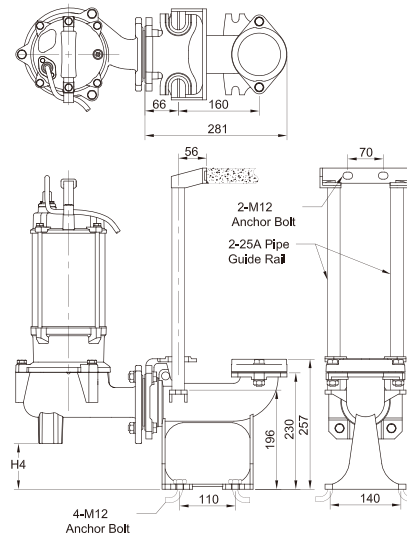

Model	STM-50/80 Guide Rail	
	DN (mm)	Dimensions H4(mm)
SVN-20E-50	50	90
SVN-20E-80	80	90
SVN-30E-50	50	90
SVN-30E-80	80	90

STL-80/100

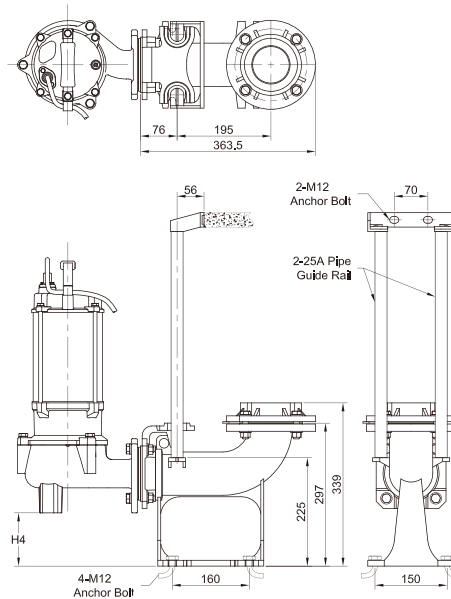

Model	STL-80/100 Guide Rail	
	DN (mm)	Dimensions H4(mm)
SVN-50E-80	80	110.5
SVN-50E-100	100	110.5
SVN-75E-80	80	104
SVN-75E-100	100	104



Model Code

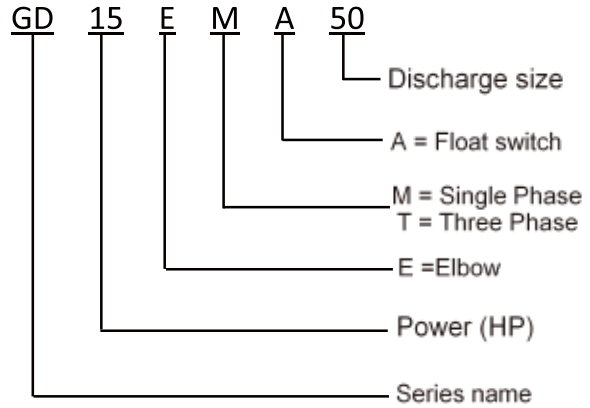

Applications

- General household use, Drainage systems for Buildings, Apartments, Resorts and Wastewater systems.
- Materials such as leather, textile fibres, food and other tougher objects can be pumped.
- Wastewater systems for Domestic, Commercial, Industrial, Municipal, Schools, Hospitals and many other uses.
- Sewage and Drainage systems.

Advantages

- Robust construction.
- Superior Heat Dissipation.
- Macerating Impeller for cutting up materials.
- Double mechanical seals Upper : CA/CE Lower : SIC/SIC

Material

NO.	Component	Material
1	Cable	H07RN-F
2	Handle	AISI304+NBR
3	Motor cover	FC200
4	Bearing cap	FC200
5	Motor frame	FC200
6	Bearing Bracket	FC200
7	M.Seal Bracket	FC200
8	Motor Shaft	AISI 410
9	Mechanical seal	CA / CE, SIC/SIC
10	Oil Seal	NBR70
11	Impeller	FC250
12	Pump casing	FC200
13	Radidl cutter	AISI 440C
14	Cutter ring	AISI 440C
15	Flange	FC200

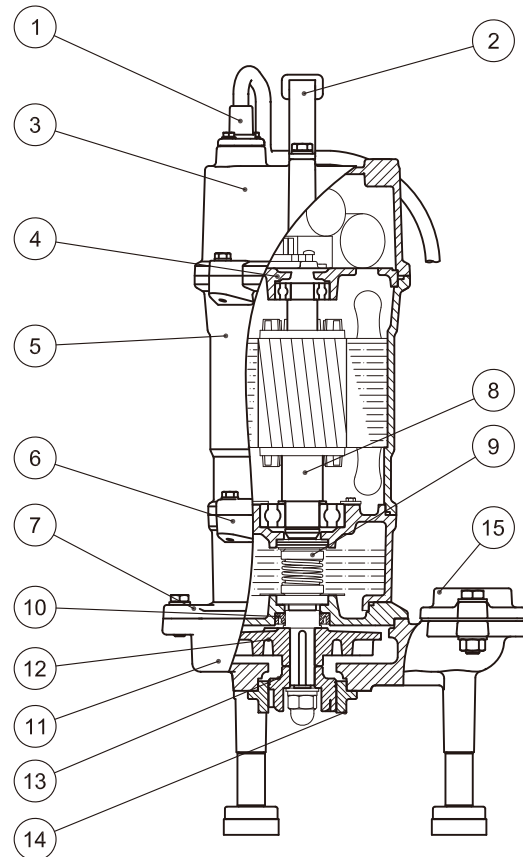

Submersible Grinder Pumps

50Hz

Performance Curves

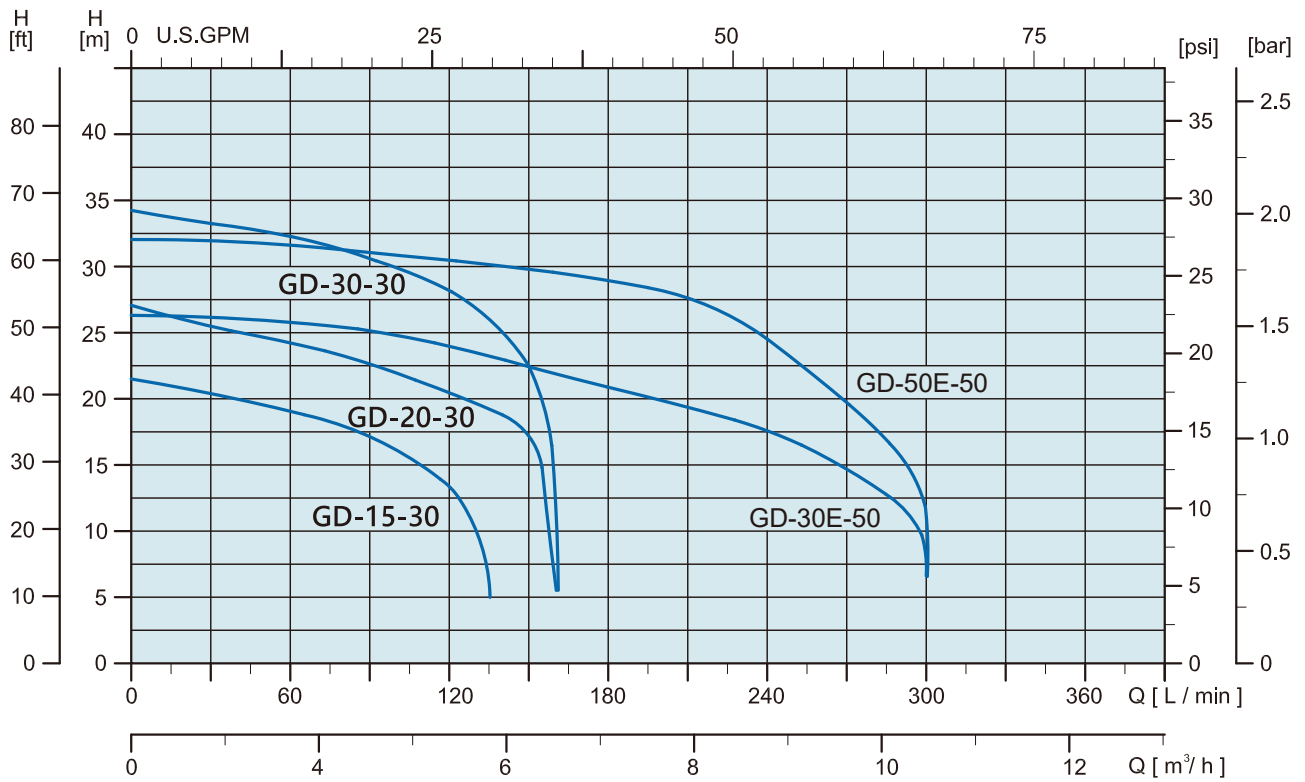

Technical Data

Single Phase

Model	Power		Nominal Current [A] 220-240V	Discharge [inch]	Head		Flow		Cable [M]	Weight [kg]
	HP	kw			Rated. (M)	Max. (M)	Rated. (L/min)	Max. (L/min)		
GD-15 M30	1.3	1.0	6.8-6.4	1 1/4"	16	21	60	140	10	27.0
GD-15 MA30										27.5
GD-20 M30	2.0	1.5	10.1-9.3	1 1/4"	24	26	60	160	10	37.5
GD-20 MA30										38.0

· A = Auto Float Switch

Three Phase

Model	Power		Nominal Current [A]		Discharge [inch]	Head		Flow		Cable [M]	Weight [kg]
	HP	kw	220-240V	380-415V		Rated (M)	Max (M)	Rated (L/min)	Max. (L/min)		
GD-15 T30	1.3	1.0	4.2-3.8	2.4-2.3	1 1/4"	16	21	60	140	10	25
GD-20 T30	2	1.5	6.0-5.5	3.6-3.4	1 1/4"	24	26	60	160	10	32
GD-30 T30	3	2.2	9.0-8.2	5.1-4.8	1 1/4"	32	34	60	160	10	37
GD-30E T50	3	2.2	9.5-8.7	5.6-5.2	2"	20	26	200	300	10	52
GD-50E T50	5	3.7	14.6-13.4	8.2-7.7	2"	31.5	27	200	300	10	55

Dimensions

Model	Phase	Discharge[mm]						DN (mm)
		A	A1	D	H	H1	H2	
GD-15-30	1	267	228	96	558	491	159	32
	3				528	461	159	
GD-20-30	1	290	251	96	605	538	159	32
	3				550	483	159	
GD-30-30	3	290	251	96	550	483	159	32
GD-30E-50	3	428	268	215	569	502	237	50
GD-50E-50	3	428	268	215	589	522	237	50

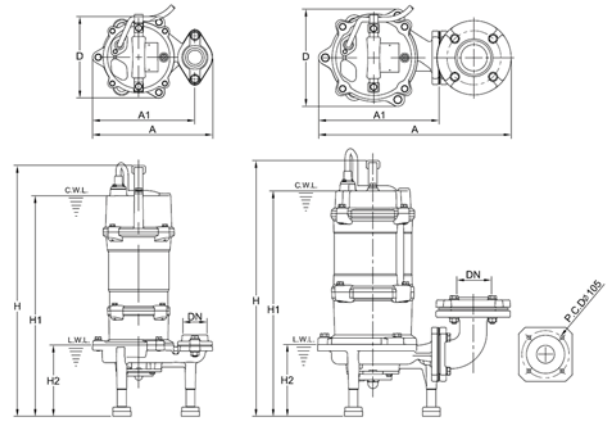

Guide Rail System

TS-32

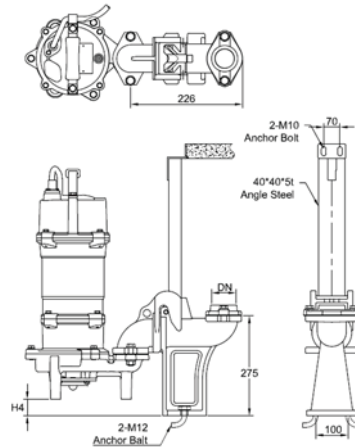

Model	TS-32 Guide Rail	
	DN (mm)	Dimensions H4 (mm)
GD-15-30	32	36
GD-20-30	32	34
GD-30-30	32	34

TG-50

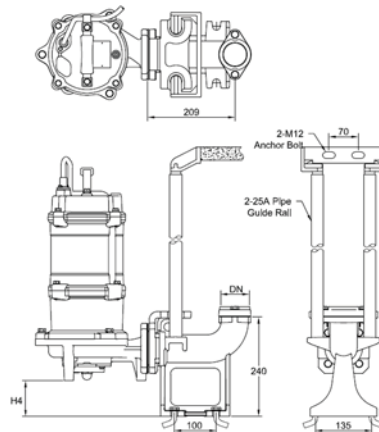

Model	TG-50 Guide Rail	
	DN (mm)	Dimensions H4 (mm)
GD-30E-50	50	88
GD-50E-50	50	88

