



Submersible Grinder Pump



INSTALLATION AND OPERATING INSTRUCTIONS



STAIRS INDUSTRIAL CO., LTD.
No. 6-7-1, Shanzijiao, Lucao Township, Chiayi County 611, Taiwan
Website: <http://www.stairs.com.tw/>
Tell: +886 5 3750488 Fax: +886 5 3755658

EC DECLARATION OF CONFORMITY

according to the following EC Directives

- Machinery Directive: 2006/42/EC
- Low Voltage Directive: 2014/35/EU
- Electromagnetic Compatibility Directive: 2014/30/EU



We, STAIRS INDUSTRIAL CO., LTD. as manufacturer declares that the machine described hereafter

Submersible Pumps

XD, XV, X1, SV, SVN, HM, SD, GD, CP Series

Provided that it is used and maintained in accordance with the general accepted codes of good practice and the recommendations of the instructions manual, meet the essential safety and health requirements of the Machinery Directive, Low Voltage Directive and Electromagnetic Compatibility Directive.

For the most specific risks of this machine, safety and compliance with the essential requirements of the Directive has been based on elements of:

EN 809, EN 60204-1, EN 60335-1, EN 60335-2-41, EN 61000-6-2, EN 61000-6-4

Signature : Mr. S. C. HUANG

Responsibility : President

Date : June



Installation

1. Check the following before beginning installation.

Insulation resistance measurement:

With the motor and cable (excluding the power supply cable) immersed in water, use a Megger to measure the insulation resistance between ground and each phase of the motor, and again between each phase of the motor. The Megger should indicate an insulation resistance of not less than 20mega ohms. While making the measurement, keep the power supply cable off the ground.

An auxiliary pump is recommended to be kept on hand in case of emergency.

2. Installation-

- (1) **! WARNING** : Under no circumstances should cable be pulled while the pump is being transported or installed. Attach a chain or rope to the grip and install the pump.
- (2) This pump must not be installed on its side or operated a dry condition. Ensure that it is installed upright on a secure base.
- (3) Install the pump at a location in the tank where there is the least turbulence.
- (4) If there is a flow of liquid inside the tank, support the piping where appropriate.
Install piping so that air will not be entrapped. If piping must be installed in

such a way that air pockets are unavoidable, install an air release valve wherever such air pockets are most likely to develop.

- (5) Do not permit end of discharge piping to be submerged, as backflow will result when the pump is shut down.
- (6) **! WARNING** : Non-automatic pumps, have an automatic operating system bump operating water level near the minimum operating level as the automatic cut-off switch incorporated inside the motor will be activated.
To avoid dry operation, install an automatic operating system, as shown in Fig-1 and maintain a safe operating water level.
- (7) For automatic pumps, install the floats as shown in Fig-2. The pump may not start if a floats switch touches the wall of the water tank or the piping. Install the floats so that this will not happen.
- (8) Adjust the float height control,,
The stop water level of the float switch must be higher than the minimum continuous running water level of the pump. Otherwise, it will cause the motor to burn out.

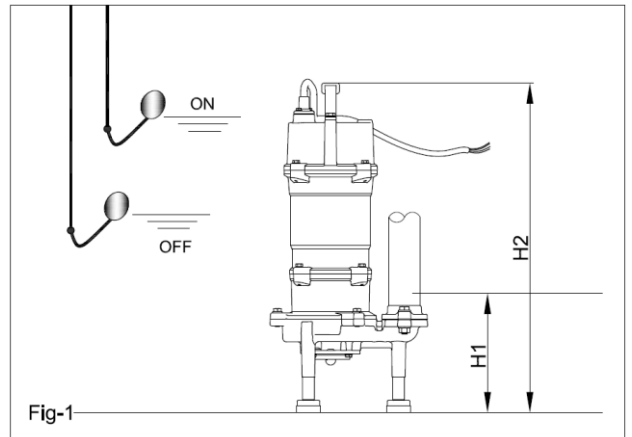

H1 : Lowest water level (Motor flange)
H2 : Operating water level This must be above the top of the motor

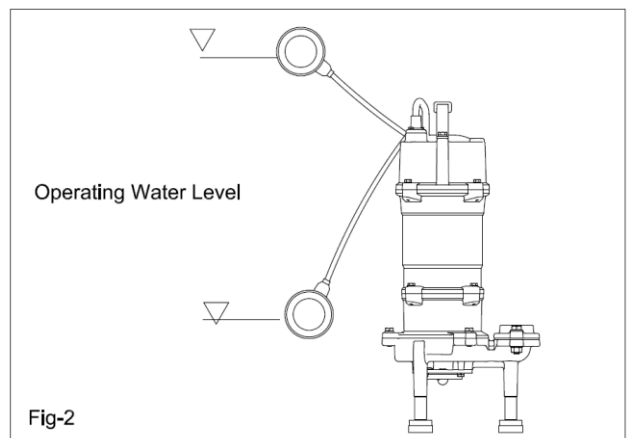

Fig-2

Electrical wiring

(1) Wiring

- a) Wire as indicated for the appropriate start system as shown in Fig-3.
- b) Loose connections will stop the pump. Make sure all electrical connections are secure.

(2) Cable

- c) **! WARNING :** Never let the end of the cable contact water.
- d) If the cable is extended, do not immerse the splice in water.
- e) Fasten the cable to the discharge piping with tape or vinyl strips.
- f) Install the cable so that it will not overheat. Overheating caused by coiling the cable and exposing it to direct sunlight.

(3) Grounding

As shown in Fig-4 ground the green wire (label E). Under no circumstances should the green wire be connected to the power supply.

- (4) **! WARNING :** Use short circuit breakers to prevent danger of electrical shock.

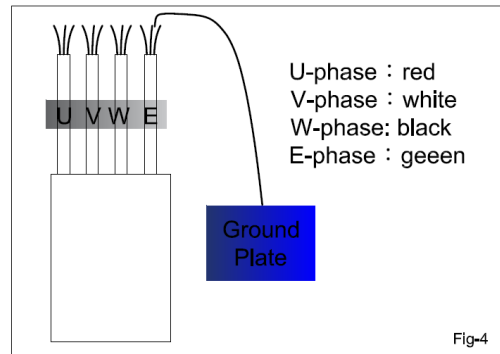
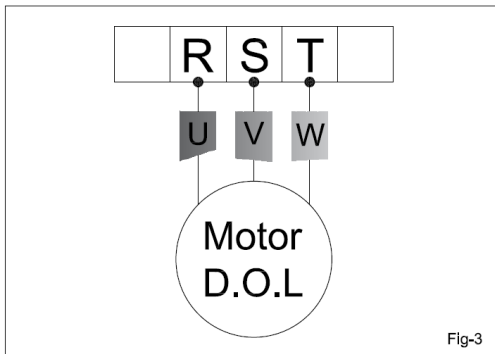

Operation.

1. Before starting the pump

- (1) After completing installation, measure the insulation resistance again as described in Installation.
- (2) Check water level.

If the pump is operated continuously for an extended period of time in a dry condition or at the lowest water level, the motor protector will be activated. Constant repetition of this action will shorten pump service life. Do not start the pump again in such a situation until after the motor has completely cooled.

2. Test operation....

Non-automatic pump

- (1) Turn the operating switch on and off a couple of times to check for normal pump start.

Automatic pump

Floating switch must be raised for the pump to start.

- (2) Next, check direction of rotation. If discharge volume is low or unusual sounds are heard when the pump is operating, rotation has been reversed. When this happens, reverse two of the wires.

Maintenance

Check pressure, output, voltage, current and other specifications. Unusual readings may indicate.

Refer to Troubleshooting and correct as soon as possible.

1. Daily inspections

(1) Check current and ammeter fluctuation daily. If ammeter fluctuation is great, even though within the limits of pump rating, foreign matter may be clogging the pump. If the quantity of liquid discharged falls suddenly, foreign matter may be blocking the suction inlet.

2. Regular inspections

(1) Monthly inspections

Measure the insulation resistance. The value should be more than 1M ohm. If resistance starts to fall rapidly even with an initial indication of over 1M ohm, this may be an indication of trouble and repair work is required.

(2) Annual inspections

To prolong the service life of the mechanical seal by replacing the oil in the mechanical seal chamber once a year. Water mixed the oil or cloudy textures are indications of a defective mechanical seal requiring replacement. When replacing the oil, lay the pump on its side with filler plug on top. Inject suitable amount turbine oil No.32 (ISO VG-32)

(3) Inspections at 3-5year intervals

Conduct an overhaul of the pump. These intervals will preclude the possibility of future trouble.

3. Parts that will need to be replaced

Replace the appropriate part when the following conditions are apparent.

Replaceable part Mechanical seal Oil filler plug O-ring Lubricating oil

Replaceable part	Mechanical seal	Oil filler plug O-ring	Lubricating oil	O-ring
Replacement guide	Whenever oil in mechanical seal chamber is clouded	Whenever oil is replaced or Inspected	Whenever clouded or dirty	Whenever pump is overhauled
Frequency	Annually	A half yearly	A half yearly	Annually

Note: above replacement schedule is based on normal operating conditions.

Motor output Part	1.0kw	1.5kw/2.2kw	2.2kw/3.7kw
Mechanical seal	20	20	30
Oil seal	ϕ 25* ϕ 40*8	ϕ 25* ϕ 40*8	ϕ 35* ϕ 52*8
Oil filler plug gasket	(Inner diameter)x(outer diameter))x(Wire diameter) ϕ 6.02* ϕ 11.26* ϕ 2.62		
Lubricating Oil (turbine oil # 32)	450c.c	600 c.c	1000c.c.

Troubleshooting

Trouble	Cause	Remedy
Pump does not start. Starts, but immediately stops	(1) Power failure (2) Large discrepancy between power source and voltage (3) Significant drop in voltage (4) Motor phase malfunction (5) Electric circuit connection faulty (6) Faulty connection of control circuit (7) Fuse blown (8) Faulty magnetic switch (9) Water is not at level indicated by Float (10) Float is not in appropriate level (11) Float effective (12) Short circuit breaker is functioning (13) Foreign matter clogging pump (14) Motor burned out (15) Motor bearing broken	(1)~(3) Contact electric power company and devise counter-measures (4) Inspect electric circuit (5) Correct wiring (6) Inspect connections and magnetic switch (7) Replace with correct type of fuse (8) Replace with correct one (9) Raise water level (10) Adjust the position of float (11) Repair or replace (12) Repair location of short circuit (13) Remove foreign matter (14) Repair or replace (15) Repair or replace
Operates, but stops after a while.	(1) Prolonged dry operation has activated motor protector and caused pump to stop (2) High liquid temperature has activated motor protector and caused pump to stop (3) Raise stop water level !WARNING :	(1) Raise stop water level (2) Lower liquid temperature (3) Correct rotation
Does not pump. Inadequate volume.	(1) Reverse rotation (2) Significant drop in voltage (3) Operating a 60Hz pump on 50Hz (4) Discharge head is high (5) Large piping loss (6) Low operating water level causes air suction (7) Leaking from discharge piping (8) Clogging of discharge piping (9) Foreign matter in suction inlet (10) Foreign matter clogging pump (11) Worn impeller	(1) Correct rotation(see Operation) (2) Contact electric power company and devise counter-measures (3) Check nameplate (4) Recalculate and adjust (5) Recalculate and adjust (6) Raise water level or lower pump (7) Inspect, repair (8) Remove foreign matter (9) Remove foreign matter (10) Remove foreign matter (11) Replace impeller
Over current	(1) Unbalanced current and voltage (2) Significant voltage drop (3) Motor phase malfunction (4) Operating 50Hz pump on 60Hz (5) Reverse rotation !WARNING : (6) Low head. Excessive volume of water (7) Foreign matter clogging pump (8) Motor bearing is worn or damaged	(1) Contact electric power company and devise counter-measure (2) Contact electric power company and devise counter-measure (3) Inspect connections and magnetic switch (4) Check nameplate (5) Correct rotation (see Operation2) (6) Replace pump with low head pump (7) Remove foreign matter (8) Replace bearing
Pump vibrates; excessive operating noise.	(1) Reverse rotation (2) Pump clogged with foreign matter (3) Piping resonates (4) Gate valve is closed too far	(1) Correct rotation (2) Disassemble and remove foreign Matter (3) Improve piping (4) Open gate valve

Disassembly and Assembly

1. Disassembly-

When disassembling pump, have a piece of cardboard or wooden board ready to place the different parts on as you work. Do not pile parts on top of each other. They should be laid out neatly in rows. The “O” ring and gasket cannot be used again once they are removed. Have replacement parts ready. Disassemble in the following order, referring to the sectional view.

!WARNING : Be sure to cut off power source beginning disassembly

- (1) Remove pump casing bolts, raise the motor section and remove pump casing.
- (2) Remove shaft head bolt and impeller.
- (3) Remove oil filler plug and drain lubricating oil.
- (4) Remove intermediate casing bolts and intermediate oil chamber.
(Remember that any lubricating oil remaining in the mechanical seal chamber will flow out.)
- (5) Carefully remove mechanical seal, taking care not to scratch sliding surface or motor shaft.

2. Assembly-

Re-assemble in reverse order of disassembly.

Be careful of the following points.

- (1) During re-assembly, rotate the impeller by hand and check for smooth rotation. If rotation is not smooth, perform steps-(3) through -(5) again.
- (2) Upon completion of re-assembly step -(1) rotate the impeller by hand from the suction the suction inlet and check that it rotates smoothly without touching the suction cover before operating the pump.

Please obtain “O” rings, shaft seals and other parts from, pump dealer. The table of dimensions is given in “Maintenance”.



STSIRS INDUSTRIAL CO.,LTD

NO.6-7-1Shanzijiao, Lucao Township,

Chiayi County 611, Taiwan

Tel: +886 (0) 53750488

Fax:+886 (0) 53755658

E-Mail: stairs@stairs.com.tw

+886 (0) 53755658