



SB, SBI, SBN

IE3 60Hz

1,3,5,10,15,20,32,45,64,90,120,150 series

Vertical Multistage Centrifugal
In-line Pumps



No. 3-8, Sanchial Tsun, Lutsao Hsiang, Chiayi County, Taiwan
Tel :+886 5 3750488 Fax:+886 5 3752330
www.stairs.com.tw E-mail:stairs@stairs.com.tw

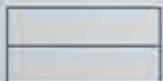

STAIRS INDUSTRIAL CO., LTD.

SB,SBI,SBN
General Data

Performance Range	1
Model Code	2
Applications	2
Pump	2
Pump/Motor Nameplate Information	3
Pumped Liquids	4
Motor	6
Motor Data	6
Mechanical Seals	7
Product Data	8
Maximum Inlet Pressure	10
Example Of Operating And Inlet Pressures	10
Material	11

Technical Data

SB(I/N) 1	14
SB(I/N) 3	18
SB(I/N) 5	22
SB(I/N) 10	26
SB(I/N) 15	30
SB(I/N) 20	34
SB(I/N) 32	38
SB(I/N) 45	42
SB(I/N) 64	46
SB(I/N) 90	50
SB(I/N) 120	54
SB(I/N) 150	56
SB(I/N) 200	58

Accessories

Pipework Connections	60
Counter flanges for SB(I/N)	60
Victaulic couplings for SBI(N)	61
Oval flanges for SB(I/N)	61

SB series pumps are vertical multistage centrifugal pumps.

Stairs' vertical centrifugal pump is made by Stairs' latest technology and profession. SB/I/N pump is an energy saving, non-self priming pump, and coupled to a standard premium efficient motor; and it enables to be work easily in different and wide application.

It's built to suit a variety of aggressive and high temperature liquids, and is designed to reduce lifecycle costs in a wide range of demanding applications such as water supply, pressure boosting, industrial circulation systems, process water, cooling water circulation system, fire-extinguishing system and irrigation, heating and air-conditioning.

The pump consists various types of connections (IEC, ANSI or JIS) to meet the international standard.

Performance Range

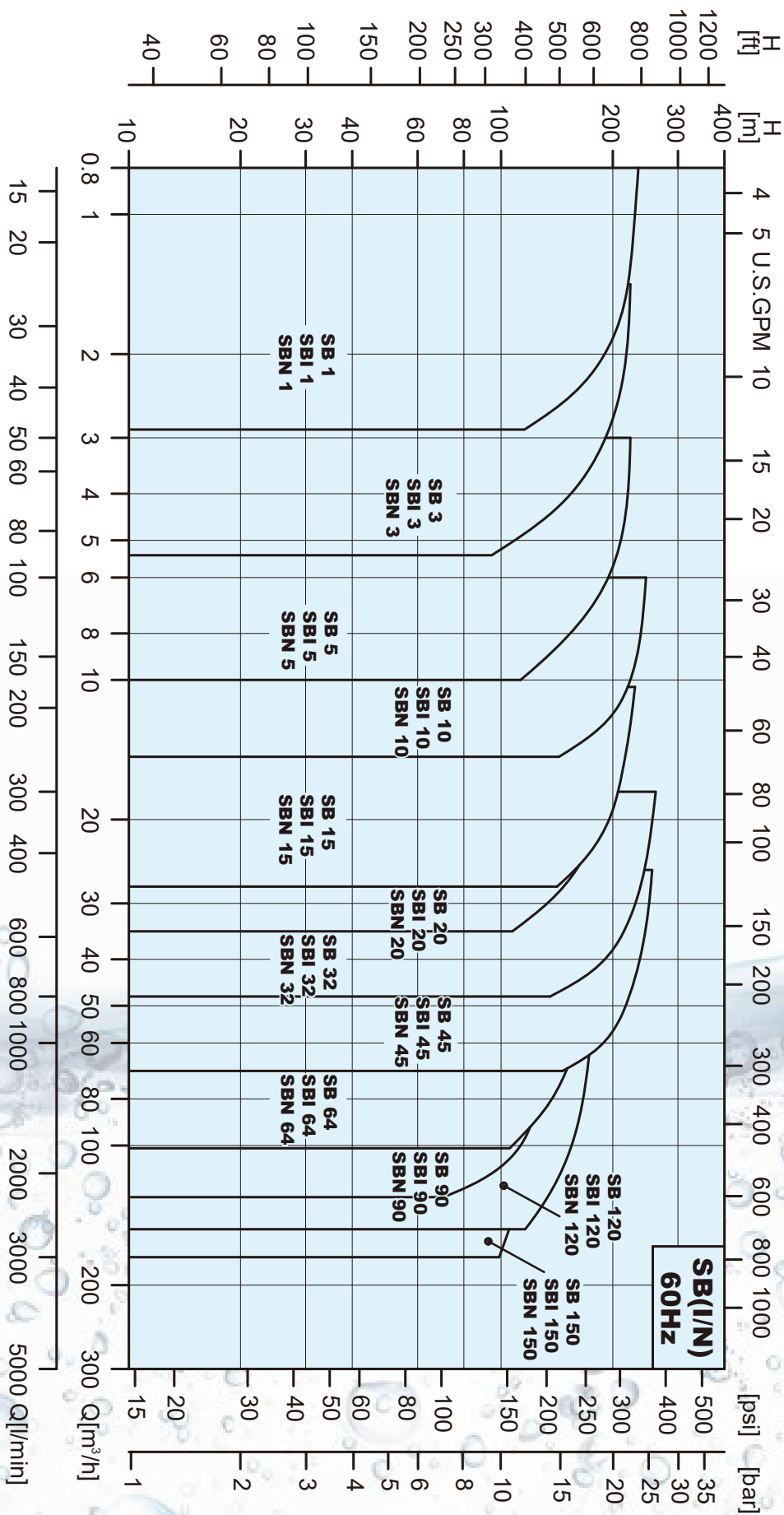



Model Code

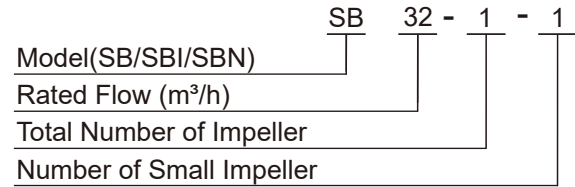

* Impeller with small diameter

Applications

■ Water supply and pressure boosting

- Pressure boosting in buildings, hotels, residential complexes
- Pressure booster stations, supply of water networks
- Pressure boosting for industrial water supply

■ Light industry

- Washing and cleaning systems
- Car washing facilities
- Fire fighting systems
- Process water systems
- Machine tools (cooling lubricants)

■ Heating, ventilation and air-conditioning

- Boilers
- Induction heating
- Heat exchangers
- Refrigerators
- Cooling towers and systems
- Temperature control systems

■ Irrigation and agriculture

- Greenhouses
- Sprinkler irrigation
- Field irrigation (flooding)

■ Water treatment

- Water softeners and de-mineralization
- Reverse Osmosis systems
- Distillation systems
- Filtration
- Ultra-filtration systems

Pump

The SB, SBI and SBN pumps are non-self priming vertical multistage pump of in-line design, flange or with Victaulic coupling with equally sized suction and discharge ports.

Stage construction with stainless steel impellers, chambers and pressure casing.

All pumps are equipped with a cartridge type mechanical seal for easy maintenance.

SB, SBI and SBN pumps have different pump sizes and various numbers of stages to provide the flow and the pressure required.

Pump Nameplate Information

Type	①				
Model	②				
f	③	Hz	P2	⑨	kW
n	④	min ⁻¹	H _{max}	⑩	m
Q	⑤	m ³ /h	H	⑪	m
p _{max} /t _{max}	⑥		bar/°C		
Serial No.	⑦		⑫		

CE

- ① Pump Type
- ② Pump Model
- ③ Frequency
- ④ Revolutions Per Minute
- ⑤ Flow rate
- ⑥ Max. Operating Pressure / Max. temperature
- ⑦ Date of manufacture
- ⑧ Seal Type
- ⑨ Rated Output Power
- ⑩ Maximum Head
- ⑪ Rated Head
- ⑫ Serial number

Motor Nameplate Information

27x70mm

A. 0.5 - 1.5 Hp(1-PHASE)

STAIRS 1-PHASE INDUCTION MOTOR						CE
TYPE	②	FR.	③	RATING CONT.		
OUTPUT	④ HP	kW	INS.	⑤	POLES	IP ⑥ IEC 60034
50 Hz	⑧ V		⑨ A			
	E.E.F.%	⑩	rpm		⑪	
BEARINGS	⑫ ZZ C3		ZZ C3		WEIGHT	kg
SER.NO.	⑬		MADE IN TAIWAN DATE			

B. 0.5 - 1.0 Hp(3-PHASE,Dual voltage,Dual frequency)

STAIRS 3-PHASE INDUCTION MOTOR						CE
TYPE	②	FR.	③	RATING CONT.		
OUTPUT	④ HP	kW	INS.	⑤	POLES	IP ⑥ IEC 60034
50 Hz	Δ	⑧ V	⑨ A	E.E.F.%	⑩	
	Y	V	A	rpm	⑪	
60 Hz	Δ	V	A	E.E.F.%		
	Y	V	A	rpm	⑪	
BEARINGS	⑫ ZZC3		ZZC3		WEIGHT	kg
SER.NO.	V	⑬		DATE		

50x80mm

C. 2.0 - 3.0 Hp(1-PHASE)

STAIRS 1-PHASE INDUCTION MOTOR						CE
TYPE	②	FR.	③	POLES 2	IEC 60034	
OUTPUT	④ HP	kW	RATING CONT.	INS.	⑤	IP ⑥
⑦ Hz	⑧ V		⑨ A			
	E.E.F.%	⑩	rpm		⑪	
BEARINGS	⑫		WEIGHT		kg	
SER.NO.	⑬		DATE			

D. 1.5 - 30 Hp(3-PHASE,Dual voltage,Dual frequency)

STAIRS 3-PHASE INDUCTION MOTOR						CE
TYPE	②	FR.	③	POLES 2	IEC 60034	
OUTPUT	④ HP	kW	RATING CONT.	INS.	⑤	IP ⑥
50 Hz	Δ	⑧ V	⑨ A	E.E.F.%	⑩	
	Y	V	A	rpm		
60 Hz	Δ	V	A	E.E.F.%		
	Y	V	A	rpm	⑪	
BEARINGS	⑫		WEIGHT		kg	
SER.NO.	⑬		DATE			

E. 40 - 100 Hp (single frequency)

STAIRS ① INDUCTION MOTOR						CE
TYPE	②	FR.	③	POLES 2	IEC 60034	
OUTPUT	④ HP	kW	RATING CONT.	INS.	⑤	IP ⑥
⑦ Hz	Δ	⑧ V	⑨ A	E.E.F.%	⑩	
	Y	V	A	rpm	⑪	
BEARINGS	⑫		WEIGHT		kg	
SER.NO.	⑬		DATE			

- ① Phase
- ② Motor Model
- ③ Frame
- ④ Rated Power
- ⑤ Insulation
- ⑥ International Protection
- ⑦ Frequency
- ⑧ Voltage
- ⑨ Ampere
- ⑩ Efficiency
- ⑪ Revolutions Per Minute
- ⑫ Bearing Type
- ⑬ Serial Number

HP	1Ø			3Ø				
	110/220V	220-240V	220-277V / 380-480V	220-277V / 380-480	380-480V / 660-830V	220-240V / 380-415V	380-415V / 660-720V	460V
0.5	A	—	B	—	—	—	—	—
0.75	A	—	B	—	—	—	—	—
1.0	A	—	B	—	—	—	—	—
1.5	—	A	D	—	—	—	—	—
2.0	—	C	—	D	—	—	—	—
3.0	—	C	—	D	—	—	—	—
4.0	—	—	—	D	D	—	—	—
5.5	—	—	—	D	D	—	—	—
7.5	—	—	—	D	D	—	—	—
10.0	—	—	—	D	D	—	—	—
15.0	—	—	—	D	D	—	—	—
20.0	—	—	—	D	D	—	—	—
25.0	—	—	—	D	D	—	—	—
30.0	—	—	—	D	D	—	—	—
40.0	—	—	—	—	—	E	E	E
50.0	—	—	—	—	—	E	E	E
60.0	—	—	—	—	—	E	E	E
75.0	—	—	—	—	—	E	E	E
100.0	—	—	—	—	—	E	E	E

Pumped Liquids

SB (I,N) pumps can handle a wide variety of liquids, each with its own characteristic.

SB (I)

Non-corrosive liquids

For fluid transfer, circulation and pressure boosting of cold or hot clean water.

SBN

Industrial liquids

Light acids

The fluids covered in the list are not complete. Data on the application limits of different pump materials when handling any of the listed fluids are considered to be the best choices.

However, the table is intended as a general guide only, and cannot replace actual testing of the pumped fluids and pump materials under specific working conditions.

When choosing the pump version, sufficient attention should be given to the flow medium, such as density, solidification point, viscosity as well as ex-protection requirement. The limits of applicability of the pumps, based on pressure and temperature must also be considered.

- Recommended

Pumped Fluid	Fluid Concentration,temperature	SB(I)		SBN	
		EPDM	Viton	EPDM	Viton
Acetic acid anhydride	25°C			•	
Alkaline cleaner		•			
Aluminium sulphate	10%,25°C				•
Ammonia water (A.hydroxide)	20%,40°C	•			
Ammonia hydrogen carbonate	10%,40°C	•		•	
Benzoic acid	10%,90°C				•
Boric acid	Unsaturated solution,60°C				•
Butanol	60°C	•			
Calcium acetate	30%, 50°C	•			
Calcium hydroxide	Saturated solution, 50°C	•			
Chromic acid	1%, 20°C				•
Condensate	90°C	•			
Copper sulphate	Unsaturated solution,60°C				•
Deionic (fully desalinated water)	50°C			•	
Ethanol	100%,20°C	•			
Ethylene glycol/Diethylene glycol	40%,70°C	•	•	•	•
Fixer	25°C				•
Formic acid	5%,20°C			•	
Fruit juice	50°C				•
Glycerine	50%,50°C	•			
Heating oil (Light)		•			•
Hydraulic oil	100%,100°C		•		
Isopropanol		•			
Lactic acid	10%,20°C				•
Linoleic acid	100%,20°C	•			
Linseed oil	60°C		•		
Liqueur	60°C				•
Maize oil	80°C		•		

Pumped Fluid	Fluid Concentration,temperature	SB(I)		SBN	
		EPDM	Viton	EPDM	Viton
Maleic acid	50%,50°C				●
Methanol	100%,20°C	●			
Motor oil	100%,80°C	●			
Oil-water-mixture	100°C		●		
Oxalic acid	1%,20°C			●	
Peanut oil	100%,80°C		●		
Phosphoric acid	20%,20°C			●	
Polyglycols	90°C		●		●
Polyethylene glycols	40%,70°C	●			
Potassium carbonate	10%,60°C	●			
Potassium hydrogen carbonate	10%,60°C	●			
Potassium permanganate	5%,20°C			●	
Potassium sulphate	Unsaturated solution,80°C			●	
Rapeseed oil	100%,80°C		●		
Silicone oil	100%		●		
Sodium carbonate	10%,60°C			●	
Sodium hydroxide	25%,50°C			●	
Sodium nitrate	Unsaturated solution,80°C			●	
Sodium phosphate	5%,100°C			●	
Sodium sulphate	10%,60°C			●	
Sulphuric acid	5%,25°C				●
Water					
Swimming pool water	35°C	●SBI		●	
Deionic	50°C			●	
Distilled water	50°C			●	
Decarbonated water				●	
Soft water				●	
Heating water				●	
Boiler water				●	
Pure water				●	
Rinsing water		●SBI		●	

Motor

- Squirrel cage in short circuit, aluminum casing up to 22 kW, totally enclosed, fan-cooled, 2-pole standard motor.
- Standard supply STAIRS motors up to 22 kW. Other motor brands for higher powers.
- Electrical data
 - Enclosure class : IP55
 - Insulation class : F
- The motors have efficiency values that fall within the range normally referred to as high efficiency.
- Ambient temperature : Max.+50°C

Motor Data

Motor Type				Nominal current in [A]							
pole	HP	kW	Flange	Frame	1Ø		3Ø		3Ø		
					110 / 220V	220 - 240V	Δ 220 - 277V	Y 380 - 480V	Δ 380 - 480V	Y 660 - 830V	
2	0.5	0.37	B14	71A	6.2 / 3.1	—	1.7 - 1.6	1.0 - 0.9	—	—	
	0.75	0.55		71B	8.0 / 4.0	—	2.4 - 2.3	1.4 - 1.3	—	—	
	1.0	0.75		80A	10.4 / 5.2	—	3.1 - 3.0	1.8 - 1.7	—	—	
	1.5	1.1		80B	—	7.6 - 8.9	4.0 - 3.8	2.3 - 2.2	—	—	
	2.0	1.5		90S	—	9.6 - 9.7	5.7 - 5.4	3.3 - 3.1	—	—	
	3.0	2.2		90L	—	13.8 - 12.5	8.1 - 7.2	4.7 - 4.2	—	—	
	4.0	3.0		100L	—	—	11.1 - 9.7	6.4 - 5.6	6.6 - 5.4	3.8 - 3.1	
	5.5	4.0		112M	—	—	14.3 - 13.1	8.3 - 7.6	8.2 - 7.0	4.7 - 4.0	
	7.5	5.5		B5	132S	—	—	19.2 - 16.9	11.1 - 9.8	11.2 - 9.6	6.5 - 5.5
	10.0	7.5	132S		—	—	25.4 - 22.1	14.7 - 12.8	14.9 - 13.3	8.6 - 7.7	
	15.0	11.0	160M		—	—	37.0 - 33.9	21.4 - 19.6	21.5 - 20.6	12.4 - 11.9	
	20.0	15.0	160M		—	—	48.5 - 40.7	28.0 - 23.5	28.5 - 24.9	16.4 - 14.3	
	25.0	18.5	160L		—	—	59.7 - 49.3	34.5 - 28.5	34.6 - 28.9	19.9 - 16.6	
	30.0	22.0	180M		—	—	70.4 - 58.5	40.7 - 33.8	41.1 - 34.3	23.7 - 19.8	
			B5		Frame	3Ø		3Ø		3Ø	
						Δ 220 - 240V	Y 380 - 415V	Δ 380 - 415V	Y 660 - 720V	Δ 460V	
	40.0	30.0			200L	93.5 - 85.5	54.0 - 49.5	54.0 - 49.5	31.1 - 28.5	52.1	—
	50.0	37.0		200L	113.0 - 103.6	65.0 - 59.5	65.0 - 59.5	37.0 - 33.9	64.0	—	
60.0	45.0	225M		137.0 - 125.6	79.0 - 72.3	79.0 - 72.3	45.0 - 41.3	77.6	—		
75.0	55.0	250M		168.0 - 154.0	97.0 - 88.8	97.0 - 88.8	56.0 - 51.3	94.6	—		
100.0	75.0	280S	224.0 - 205.3	130.0 - 119.0	130.0 - 119.0	75.0 - 68.8	128.4	—			

Mechanical Seals

Standard Cartridge type mechanical seal made of Silicon Carbide/Silicon Carbide/EPDM or Viton. Based on the type of application, alternative materials are available for the seal and the elastomers. The cartridge type mechanical seal can be replaced in minutes without special tools and without dismantling the pump.

Seal Type	SB,SBI,SBN		
	1,3,5,10,15, 20,32,45,64,90	120,150	
		0.5-60HP	75.0-100.0HP
S: O-ring seal Cartridge type	●	●	-
B: Rubber bellows seal Cartridge type	-	-	●
Seals Face Material			
QQ	●	●	●
UU	○	○	-
QB	○	○	-
UB	○	○	-
Rubber Material			
E	●	●	●
V	○	○	○

List of Materials	
Q : Silicon Carbide	E: EPDM
U: Tungsten Carbide	V: Viton
B: Carbon	



● Std. ○ Opt. - N/A

Minimum inlet pressure - NPSHA

Calculation of the inlet pressure "H" is recommended in these situations:

- The liquid temperature is high.
- The flow is significantly higher than the rated flow.
- Water is drawn from depths.
- Water is drawn through long pipes.
- Inlet conditions are poor.

To avoid cavitation, make sure that there is a minimum pressure on the suction side of the pump.

The maximum suction lift "H" in feet can be calculated as follows:

$$H = P_b - NPSHR - H_f - H_v - H_s$$

P_b = Barometric pressure in feet absolute.

(Barometric pressure can be set to 33.9 feet.

At sea level. In closed systems, P_b indicates system pressure in feet.)

NPSHR = Net Positive Suction Head Required in feet.

(To be read from the NPSHR curve at the highest flow the pump will be delivering.)

H_f = Friction loss in suction pipe in feet.

(At the highest flow the pump will be delivering.)

H_v = Vapor pressure in feet.

(To be read from the vapor pressure scale.

" H_v " depends on the liquid temperature " T_m ".

H_s = Safety margin = minimum 2.0 feet.

If the "H" calculated is positive, the pump can operate at a suction lift of maximum "H" feet.

If the "H" calculated is negative, an inlet pressure of minimum "H" feet is required.

Note: In order to avoid cavitation never, select a pump whose duty point lies too far to the right on the NPSHR curve.

Always check the NPSHR value of the pump at the highest possible flow.

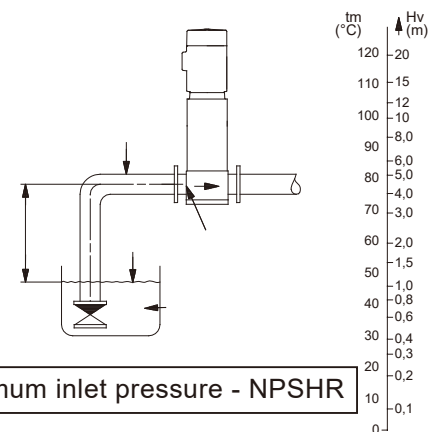

Minimum inlet pressure - NPSHR

Product Data

Range	1	3	5	10	15	20
Nominal flow (m ³ /h)	2.2	3.6	6.9	12.1	22.0	25.3
Flow range (m ³ /h)	0.8-2.9	1.5-5.4	3.0-10.0	6.0-15.5	10.5-28	12.5-35
Max. pressure (bar)	23.5	23.3	23.0	24.5	23.5	20.5
Fluid temperature (°C)	-15 to +120					
Motor power (kW)	0.37-3.0	0.37-4.0	0.55-7.5	0.75-11	1.5-18.5	2.2-18.5
Version						
SB: Cast iron and Stainless steel EN 1.4301/AISI 304	●	●	●	●	●	●
SBI: Stainless steel EN 1.4301/AISI 304	●	●	●	●	●	●
SBN: Stainless steel EN 1.4401/AISI 316	●	●	●	●	●	●
Motor						
Mains connection 1~(V)	0.37-0.75kW 110 / 220V					
	1.1-2.2kW 220-240V					
Mains connection 3~(V)	0.37 - 1.85 kW 220-277V / 380-480V					
	3.0-18.5kW 380-480V / 660-830V					
Insulation class	F					
Enclosure class	IP 55					
Ambient temperature	50°C					
SB, SBI, SBN Pipe Connection						
Flange	DN 25 DN 32	DN 25 DN 32	DN 25 DN 32	DN 40	DN 50	DN 50
Oval Flange	RP/NPT 1"	RP/NPT1"	RP/NPT 1 ¼"	RP/NPT 1 ½"	RP/NPT 2"	RP/NPT 2"
SBI, SBN Pipe Connection						
Victaulic-connections	R 1 ¼	R 1 ¼	R 1 ¼	R 2	R 2	R 2
Mechanical Seals						
SiC/SiC	Standard					
Seals						
EPDM	Standard					
Viton						

* Flange standards : Refer to dimensional drawings

Product Data

Range	32	45	64	90	120	150
Nominal flow (m³/h)	36.0	54.0	77.0	108.0	144.0	180.0
Flow range (m³/h)	18.0-48.0	26.0-70.0	36.0-102.0	54.0-144.0	60.0-160.0	78.0-180.0
Max. pressure (bar)	27.0	26.0	17.8	15.9	18.5	15.3
Fluid temperature (°C)	-15 to +120					
Motor power (kW)	2.2-30.0	5.5-45.0	7.5-45.0	11.0-45.0	18.5-75.0	18.5-75.0
Version						
SB: Cast iron and Stainless steel EN 1.4301/AISI 304	●	●	●	●	●	●
SBI: Stainless steel EN 1.4301/AISI 304	●	●	●	●	●	●
SBN: Stainless steel EN 1.4401/AISI 316	●	●	●	●	●	●
Motor						
Mains connection 1~ (V)	2.2kW		220-240 V			
Mains connection 3~ (V)	2.2-22.0kW		220-277 V / 380-480 V			
	3.0-22.0kW		380-480 V / 660-830 V			
	30.0-75.0kW		220-240 V / 380-415 V			
	30.0-75.0kW		380-415 V / 660-720 V			
	30.0-75.0kW		460V			
Insulation class	F					
Enclosure class	IP 55					
Ambient temperature	50°C					
SB, SBI, SBN Pipe Connection						
Flange	DN65	DN80	DN100	DN100	DN125	DN125
SBI, SBN Pipe Connection						
Victaulic-connections	N/A	N/A	N/A	N/A	N/A	N/A
Mechanical Seals						
SiC/SiC	Standard					
Seals						
EPDM	Standard					
Viton	Standard					

* Flange standards : Refer to dimensional drawings

Maximum Inlet Pressure

The following table shows the maximum permissible inlet pressure. However, the current inlet pressure + the pressure against a closed valve must always be lower than the maximum permissible operating pressure. If the maximum permissible operating pressure is exceeded, the bearing in the motor may be damaged and the life of the shaft seal reduced.

Pump type	Flange & Victaulic				Oval Flange		
	Stages	Max. Operating Pressure	Stages	Max. Inlet Pressures	Stages	Max. Operating Pressure	Max. Inlet Pressures
SB(I/N) 1	2 - 27	25 bar	2 - 25	10 bar	2 - 17	16 bar	10 bar
			27	15 bar			
SB(I/N) 3	2 - 25	25 bar	2 - 15	10 bar	2 - 15	16 bar	10 bar
			17 - 25	15 bar			
SB(I/N) 5	2 - 24	25 bar	2 - 9	10 bar	2 - 16	16 bar	10 bar
			10 - 24	15 bar			
SB(I/N) 10	1 - 10	16 bar	1 - 5	8 bar	1 - 10	10 bar	8 bar
	12 - 17	25 bar	6 - 17	10 bar			
SB(I/N) 15	1 - 8	16 bar	1 - 2	8 bar	1 - 5	10 bar	8 bar
	9 - 12	25 bar	3 - 12	10 bar			
SB(I/N) 20	1 - 7	16 bar	1	8 bar	1 - 5	10 bar	8 bar
	8 - 10	25 bar	2 - 10	10 bar			
SB(I/N) 32	(1-1) - 5	16 bar	(1-1) - 2	4 bar			
	(6-2) - (10-2)	30 bar	(3-2) - 6	10 bar			
			(7-2) - (10-2)	15 bar			
SB(I/N) 45	(1-1) - 4	16 bar	(1-1) - 1	4 bar			
	(5-2) - 7	30 bar	(2-2) - 3	10 bar			
			(4-2) - 7	15 bar			
SB(I/N) 64	(1-1) - 3	16 bar	(1-1)	4 bar			
	(4-2) - (5-2)	30 bar	1 - (2-1)	10 bar			
				2 - (5-2)	15 bar		
SB(I/N) 90	(1-1) - 3	16 bar	(1-1) - (2-2)	10 bar			
	(4-2)	30 bar	(2-1) - (4-2)	15 bar			
SB(I/N) 120	1 - (5-2)	30 bar	1	10 bar			
			(2-2) - (3-1)	15 bar			
			3 - (5-2)	20 bar			
SB(I/N) 150	(1-1) - (4-2)	30 bar	(1-1)	10 bar			
			1 - 2	15 bar			
			(3-2) - (4-2)	20 bar			

* Rule to follow : The inlet pressure+the pressure against a closed valve < Max.Operating pressure.

Example Of Operating And Inlet Pressures

The values for operating and inlet pressures shown in the tables must not be considered individually but must always be compared, see the following examples:

Example 1:

The following pump type has been selected: SB 64-4

Max. operating pressure: 30 bar

Max. inlet pressure: 15 bar

Discharge pressure against a closed valve: 16.7 bar , (see p.46)

This pump is not allowed to start at an inlet pressure of 15 bar , but at an inlet pressure of 30 bar - 16.7 bar = 13.7 bar.

Example 2:

The following pump type has been selected:SB 10-2

Maximum operating pressure: 16 bar.

Maximum inlet pressure: 8 bar.

Discharge pressure against a closed valve: 2.9 bar (97ft). (See p.26)

This pump is allowed to start at an inlet pressure of 8 bar, as the discharge is only 2.9 bar, which results in an operating pressure of 8 bar + 2 bar = 10 bar.

On the contrary, the maximum operating pressure of this pump is limited to 10.9 bar as a higher operating pressure will require an inlet pressure of more than 8 bar.

Material

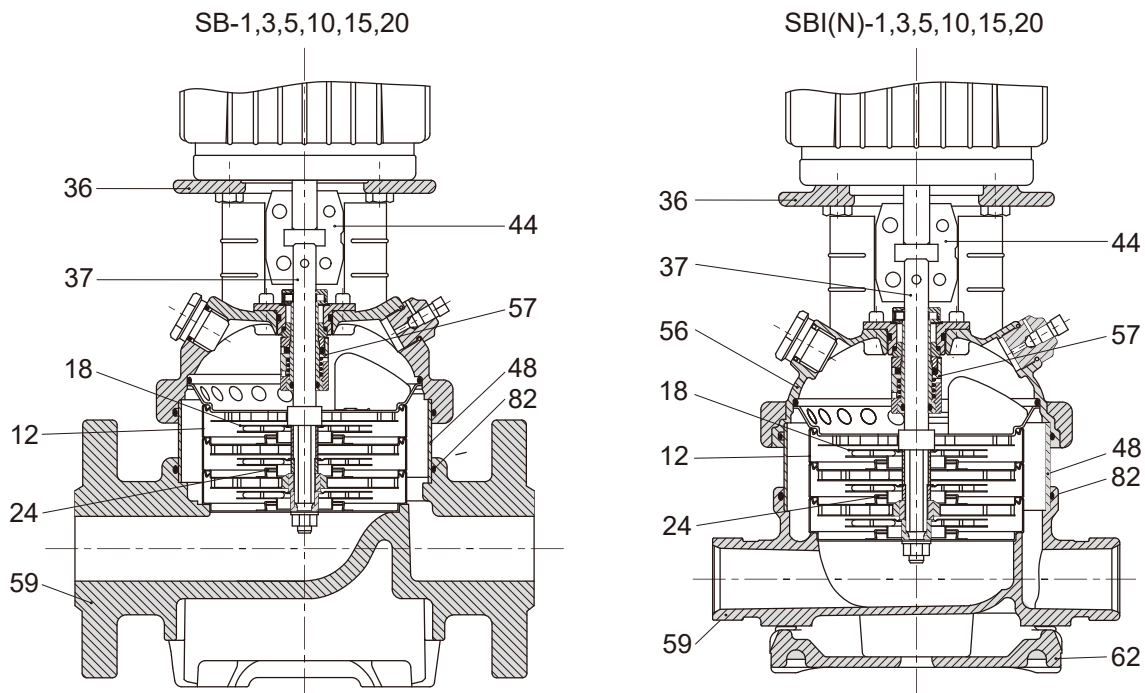

Pos.	Name	Material	SB 1,3,5,10,15,20		SBI 1,3,5,10,15,20		SBN 1,3,5,10,15,20	
			Standard		Standard		Standard	
			Europe	USA	Europe	USA	Europe	USA
36	Pump head	Cast Iron	EN-GJL-200	ASTM 25B	EN-GJS-450-10	ASTM 65-45-12	EN-GJS-450-10	ASTM 65-45-12
56	Pump head cover	Stainless steel	N/A		1.4301	AISI 304	1.4401	AISI 316
18	Impeller	Stainless steel	1.4301	AISI 304	1.4301	AISI 304	1.4401	AISI 316
37	Shaft	Stainless steel	1.4057	AISI 431	1.4057	AISI 431	1.4401	AISI 316
48	Outer Sleeve	Stainless steel	1.4301	AISI 304	1.4301	AISI 304	1.4401	AISI 316
82	O-ring for outer sleeve	EPDM						
12	Chamber	Stainless steel	1.4301	AISI 304	1.4301	AISI 304	1.4401	AISI 316
24	Neck ring	PTFE						
59	Base	Cast Iron	EN-GJL-200	ASTM 25B	N/A			
		Stainless steel	N/A		1.4301	AISI 304	1.4401	AISI 316
62	Base plate	Cast Iron	N/A		EN-GJL-200	ASTM 25B	EN-GJL-200	ASTM 25B
44	Coupling	Sintered metal						
57	Mechanical Seal	Cartridge type						

Material

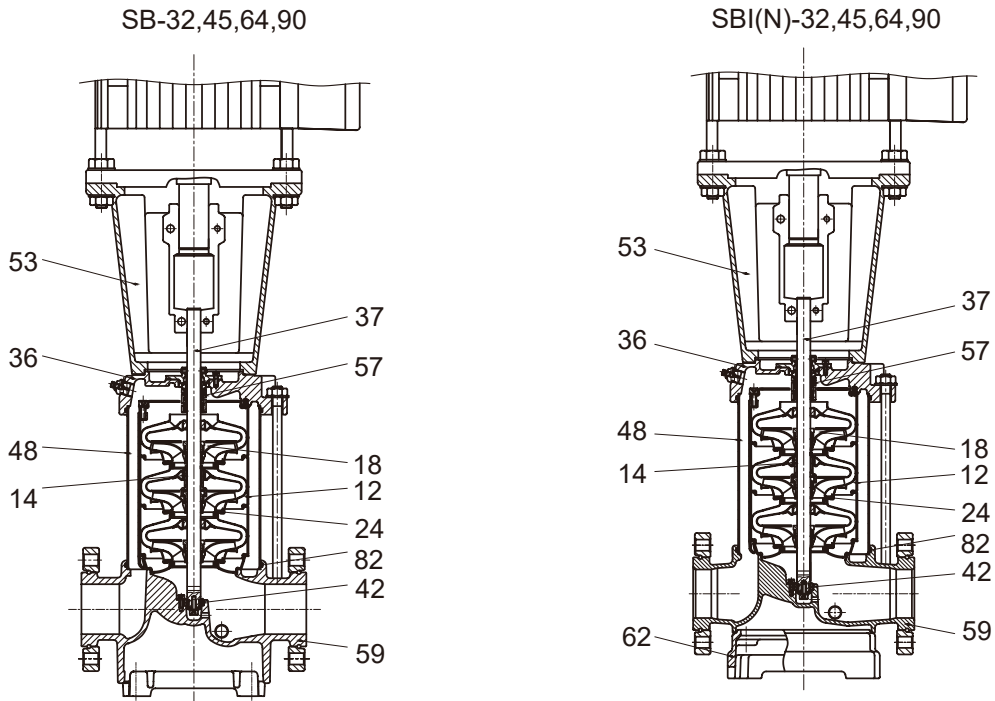

Pos.	Name	Material	SB 32,45,64,90		SBI 32,45,64,90		SBN 32,45,64,90	
			Standard		Standard		Standard	
			Europe	USA	Europe	USA	Europe	USA
36	Pump head	Cast Iron	EN-GJL-250	ASTM 35B				
		Stainless steel			1.4301	AISI 304	1.4401	AISI 316
53	Motor Bracket	Cast Iron	EN-GJL-250	ASTM 35B	EN-GJL-250	ASTM 35B	EN-GJL-250	ASTM 35B
18	Impeller	Stainless steel	1.4301	AISI 304	1.4301	AISI 304	1.4401	AISI 316
37	Shaft	Stainless steel	1.4057	AISI 431	1.4057	AISI 431	1.4401	AISI 316
48	Outer Sleeve	Stainless steel	1.4301	AISI 304	1.4301	AISI 304	1.4401	AISI 316
82	O-ring for outer sleeve	EPDM						
12	Chamber	Stainless steel	1.4301	AISI 304	1.4301	AISI 304	1.4401	AISI 316
24	Neck ring	Carbon Fiber + POB + PTFE						
59	Base	Cast Iron	EN-GJL-250	ASTM 35B	N/A			
		Stainless steel	N/A		1.4301	AISI 304	1.4401	AISI 316
62	Base plate	Cast Iron	N/A		EN-GJL-250	ASTM 35B	EN-GJL-250	ASTM 35B
57	Mechanical seal	Cartridge type						
14	Bearing ring		Bronze				POB+Graphite+PTFE	
42	Bottom Bearing ring	Tungsten carbide/ Tungsten carbide						

Material

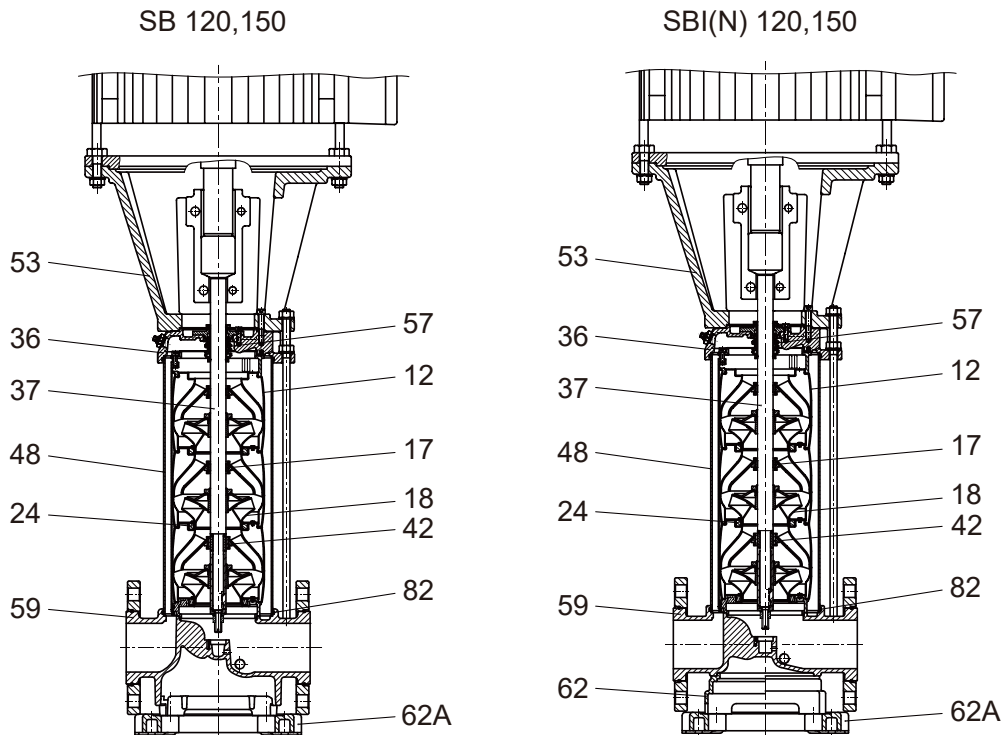

Pos.	Name	Material	SB 120,150		SBI 120,150		SBN 120,150	
			Standard		Standard		Standard	
			Europe	USA	Europe	USA	Europe	USA
36	Pump head	Cast Iron	EN-GJL-250	ASTM 35B	N/A			
		Stainless steel	N/A		1.4301	AISI 304	1.4401	AISI 316
53	Motor Bracket (15HP~60HP)	Cast Iron	EN-GJL-250	ASTM 35B	EN-GJL-250	ASTM 35B	EN-GJL-250	ASTM 35B
	Motor Bracket (75HP~100HP)	Cast Iron	EN-GJS-450-10	ASTM 65-45-12	EN-GJS-450-10	ASTM 65-45-12	EN-GJS-450-10	ASTM 65-45-12
17	Bearing ring	PTFE						
18	Impeller	Stainless steel	1.4301	AISI 304	1.4301	AISI 304	1.4401	AISI 316
37	Shaft	Stainless steel	1.4057	AISI 431	1.4057	AISI 431	1.4401	AISI 316
48	Outer Sleeve	Stainless steel	1.4301	AISI 304	1.4301	AISI 304	1.4401	AISI 316
82	O-ring for outer sleeve	EPDM						
12	Chamber	Stainless steel	1.4301	AISI 304	1.4301	AISI 304	1.4401	AISI 316
24	Neck ring	PTFE						
59	Base	Cast Iron	EN-GJL-250	ASTM 35B	N/A			
		Stainless steel	N/A		1.4301	AISI 304	1.4401	AISI 316
62	Base plate	Cast Iron	N/A		EN-GJS-450-10	ASTM 65-45-12	EN-GJS-450-10	ASTM 65-45-12
62A	Base plate	Cast Iron	EN-GJS-450-10	ASTM 65-45-12	EN-GJS-450-10	ASTM 65-45-12	EN-GJS-450-10	ASTM 65-45-12
57	Mechanical seal	Cartridge type						
42	Bottom Bearing ring	SiC / SiC						

SB,SBI,SBN Technical Data



Performance Range

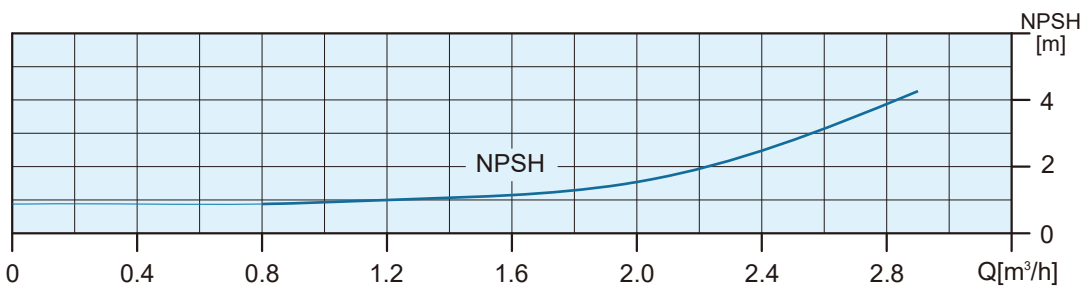
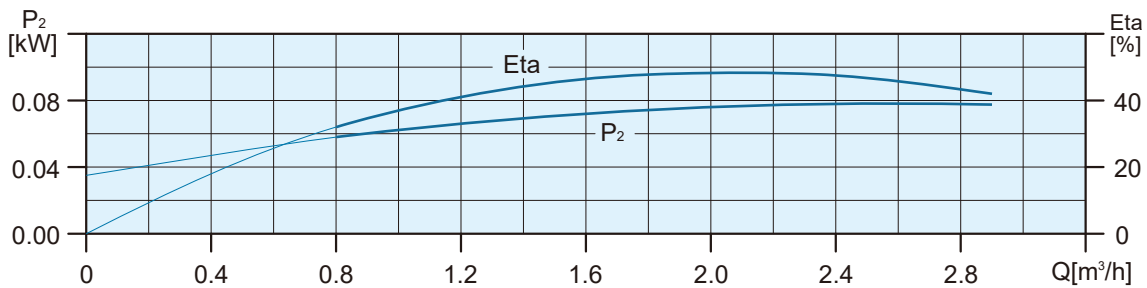
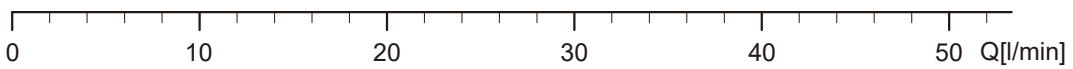
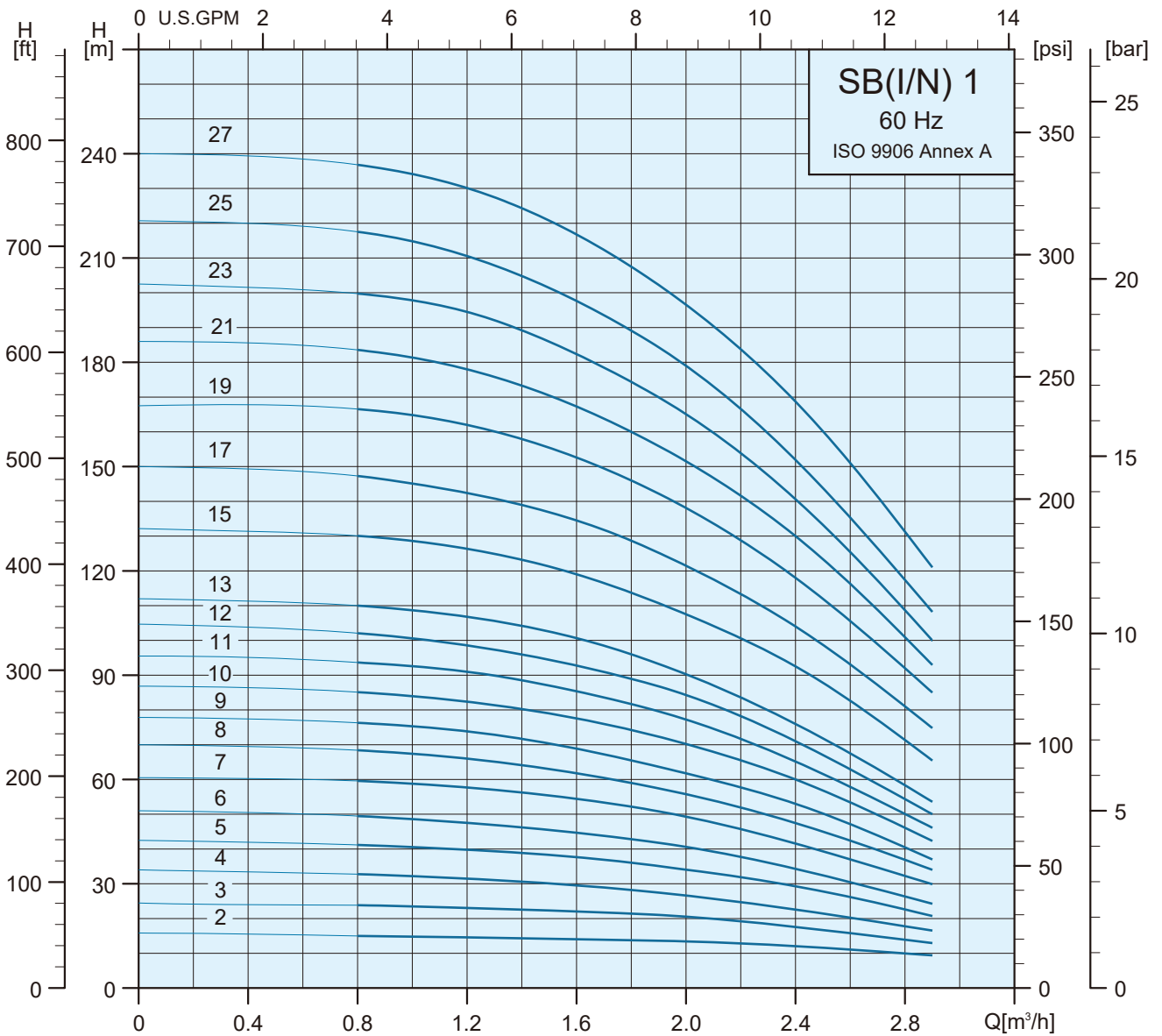

Specifications

Pump Type	Motor		Nominal Current [A]					
	P ₂		1 ϕ		3 ϕ		3 ϕ	
	kW	HP	110V/220V	220-240V	Δ 220-277V	Y380-480V	Δ 380-480V	Y660-830V
SB 1-2	0.37	0.5	6.2 / 3.1	—	1.7 - 1.6	1.0 - 0.9	—	—
SB 1-3	0.37	0.5	6.2 / 3.1	—	1.7 - 1.6	1.0 - 0.9	—	—
SB 1-4	0.37	0.5	6.2 / 3.1	—	1.7 - 1.6	1.0 - 0.9	—	—
SB 1-5	0.55	0.75	8.0 / 4.0	—	2.4 - 2.3	1.4 - 1.3	—	—
SB 1-6	0.55	0.75	8.0 / 4.0	—	2.4 - 2.3	1.4 - 1.3	—	—
SB 1-7	0.75	1.0	8.0 / 4.0	—	3.1 - 3.0	1.8 - 1.7	—	—
SB 1-8	0.75	1.0	10.4 / 5.2	—	3.1 - 3.0	1.8 - 1.7	—	—
SB 1-9	0.75	1.0	10.4 / 5.2	—	3.1 - 3.0	1.8 - 1.7	—	—
SB 1-10	1.1	1.5	—	7.6 - 8.9	4.0 - 3.8	2.3 - 2.2	—	—
SB 1-11	1.1	1.5	—	7.6 - 8.9	4.0 - 3.8	2.3 - 2.2	—	—
SB 1-12	1.1	1.5	—	7.6 - 8.9	4.0 - 3.8	2.3 - 2.2	—	—
SB 1-13	1.1	1.5	—	7.6 - 8.9	4.0 - 3.8	2.3 - 2.2	—	—
SB 1-15	1.5	2.0	—	9.6 - 9.7	5.7 - 5.4	3.3 - 3.1	—	—
SB 1-17	1.5	2.0	—	9.6 - 9.7	5.7 - 5.4	3.3 - 3.1	—	—
SB 1-19	2.2	3.0	—	13.8 - 12.5	8.1 - 7.2	4.7 - 4.2	—	—
SB 1-21	2.2	3.0	—	13.8 - 12.5	8.1 - 7.2	4.7 - 4.2	—	—
SB 1-23	2.2	3.0	—	13.8 - 12.5	8.1 - 7.2	4.7 - 4.2	—	—
SB 1-25	2.2	3.0	—	13.8 - 12.5	8.1 - 7.2	4.7 - 4.2	—	—
SB 1-27	3.0	4.0	—	—	11.1 - 9.7	6.4 - 5.6	6.6 - 5.4	3.8 - 3.1

Dimensions and Weights

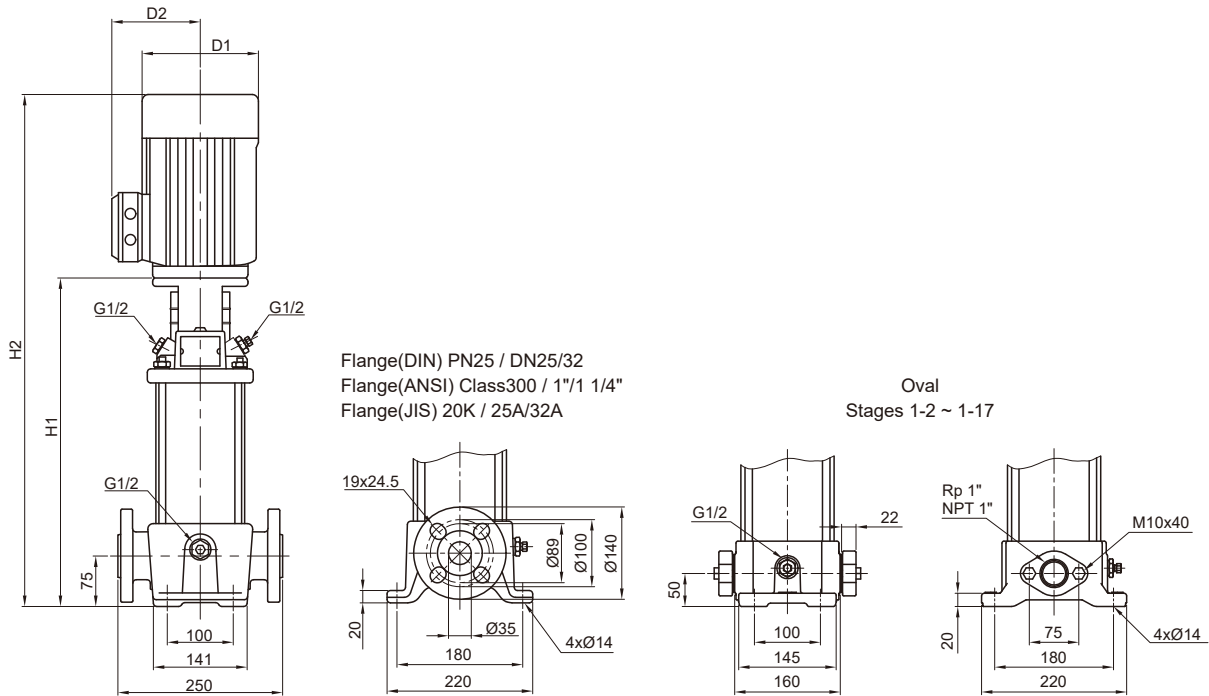

Pump Type	Dimensions (mm)						Net Weight (kg)	
	DIN flange		OVAL		D1	D2	DIN flange	OVAL
	H1	H2	H1	H2				
SB 1-2	279	474	254	449	141	115	23.4	19.3
SB 1-3	279	474	254	449	141	115	23.4	19.3
SB 1-4	297	492	272	467	141	115	23.8	19.7
SB 1-5	315	510	290	485	141	115	24.7	20.6
SB 1-6	333	528	308	503	141	115	25.0	20.9
SB 1-7	357	592	332	567	141	115	27.5	23.4
SB 1-8	375	610	350	585	141	115	27.9	23.8
SB 1-9	393	628	368	603	141	115	28.3	24.2
SB 1-10	411	700	386	675	177	141	35.4	31.3
SB 1-11	429	718	404	693	177	141	35.8	31.7
SB 1-12	447	736	422	711	177	141	36.1	32.0
SB 1-13	465	754	440	729	177	141	36.5	32.4
SB 1-15	517	812	492	787	177	141	41.3	37.2
SB 1-17	553	848	528	823	177	141	42.0	37.9
SB 1-19	589	884	—	—	177	141	44.6	—
SB 1-21	625	920	—	—	177	141	45.3	—
SB 1-23	661	956	—	—	177	141	46.1	—
SB 1-25	697	992	—	—	177	141	46.8	—
SB 1-27	737	1053	—	—	197	147	56.5	—

Performance Range

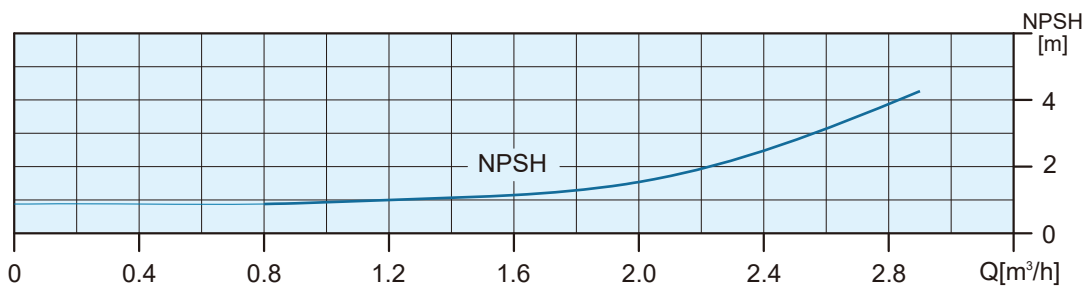
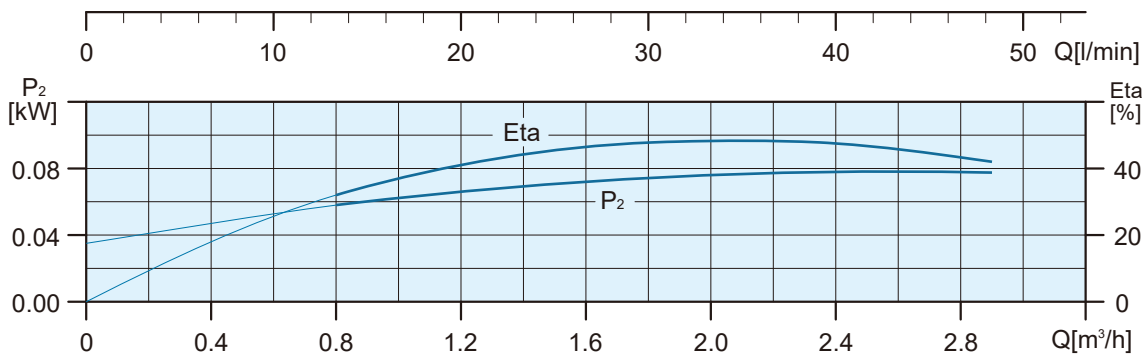
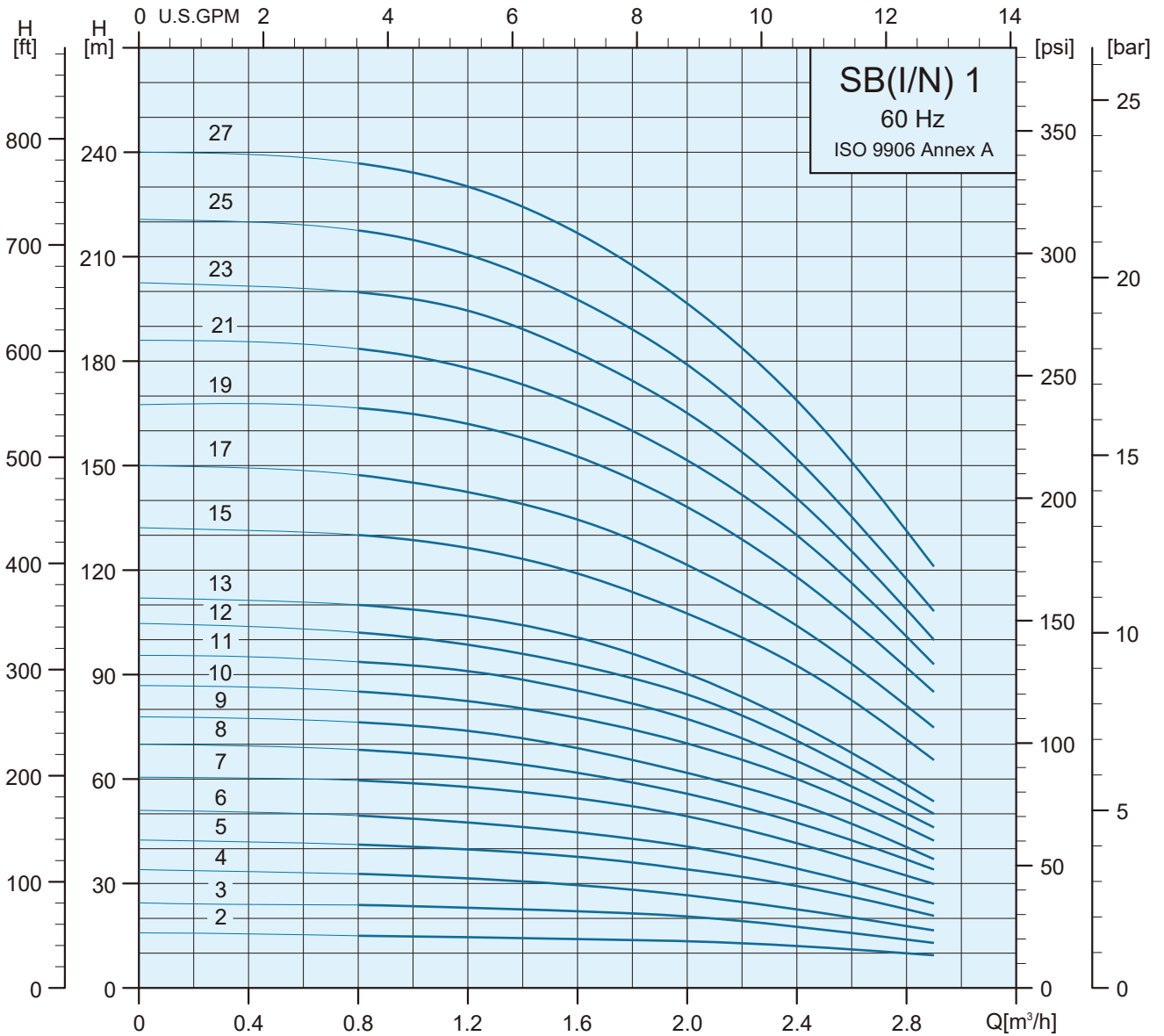

Specifications

Pump Type	Motor		Nominal Current [A]					
	P ₂		1 ϕ		3 ϕ		3 ϕ	
	kW	HP	110V/220V	220-240V	Δ 220-277V	Y380-480V	Δ 380-480V	Y660-830V
SBI(N) 1-2	0.37	0.5	6.2 / 3.1	—	1.7 - 1.6	1.0 - 0.9	—	—
SBI(N) 1-3	0.37	0.5	6.2 / 3.1	—	1.7 - 1.6	1.0 - 0.9	—	—
SBI(N) 1-4	0.37	0.5	6.2 / 3.1	—	1.7 - 1.6	1.0 - 0.9	—	—
SBI(N) 1-5	0.55	0.75	8.0 / 4.0	—	2.4 - 2.3	1.4 - 1.3	—	—
SBI(N) 1-6	0.55	0.75	8.0 / 4.0	—	2.4 - 2.3	1.4 - 1.3	—	—
SBI(N) 1-7	0.75	1.0	8.0 / 4.0	—	3.1 - 3.0	1.8 - 1.7	—	—
SBI(N) 1-8	0.75	1.0	10.4 / 5.2	—	3.1 - 3.0	1.8 - 1.7	—	—
SBI(N) 1-9	0.75	1.0	10.4 / 5.2	—	3.1 - 3.0	1.8 - 1.7	—	—
SBI(N) 1-10	1.1	1.5	—	7.6 - 8.9	4.0 - 3.8	2.3 - 2.2	—	—
SBI(N) 1-11	1.1	1.5	—	7.6 - 8.9	4.0 - 3.8	2.3 - 2.2	—	—
SBI(N) 1-12	1.1	1.5	—	7.6 - 8.9	4.0 - 3.8	2.3 - 2.2	—	—
SBI(N) 1-13	1.1	1.5	—	7.6 - 8.9	4.0 - 3.8	2.3 - 2.2	—	—
SBI(N) 1-15	1.5	2.0	—	9.6 - 9.7	5.7 - 5.4	3.3 - 3.1	—	—
SBI(N)1-17	1.5	2.0	—	9.6 - 9.7	5.7 - 5.4	3.3 - 3.1	—	—
SBI(N) 1-19	2.2	3.0	—	13.8 - 12.5	8.1 - 7.2	4.7 - 4.2	—	—
SBI(N) 1-21	2.2	3.0	—	13.8 - 12.5	8.1 - 7.2	4.7 - 4.2	—	—
SBI(N) 1-23	2.2	3.0	—	13.8 - 12.5	8.1 - 7.2	4.7 - 4.2	—	—
SBI(N) 1-25	2.2	3.0	—	13.8 - 12.5	8.1 - 7.2	4.7 - 4.2	—	—
SBI(N) 1-27	3.0	4.0	—	—	11.1 - 9.7	6.4 - 5.6	6.6 - 5.4	3.8 - 3.1

Dimensions and Weights

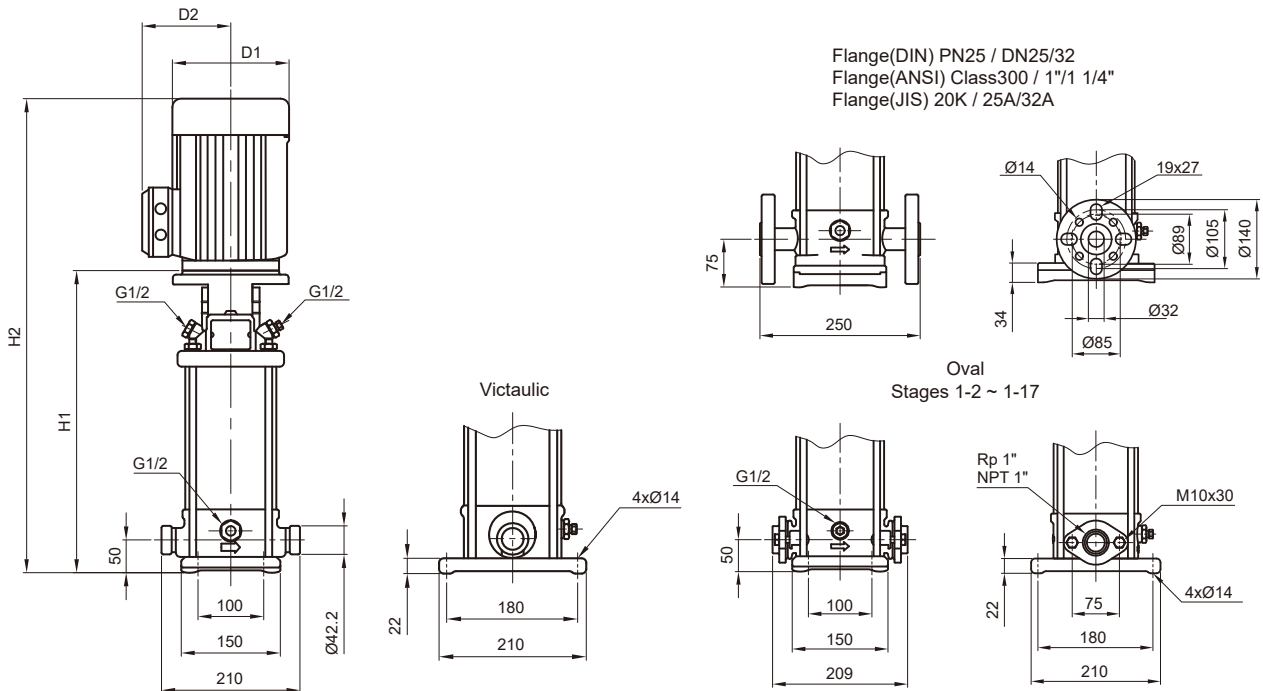

Pump Type	Dimensions (mm)								Net Weight (kg)		
	Victaulic		DIN flange		OVAL		D1	D2	Victaulic	DIN flange	OVAL
	H1	H2	H1	H2	H1	H2					
SBI(N) 1-2	257	452	282	477	257	452	141	115	19.3	20.2	17.1
SBI(N) 1-3	257	452	282	477	257	452	141	115	19.3	20.3	17.1
SBI(N) 1-4	275	470	300	495	275	470	141	115	19.7	20.6	17.5
SBI(N) 1-5	293	488	318	513	293	488	141	115	20.6	21.5	18.4
SBI(N) 1-6	311	506	336	531	311	506	141	115	20.9	21.9	18.7
SBI(N) 1-7	335	570	360	595	335	570	141	115	23.3	24.2	21.1
SBI(N) 1-8	353	588	378	613	353	588	141	115	23.7	24.6	21.5
SBI(N) 1-9	371	606	396	631	371	606	141	115	24.0	25.0	21.9
SBI(N) 1-10	389	678	414	703	389	678	177	141	31.1	32.1	29.0
SBI(N) 1-11	407	696	432	721	407	696	177	141	31.5	32.5	29.4
SBI(N) 1-12	425	714	450	739	425	714	177	141	31.9	32.8	29.7
SBI(N) 1-13	443	732	468	757	443	732	177	141	32.3	33.2	30.1
SBI(N) 1-15	495	790	520	815	495	790	177	141	37.1	38.1	35.0
SBI(N) 1-17	531	826	556	851	531	826	177	141	37.9	38.8	35.7
SBI(N) 1-19	567	862	592	887	—	—	177	141	40.4	41.3	—
SBI(N) 1-21	603	898	628	923	—	—	177	141	41.2	42.1	—
SBI(N) 1-23	639	934	664	959	—	—	177	141	41.9	42.9	—
SBI(N) 1-25	675	970	700	995	—	—	177	141	42.6	43.6	—
SBI(N) 1-27	716	1032	741	1057	—	—	197	147	51.9	52.9	—

Performance Range

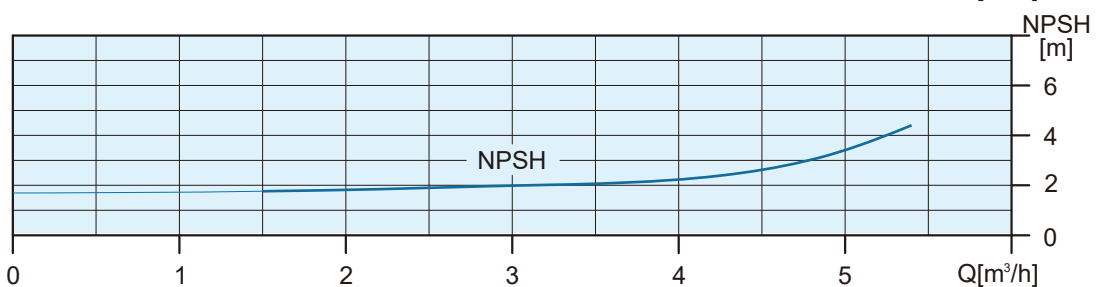
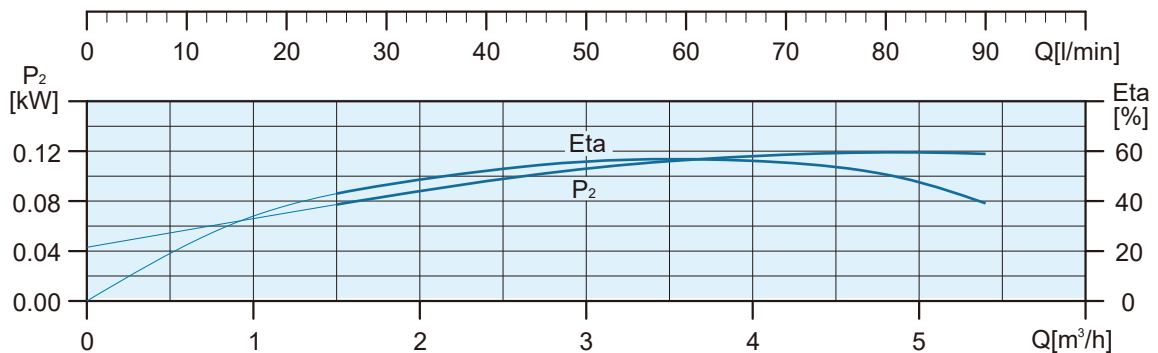
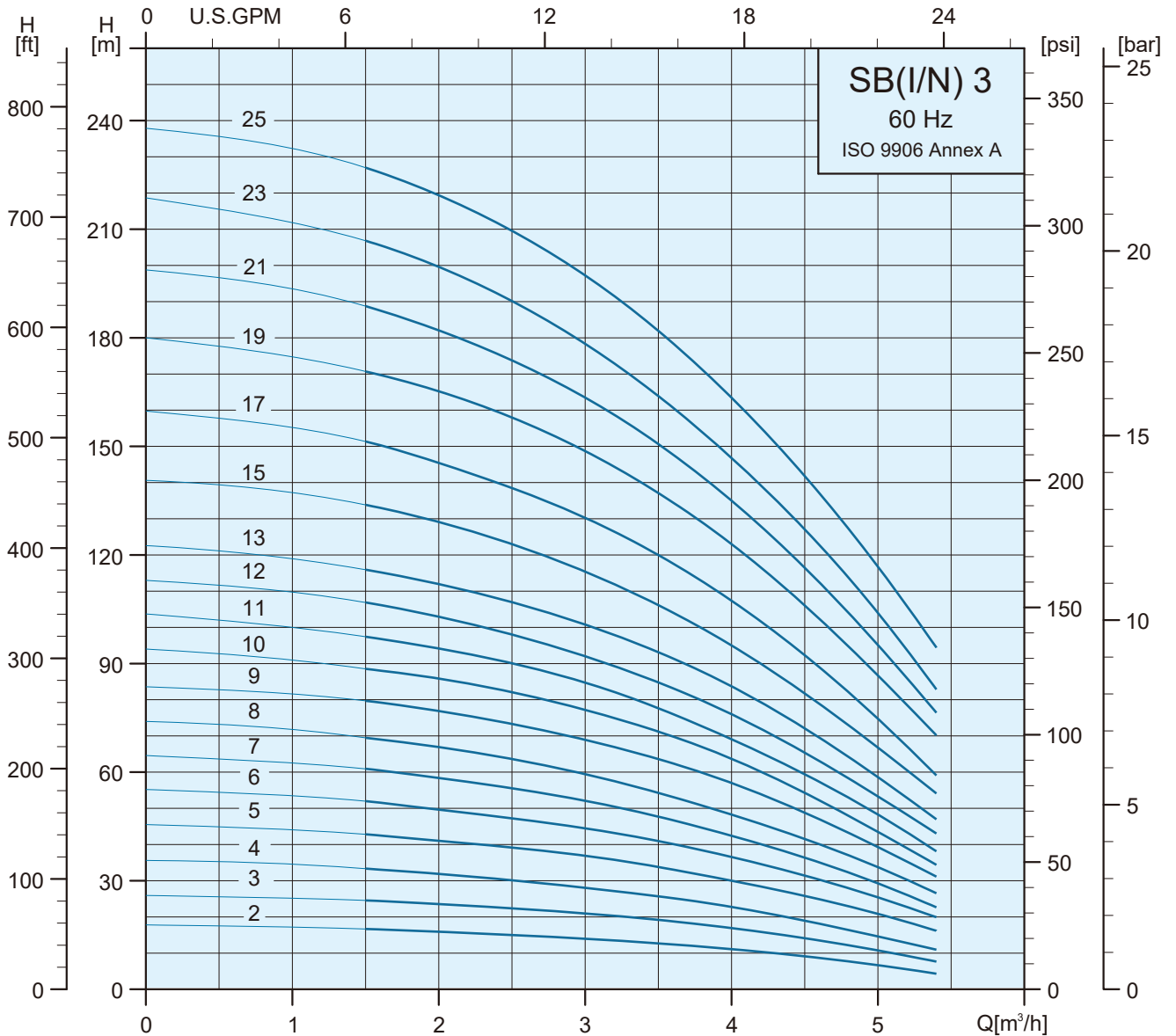

Specifications

Pump Type	Motor		Nominal Current [A]					
	P ₂		1φ		3φ		3φ	
	kW	HP	110V/220V	220-240V	△220-277V	Y380-480V	△380-480V	Y660-830V
SB 3-2	0.37	0.5	6.2 / 3.1	—	1.7 - 1.6	1.0 - 0.9	—	—
SB 3-3	0.55	0.75	8.0 / 4.0	—	2.4 - 2.3	1.4 - 1.3	—	—
SB 3-4	0.55	0.75	8.0 / 4.0	—	2.4 - 2.3	1.4 - 1.3	—	—
SB 3-5	0.75	1.0	10.4 / 5.2	—	3.1 - 3.0	1.8 - 1.7	—	—
SB 3-6	1.1	1.5	—	7.6 - 8.9	4.0 - 3.8	2.3 - 2.2	—	—
SB 3-7	1.1	1.5	—	7.6 - 8.9	4.0 - 3.8	2.3 - 2.2	—	—
SB 3-8	1.1	1.5	—	7.6 - 8.9	4.0 - 3.8	2.3 - 2.2	—	—
SB 3-9	1.5	2.0	—	9.6 - 9.7	5.7 - 5.4	3.3 - 3.1	—	—
SB 3-10	1.5	2.0	—	9.6 - 9.7	5.7 - 5.4	3.3 - 3.1	—	—
SB 3-11	1.5	2.0	—	9.6 - 9.7	5.7 - 5.4	3.3 - 3.1	—	—
SB 3-12	2.2	3.0	—	13.8 - 12.5	8.1 - 7.2	4.7 - 4.2	—	—
SB 3-13	2.2	3.0	—	13.8 - 12.5	8.1 - 7.2	4.7 - 4.2	—	—
SB 3-15	2.2	3.0	—	13.8 - 12.5	8.1 - 7.2	4.7 - 4.2	—	—
SB 3-17	2.2	3.0	—	13.8 - 12.5	8.1 - 7.2	4.7 - 4.2	—	—
SB 3-19	3.0	4.0	—	—	11.1 - 9.7	6.4 - 5.6	6.6 - 5.4	3.8 - 3.1
SB 3-21	3.0	4.0	—	—	11.1 - 9.7	6.4 - 5.6	6.6 - 5.4	3.8 - 3.1
SB 3-23	3.0	4.0	—	—	11.1 - 9.7	6.4 - 5.6	6.6 - 5.4	3.8 - 3.1
SB 3-25	4.0	5.5	—	—	14.3 - 13.1	8.3 - 7.6	8.2 - 7.0	4.7 - 4.0

Dimensions and Weights

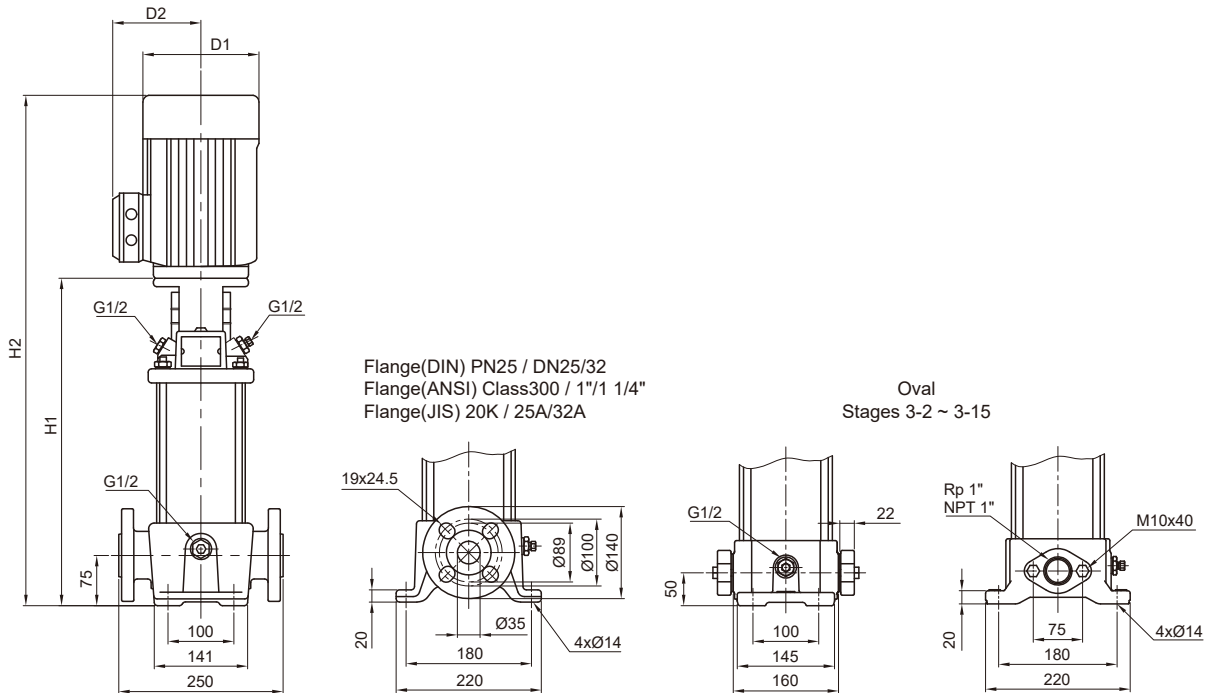

Pump Type	Dimensions (mm)						Net Weight (kg)	
	DIN flange		OVAL		D1	D2	DIN flange	OVAL
	H1	H2	H1	H2				
SB 3-2	279	474	254	449	141	115	23.4	19.3
SB 3-3	279	474	254	449	141	115	23.9	19.8
SB 3-4	297	492	272	467	141	115	24.3	20.2
SB 3-5	321	556	296	531	141	115	26.8	22.7
SB 3-6	339	628	314	603	177	141	33.9	29.8
SB 3-7	357	646	332	621	177	141	34.3	30.2
SB 3-8	375	664	350	639	177	141	34.6	30.5
SB 3-9	409	704	384	679	177	141	39.1	35.0
SB 3-10	427	722	402	697	177	141	39.5	35.4
SB 3-11	445	740	420	715	177	141	39.9	35.8
SB 3-12	463	758	438	733	177	141	42.0	37.9
SB 3-13	481	776	456	751	177	141	42.4	38.3
SB 3-15	517	812	492	787	177	141	43.1	39.0
SB 3-17	553	848	—	—	177	141	43.8	—
SB 3-19	593	909	—	—	197	147	53.5	—
SB 3-21	629	945	—	—	197	147	53.9	—
SB 3-23	665	981	—	—	197	147	55.0	—
SB 3-25	701	1027	—	—	220	161	59.7	—

Performance Range

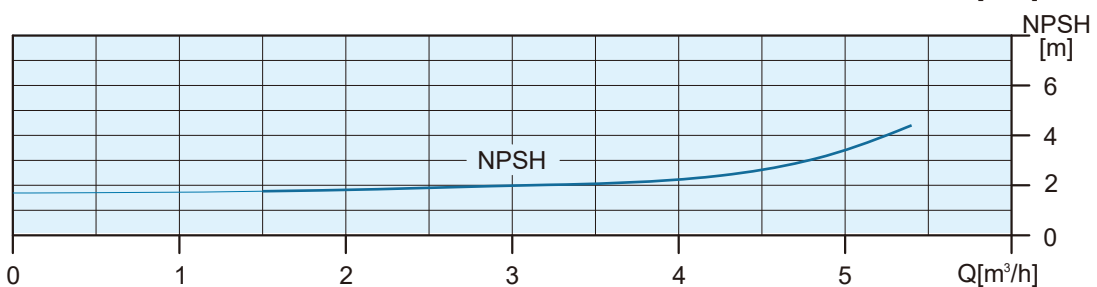
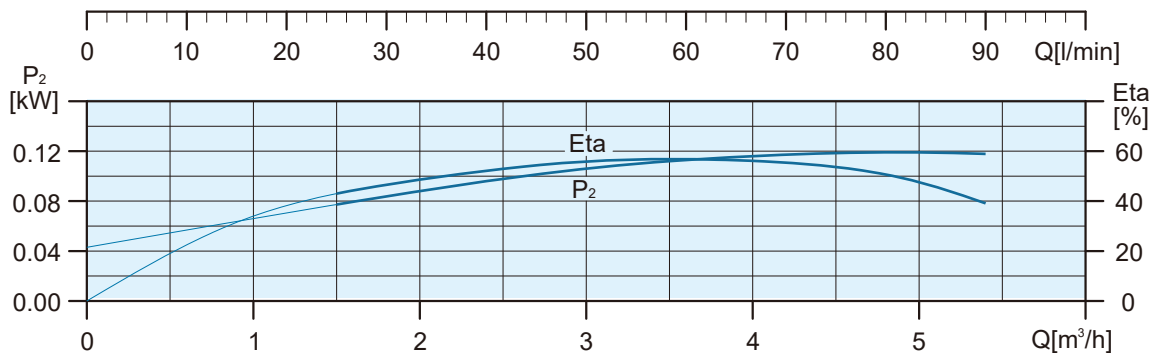
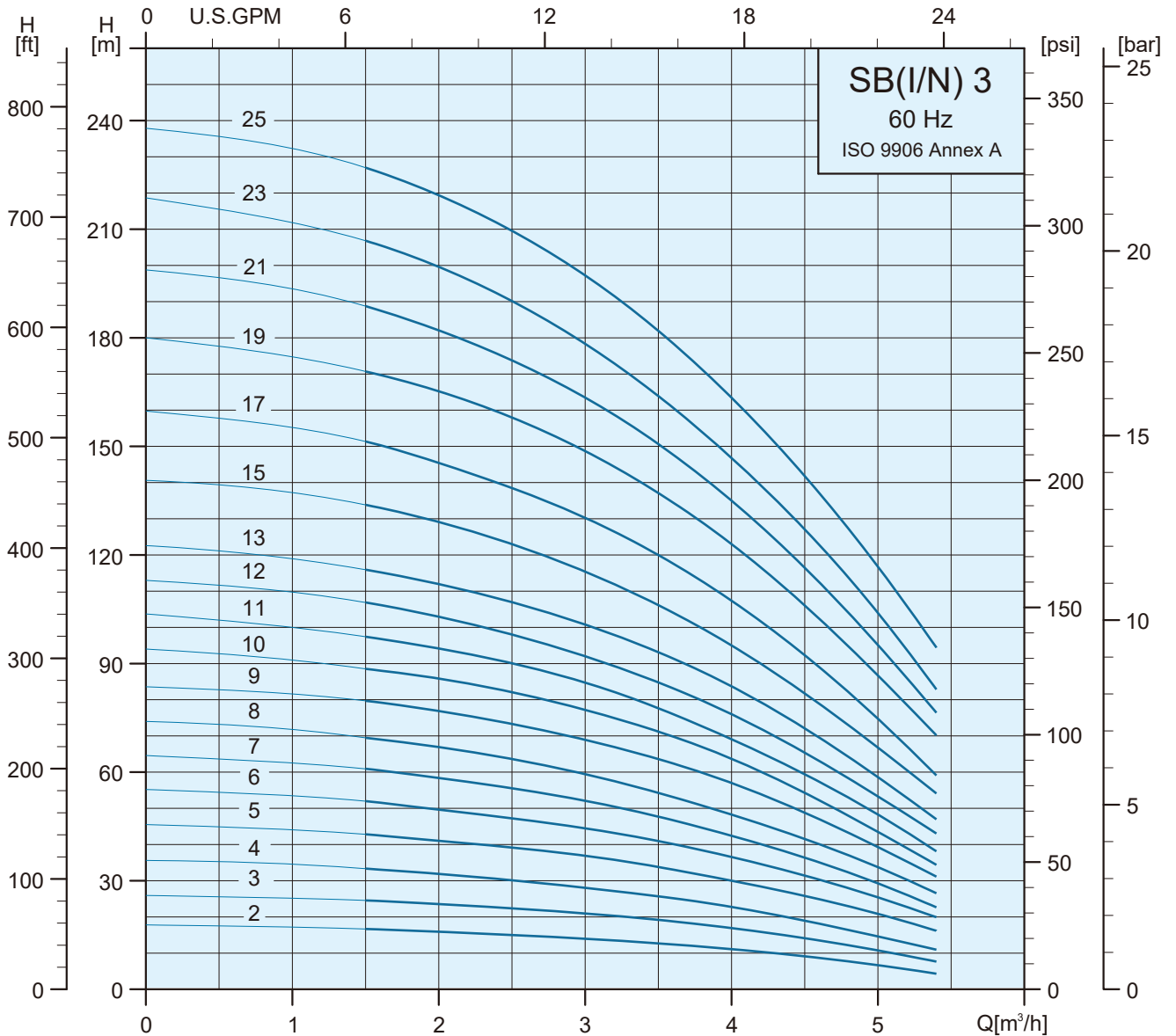

Specifications

Pump Type	Motor		Nominal Current [A]					
	P ₂		1φ		3φ		3φ	
	kW	HP	110V/220V	220-240V	Δ220-277V	Y380-480V	Δ380-480V	Y660-830V
SBI(N) 3-2	0.37	0.5	6.2 / 3.1	—	1.7 - 1.6	1.0 - 0.9	—	—
SBI(N) 3-3	0.55	0.75	8.0 / 4.0	—	2.4 - 2.3	1.4 - 1.3	—	—
SBI(N) 3-4	0.55	0.75	8.0 / 4.0	—	2.4 - 2.3	1.4 - 1.3	—	—
SBI(N) 3-5	0.75	1.0	10.4 / 5.2	—	3.1 - 3.0	1.8 - 1.7	—	—
SBI(N) 3-6	1.1	1.5	—	7.6 - 8.9	4.0 - 3.8	2.3 - 2.2	—	—
SBI(N) 3-7	1.1	1.5	—	7.6 - 8.9	4.0 - 3.8	2.3 - 2.2	—	—
SBI(N) 3-8	1.1	1.5	—	7.6 - 8.9	4.0 - 3.8	2.3 - 2.2	—	—
SBI(N) 3-9	1.5	2.0	—	9.6 - 9.7	5.7 - 5.4	3.3 - 3.1	—	—
SBI(N) 3-10	1.5	2.0	—	9.6 - 9.7	5.7 - 5.4	3.3 - 3.1	—	—
SBI(N) 3-11	1.5	2.0	—	9.6 - 9.7	5.7 - 5.4	3.3 - 3.1	—	—
SBI(N) 3-12	2.2	3.0	—	13.8 - 12.5	8.1 - 7.2	4.7 - 4.2	—	—
SBI(N) 3-13	2.2	3.0	—	13.8 - 12.5	8.1 - 7.2	4.7 - 4.2	—	—
SBI(N) 3-15	2.2	3.0	—	13.8 - 12.5	8.1 - 7.2	4.7 - 4.2	—	—
SBI(N) 3-17	2.2	3.0	—	13.8 - 12.5	8.1 - 7.2	4.7 - 4.2	—	—
SBI(N) 3-19	3.0	4.0	—	—	11.1 - 9.7	6.4 - 5.6	6.6 - 5.4	3.8 - 3.1
SBI(N) 3-21	3.0	4.0	—	—	11.1 - 9.7	6.4 - 5.6	6.6 - 5.4	3.8 - 3.1
SBI(N) 3-23	3.0	4.0	—	—	11.1 - 9.7	6.4 - 5.6	6.6 - 5.4	3.8 - 3.1
SBI(N) 3-25	4.0	5.5	—	—	14.3 - 13.1	8.3 - 7.6	8.2 - 7.0	4.7 - 4.0

Dimensions and Weights

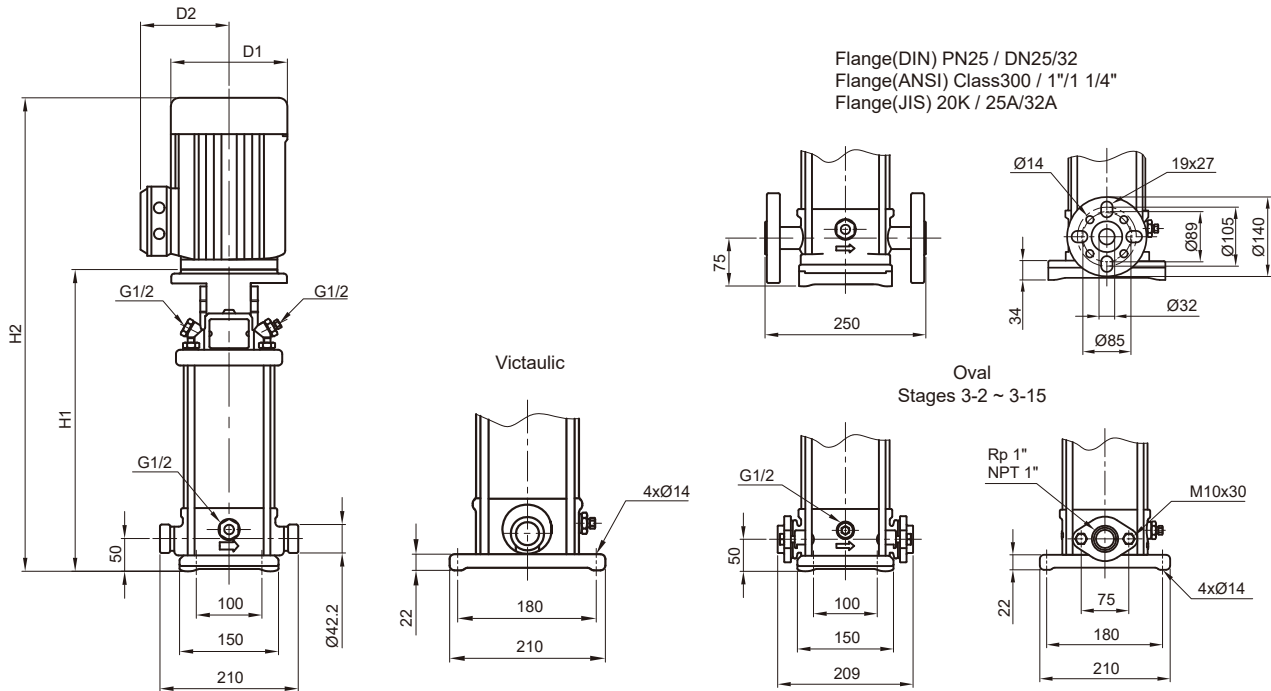

Pump Type	Dimensions (mm)						Net Weight (kg)				
	Victaulic		DIN flange		OVAL		D1	D2	Victaulic	DIN flange	OVAL
	H1	H2	H1	H2	H1	H2					
SBI(N) 3-2	257	452	282	477	257	452	141	115	19.3	20.2	17.1
SBI(N) 3-3	257	452	282	477	257	452	141	115	19.8	20.8	17.6
SBI(N) 3-4	275	470	300	495	275	470	141	115	20.2	21.1	18.0
SBI(N) 3-5	299	534	324	559	299	534	141	115	22.6	23.5	20.4
SBI(N) 3-6	317	606	342	631	317	606	177	141	29.7	30.6	27.5
SBI(N) 3-7	335	624	360	649	335	624	177	141	30.0	31.0	27.9
SBI(N) 3-8	353	642	378	667	353	642	177	141	30.4	31.3	28.2
SBI(N) 3-9	387	682	412	707	387	682	177	141	34.9	35.9	32.8
SBI(N) 3-10	405	700	430	725	405	700	177	141	35.3	36.2	33.1
SBI(N) 3-11	423	718	448	743	423	718	177	141	35.7	36.5	33.4
SBI(N) 3-12	441	736	466	761	441	736	177	141	37.9	38.8	35.7
SBI(N) 3-13	459	754	484	779	459	754	177	141	38.3	39.2	36.1
SBI(N) 3-15	495	790	520	815	495	790	177	141	38.9	39.9	36.8
SBI(N) 3-17	531	826	556	851	—	—	177	141	39.7	40.6	—
SBI(N) 3-19	572	888	597	913	—	—	197	147	49.0	49.9	—
SBI(N) 3-21	608	924	633	949	—	—	197	147	49.7	50.7	—
SBI(N) 3-23	644	960	669	985	—	—	197	147	50.5	51.4	—
SBI(N) 3-25	680	1006	705	1031	—	—	220	161	55.2	56.1	—

Performance Range

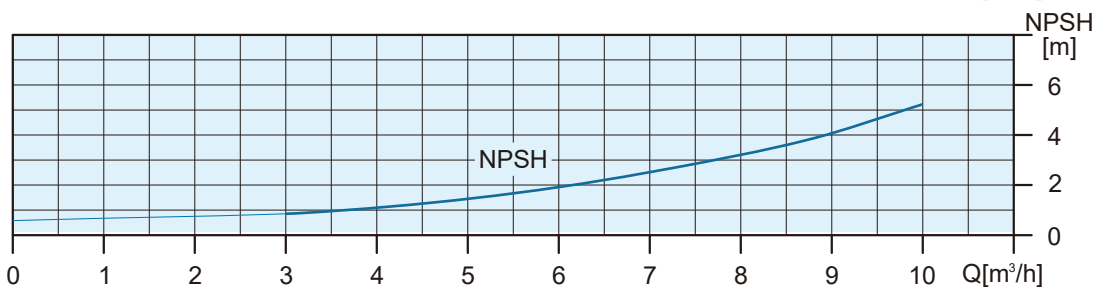
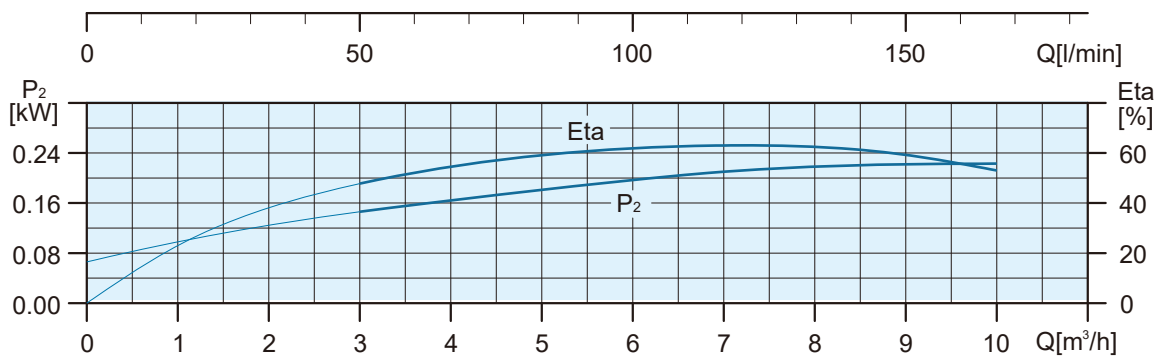
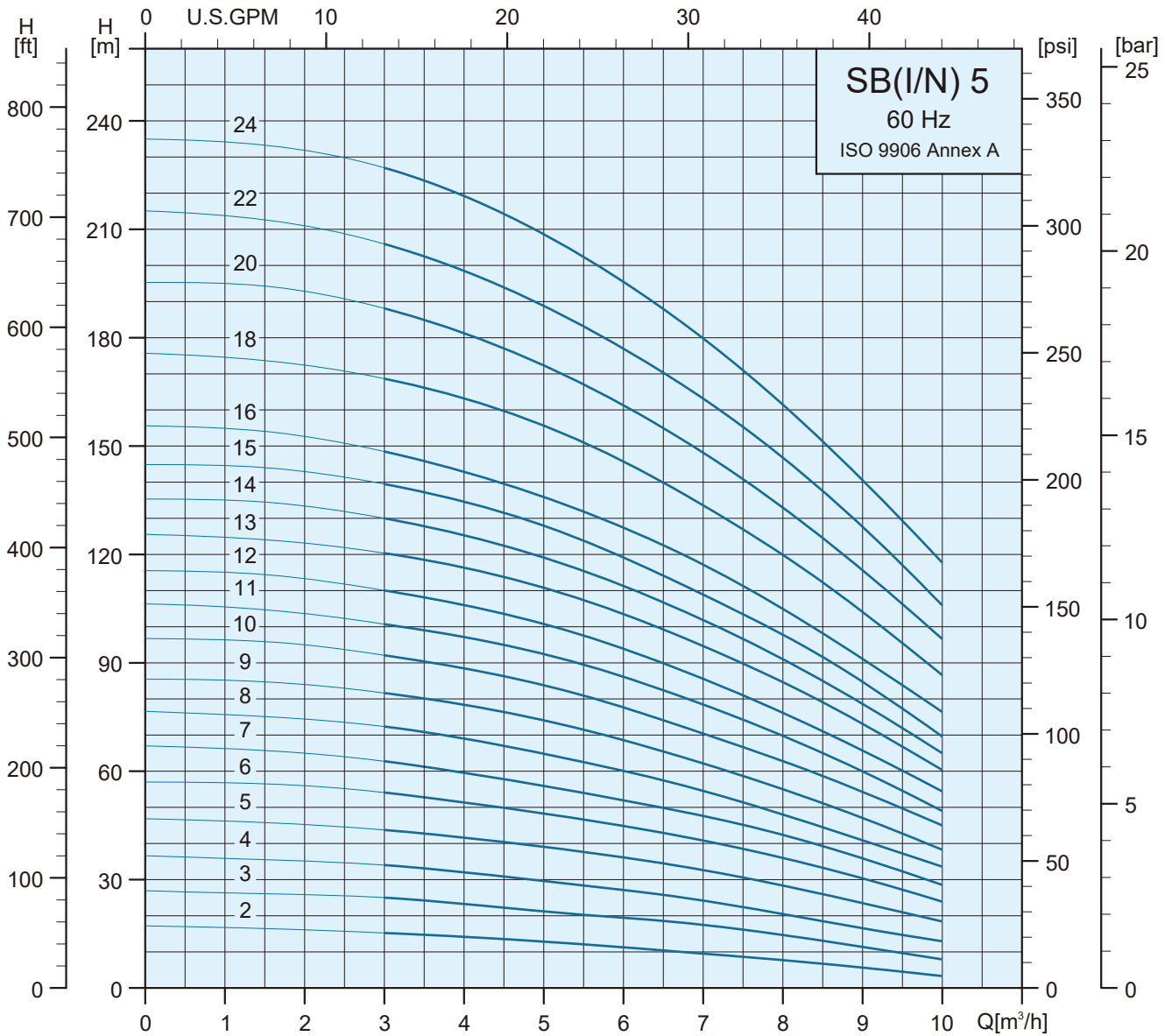

Specifications

Pump Type	Motor		Nominal Current [A]					
	P ₂		1 ϕ		3 ϕ		3 ϕ	
	kW	HP	110V/220V	220-240V	Δ 220-277V	Y380-480V	Δ 380-480V	Y660-830V
SB 5-2	0.55	0.75	8.0 / 4.0	—	2.4 - 2.3	1.4 - 1.3	—	—
SB 5-3	1.1	1.5	—	7.6 - 8.9	4.0 - 3.8	2.3 - 2.2	—	—
SB 5-4	1.1	1.5	—	7.6 - 8.9	4.0 - 3.8	2.3 - 2.2	—	—
SB 5-5	1.5	2.0	—	9.6 - 9.7	5.7 - 5.4	3.3 - 3.1	—	—
SB 5-6	2.2	3.0	—	13.8 - 12.5	8.1 - 7.2	4.7 - 4.2	—	—
SB 5-7	2.2	3.0	—	13.8 - 12.5	8.1 - 7.2	4.7 - 4.2	—	—
SB 5-8	2.2	3.0	—	13.8 - 12.5	8.1 - 7.2	4.7 - 4.2	—	—
SB 5-9	2.2	3.0	—	13.8 - 12.5	8.1 - 7.2	4.7 - 4.2	—	—
SB 5-10	3.0	4.0	—	—	11.1 - 9.7	6.4 - 5.6	6.6 - 5.4	3.8 - 3.1
SB 5-11	3.0	4.0	—	—	11.1 - 9.7	6.4 - 5.6	6.6 - 5.4	3.8 - 3.1
SB 5-12	3.0	4.0	—	—	11.1 - 9.7	6.4 - 5.6	6.6 - 5.4	3.8 - 3.1
SB 5-13	4.0	5.5	—	—	14.3 - 13.1	8.3 - 7.6	8.2 - 7.0	4.7 - 4.0
SB 5-14	4.0	5.5	—	—	14.3 - 13.1	8.3 - 7.6	8.2 - 7.0	4.7 - 4.0
SB 5-15	4.0	5.5	—	—	14.3 - 13.1	8.3 - 7.6	8.2 - 7.0	4.7 - 4.0
SB 5-16	4.0	5.5	—	—	14.3 - 13.1	8.3 - 7.6	8.2 - 7.0	4.7 - 4.0
SB 5-18	5.5	7.5	—	—	19.2 - 16.9	11.1 - 9.8	11.2 - 9.6	6.5 - 5.5
SB 5-20	5.5	7.5	—	—	19.2 - 16.9	11.1 - 9.8	11.2 - 9.6	6.5 - 5.5
SB 5-22	5.5	7.5	—	—	19.2 - 16.9	11.1 - 9.8	11.2 - 9.6	6.5 - 5.5
SB 5-24	7.5	10.0	—	—	25.4 - 22.1	14.7 - 12.8	14.9 - 13.3	8.6 - 7.7

Dimensions and Weights

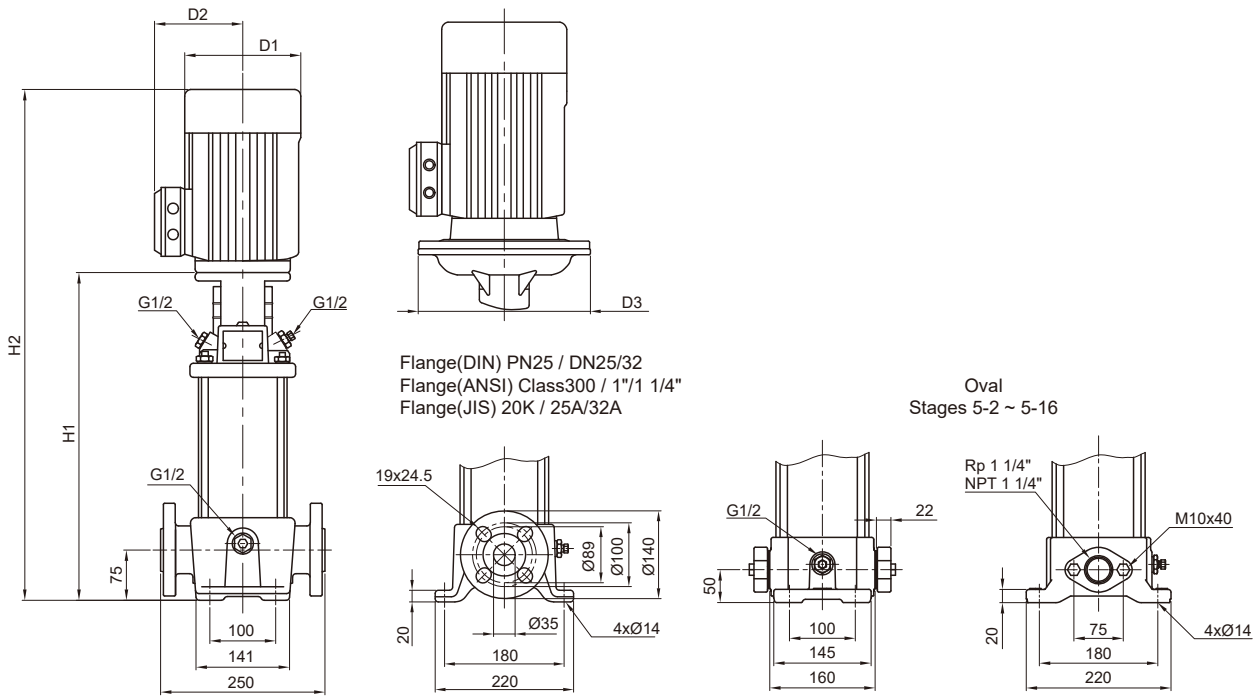

Pump Type	Dimensions (mm)							Net Weight (kg)	
	DIN flange		OVAL		D1	D2	D3	DIN flange	OVAL
	H1	H2	H1	H2					
SB 5-2	279	474	254	449	141	115	—	23.8	19.5
SB 5-3	312	601	287	576	177	141	—	33.1	28.8
SB 5-4	339	628	314	603	177	141	—	33.6	29.3
SB 5-5	382	677	357	652	177	141	—	38.2	33.9
SB 5-6	409	704	384	679	177	141	—	40.6	36.3
SB 5-7	436	731	411	706	177	141	—	41.1	36.8
SB 5-8	463	758	438	733	177	141	—	41.6	37.3
SB 5-9	490	785	465	760	177	141	—	42.1	37.8
SB 5-10	521	837	496	812	197	147	—	51.6	47.3
SB 5-11	548	864	523	839	197	147	—	52.1	47.8
SB 5-12	575	891	550	866	197	147	—	52.6	48.3
SB 5-13	602	928	577	903	220	161	—	57.1	52.8
SB 5-14	629	955	604	930	220	161	—	57.7	53.4
SB 5-15	656	982	631	957	220	161	—	58.1	53.8
SB 5-16	683	1009	658	984	220	161	—	58.7	54.4
SB 5-18	767	1129	—	—	235	197	300	80.6	—
SB 5-20	821	1183	—	—	235	197	300	81.8	—
SB 5-22	875	1237	—	—	235	197	300	82.7	—
SB 5-24	929	1334	—	—	235	197	300	89.6	—

Performance Range

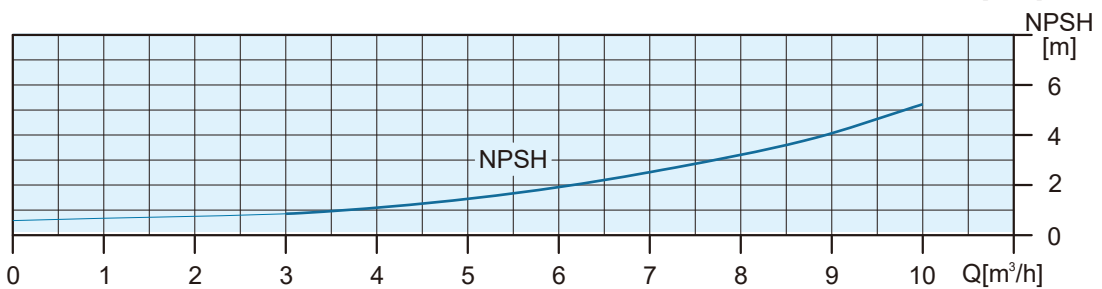
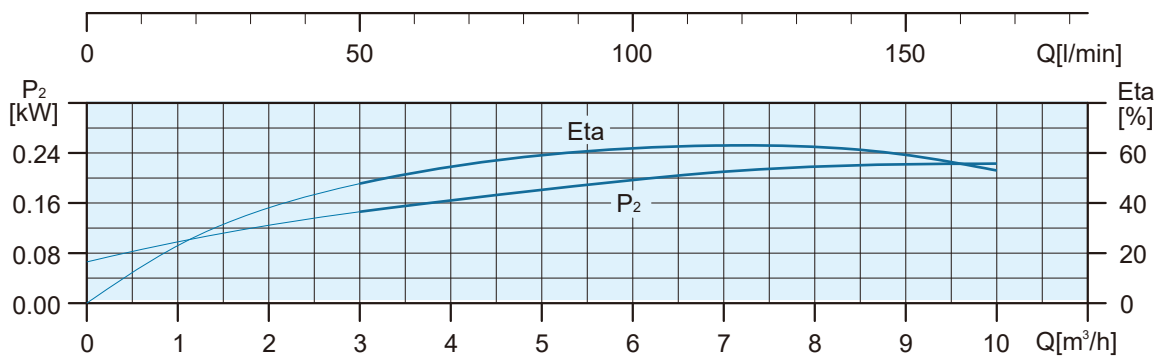
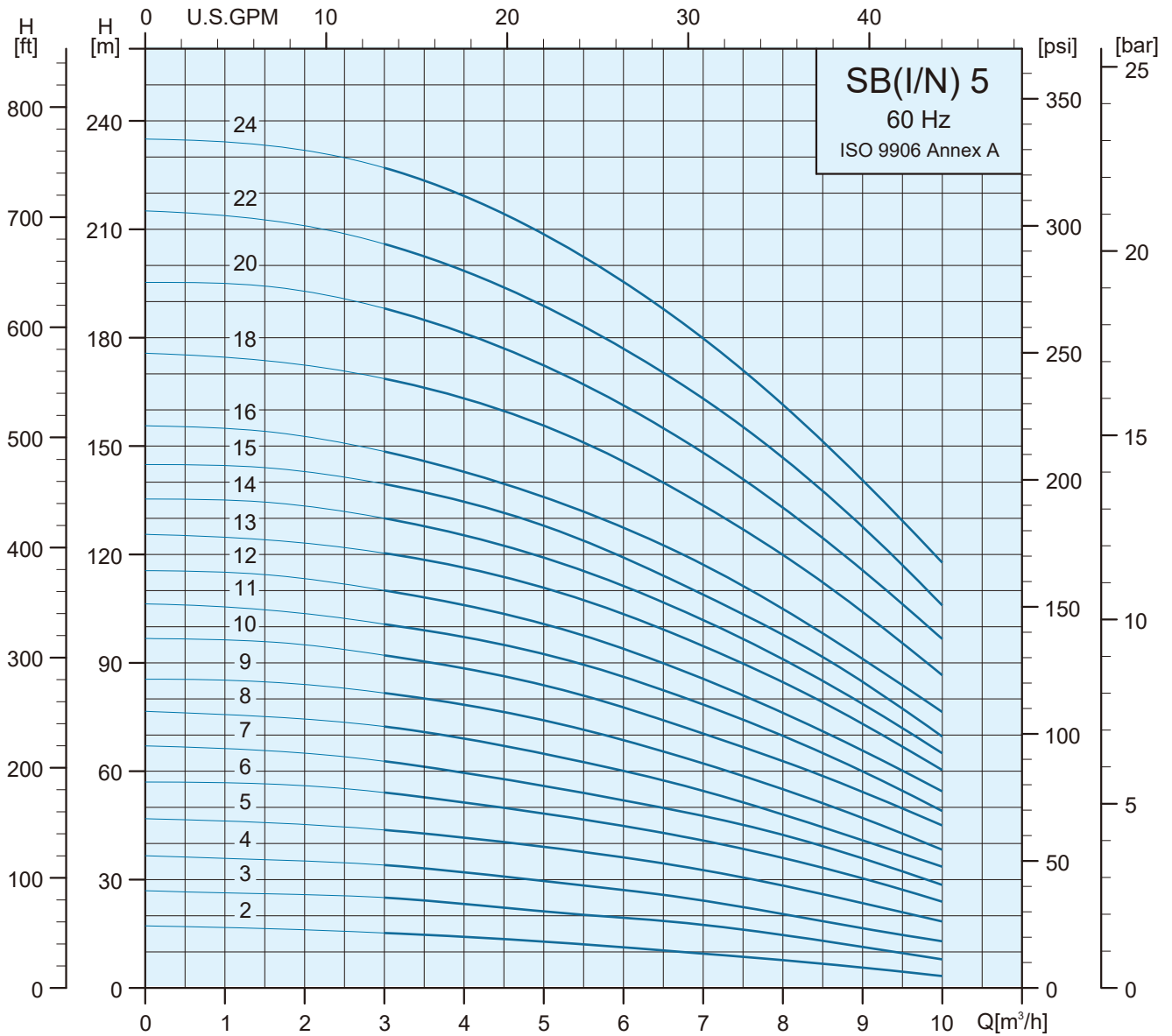

Specifications

Pump Type	Motor		Nominal Current [A]					
	P ₂		1φ		3φ		3φ	
	kW	HP	110V/220V	220-240V	Δ220-277V	Y380-480V	Δ380-480V	Y660-830V
SBI(N) 5-2	0.55	0.75	8.0 / 4.0	—	2.4 - 2.3	1.4 - 1.3	—	—
SBI(N) 5-3	1.1	1.5	—	7.6 - 8.9	4.0 - 3.8	2.3 - 2.2	—	—
SBI(N) 5-4	1.1	1.5	—	7.6 - 8.9	4.0 - 3.8	2.3 - 2.2	—	—
SBI(N) 5-5	1.5	2.0	—	9.6 - 9.7	5.7 - 5.4	3.3 - 3.1	—	—
SBI(N) 5-6	2.2	3.0	—	13.8 - 12.5	8.1 - 7.2	4.7 - 4.2	—	—
SBI(N) 5-7	2.2	3.0	—	13.8 - 12.5	8.1 - 7.2	4.7 - 4.2	—	—
SBI(N) 5-8	2.2	3.0	—	13.8 - 12.5	8.1 - 7.2	4.7 - 4.2	—	—
SBI(N) 5-9	2.2	3.0	—	13.8 - 12.5	8.1 - 7.2	4.7 - 4.2	—	—
SBI(N) 5-10	3.0	4.0	—	—	11.1 - 9.7	6.4 - 5.6	6.6 - 5.4	3.8 - 3.1
SBI(N) 5-11	3.0	4.0	—	—	11.1 - 9.7	6.4 - 5.6	6.6 - 5.4	3.8 - 3.1
SBI(N) 5-12	3.0	4.0	—	—	11.1 - 9.7	6.4 - 5.6	6.6 - 5.4	3.8 - 3.1
SBI(N) 5-13	4.0	5.5	—	—	14.3 - 13.1	8.3 - 7.6	8.2 - 7.0	4.7 - 4.0
SBI(N) 5-14	4.0	5.5	—	—	14.3 - 13.1	8.3 - 7.6	8.2 - 7.0	4.7 - 4.0
SBI(N) 5-15	4.0	5.5	—	—	14.3 - 13.1	8.3 - 7.6	8.2 - 7.0	4.7 - 4.0
SBI(N) 5-16	4.0	5.5	—	—	14.3 - 13.1	8.3 - 7.6	8.2 - 7.0	4.7 - 4.0
SBI(N) 5-18	5.5	7.5	—	—	19.2 - 16.9	11.1 - 9.8	11.2 - 9.6	6.5 - 5.5
SBI(N) 5-20	5.5	7.5	—	—	19.2 - 16.9	11.1 - 9.8	11.2 - 9.6	6.5 - 5.5
SBI(N) 5-22	5.5	7.5	—	—	19.2 - 16.9	11.1 - 9.8	11.2 - 9.6	6.5 - 5.5
SBI(N) 5-24	7.5	10.0	—	—	25.4 - 22.1	14.7 - 12.8	14.9 - 13.3	8.6 - 7.7

Dimensions and Weights

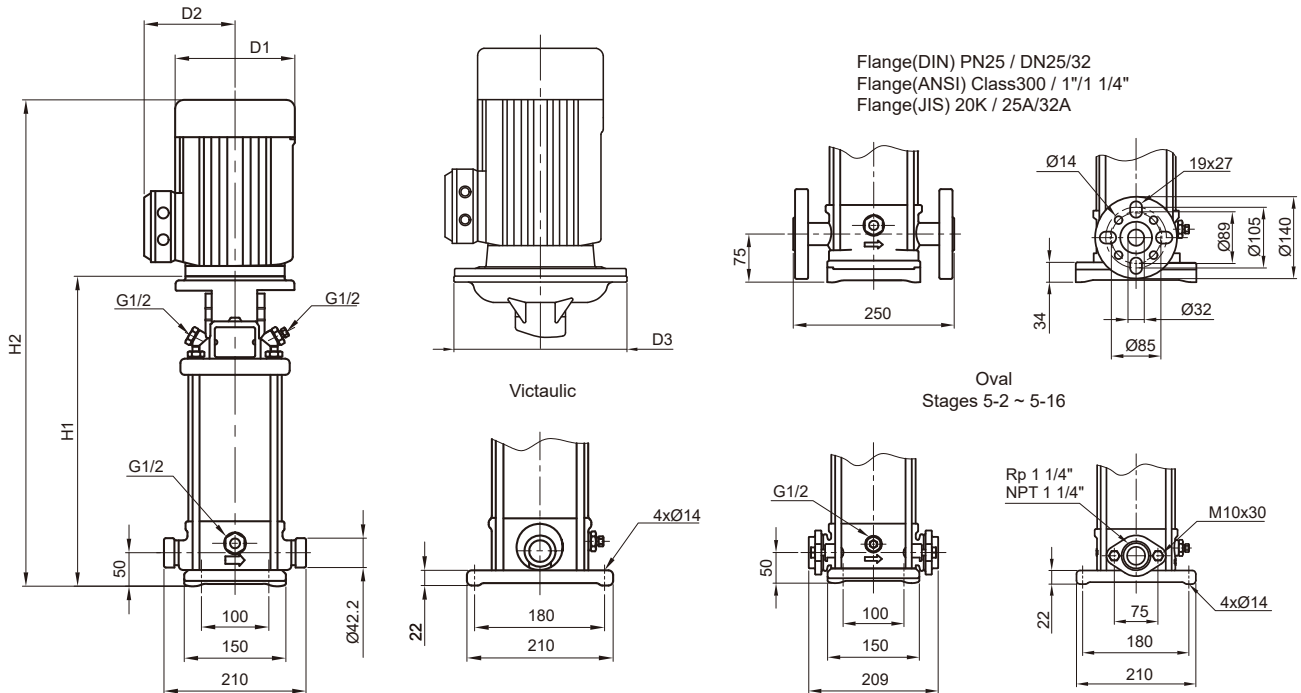

Pump Type	Dimensions (mm)									Net Weight (kg)		
	Victaulic		DIN flange		OVAL		D1	D2	D3	Victaulic	DIN flange	OVAL
	H1	H2	H1	H2	H1	H2						
SBI(N) 5-2	257	452	282	477	257	452	141	115	—	19.7	20.6	17.4
SBI(N) 5-3	290	579	315	604	290	579	177	141	—	29.0	30.0	26.8
SBI(N) 5-4	317	606	342	631	317	606	177	141	—	29.6	30.5	27.3
SBI(N) 5-5	360	655	385	680	360	655	177	141	—	34.3	35.3	32.1
SBI(N) 5-6	387	682	412	707	387	682	177	141	—	36.6	37.6	34.4
SBI(N) 5-7	414	709	439	734	414	709	177	141	—	37.1	38.1	34.9
SBI(N) 5-8	441	736	466	761	441	736	177	141	—	37.7	38.6	35.4
SBI(N) 5-9	468	763	493	788	468	763	177	141	—	38.2	39.2	35.9
SBI(N) 5-10	500	816	525	841	500	816	197	147	—	47.4	48.3	45.1
SBI(N) 5-11	527	843	552	868	527	843	197	147	—	47.9	48.8	45.6
SBI(N) 5-12	554	870	579	895	554	870	197	147	—	48.4	49.4	46.2
SBI(N) 5-13	581	907	606	932	581	907	220	161	—	53.0	53.9	50.7
SBI(N) 5-14	608	934	633	959	608	934	220	161	—	53.5	54.5	51.3
SBI(N) 5-15	635	961	660	986	635	961	220	161	—	54.1	55.0	51.8
SBI(N) 5-16	662	988	687	1013	662	988	220	161	—	54.6	55.6	52.4
SBI(N) 5-18	745	1107	770	1132	—	—	235	197	300	76.5	77.5	—
SBI(N) 5-20	799	1161	824	1186	—	—	235	197	300	77.8	78.7	—
SBI(N) 5-22	853	1215	878	1240	—	—	235	197	300	78.6	79.6	—
SBI(N) 5-24	907	1312	932	1337	—	—	235	197	300	85.6	86.5	—

Performance Range

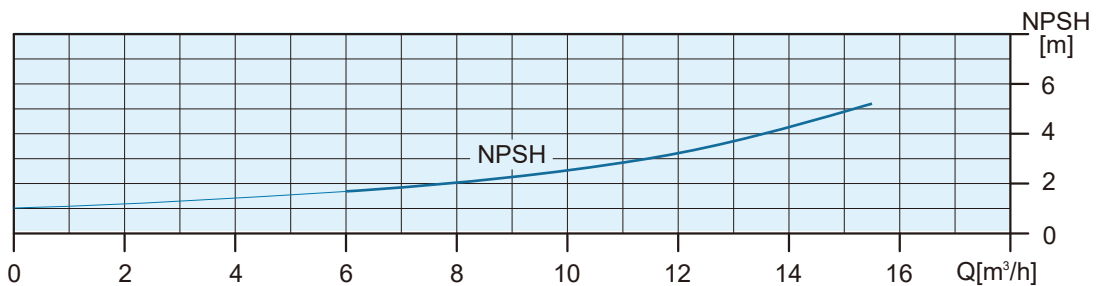
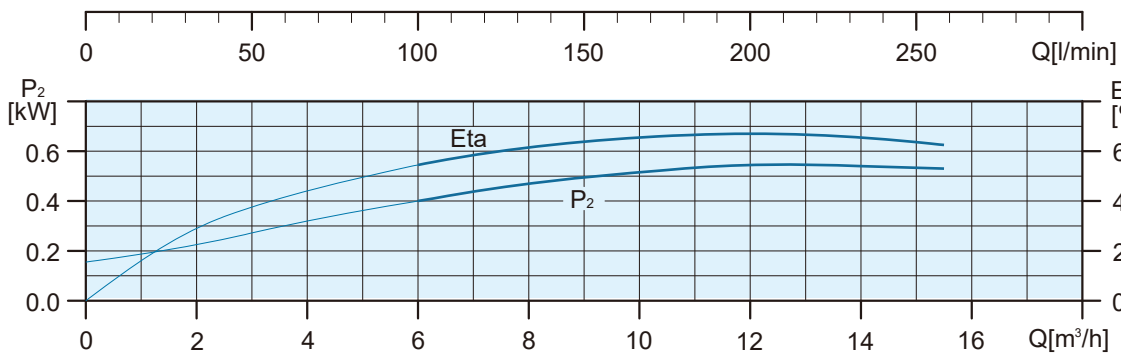
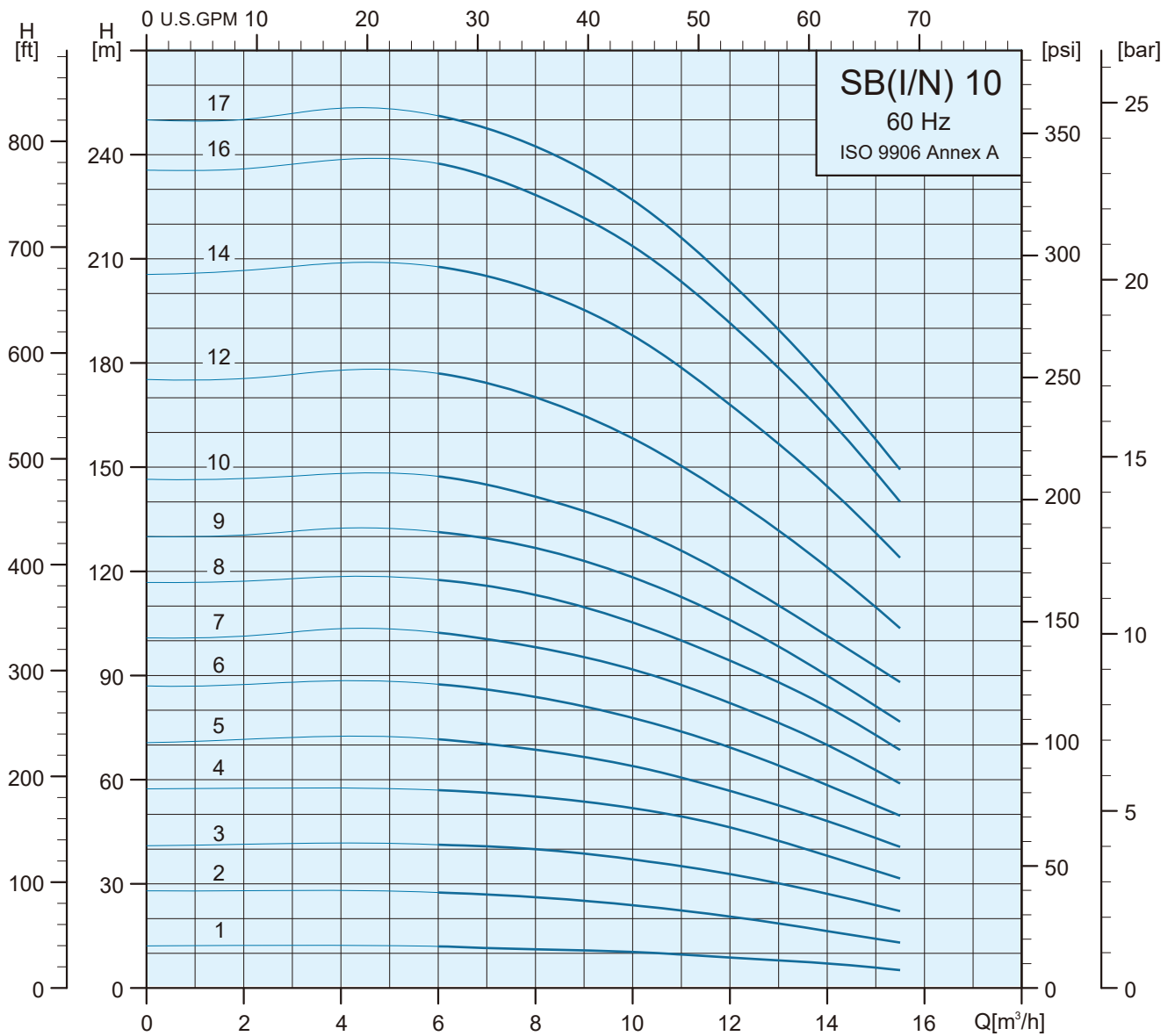

Specifications

Pump Type	Motor		Nominal Current [A]					
	P ₂		1 ϕ		3 ϕ		3 ϕ	
	kW	HP	110V/220V	220-240V	Δ 220-277V	Y380-480V	Δ 380-480V	Y660-830V
SB 10-1	0.75	1.0	10.4 / 5.2	—	3.1 - 3.0	1.8 - 1.7	—	—
SB 10-2	1.5	2.0	—	9.6 - 9.7	5.7 - 5.4	3.3 - 3.1	—	—
SB 10-3	2.2	3.0	—	13.8 - 12.5	8.1 - 7.2	4.7 - 4.2	—	—
SB 10-4	3.0	4.0	—	—	11.1 - 9.7	6.4 - 5.6	6.6 - 5.4	3.8 - 3.1
SB 10-5	3.0	4.0	—	—	11.1 - 9.7	6.4 - 5.6	6.6 - 5.4	3.8 - 3.1
SB 10-6	4.0	5.5	—	—	14.3 - 13.1	8.3 - 7.6	8.2 - 7.0	4.7 - 4.0
SB 10-7	5.5	7.5	—	—	19.2 - 16.9	11.1 - 9.8	11.2 - 9.6	6.5 - 5.5
SB 10-8	5.5	7.5	—	—	19.2 - 16.9	11.1 - 9.8	11.2 - 9.6	6.5 - 5.5
SB 10-9	5.5	7.5	—	—	19.2 - 16.9	11.1 - 9.8	11.2 - 9.6	6.5 - 5.5
SB 10-10	7.5	10.0	—	—	25.4 - 22.1	14.7 - 12.8	14.9 - 13.3	8.6 - 7.7
SB 10-12	7.5	10.0	—	—	25.4 - 22.1	14.7 - 12.8	14.9 - 13.3	8.6 - 7.7
SB 10-14	11.0	15.0	—	—	37.0 - 33.9	21.4 - 19.6	21.5 - 20.6	12.4 - 11.9
SB 10-16	11.0	15.0	—	—	37.0 - 33.9	21.4 - 19.6	21.5 - 20.6	12.4 - 11.9
SB 10-17	11.0	15.0	—	—	37.0 - 33.9	21.4 - 19.6	21.5 - 20.6	12.4 - 11.9

Dimensions and Weights

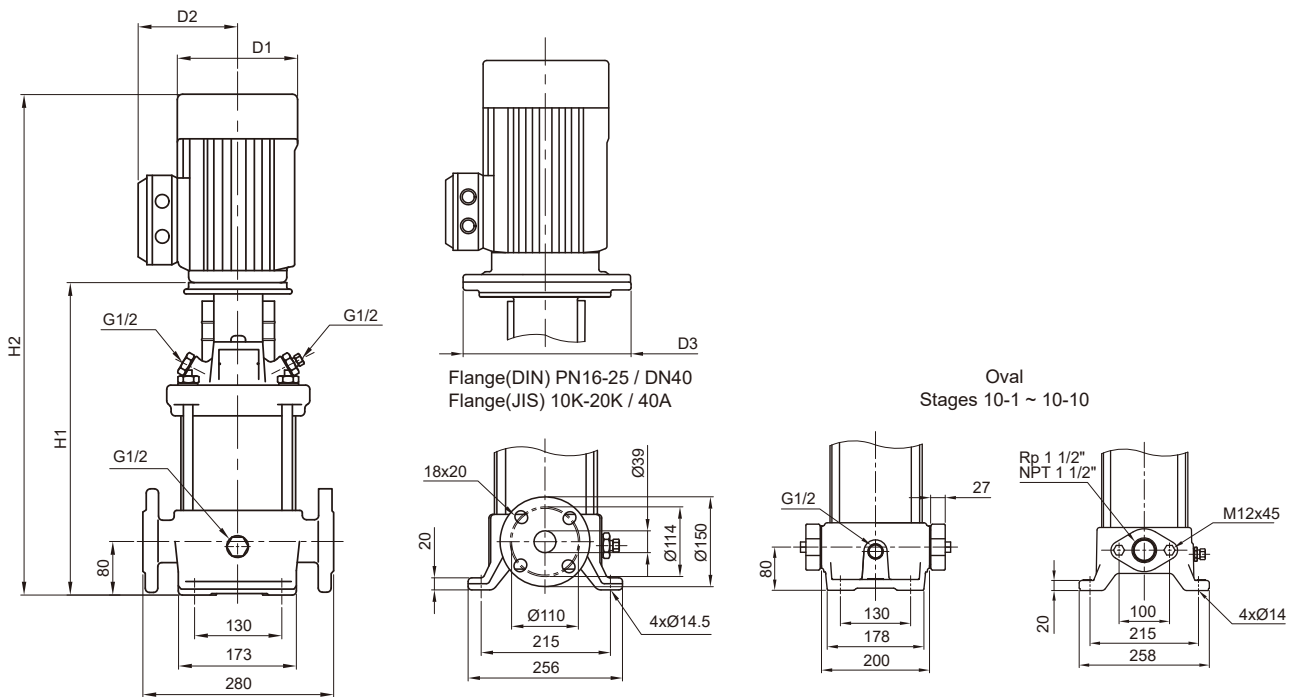

Pump Type	Dimensions (mm)							Net Weight (kg)	
	DIN flange		OVAL		D1	D2	D3	DIN flange	OVAL
	H1	H2	H1	H2					
SB 10-1	347	582	347	582	141	115	—	38.0	34.6
SB 10-2	363	658	363	658	177	141	—	49.0	45.6
SB 10-3	393	688	393	688	177	141	—	51.9	48.5
SB 10-4	428	744	428	744	197	147	—	62.1	58.7
SB 10-5	458	774	458	774	197	147	—	63.1	59.7
SB 10-6	488	814	488	814	220	161	—	68.2	64.8
SB 10-7	550	912	550	912	235	197	300	96.1	92.7
SB 10-8	580	942	580	942	235	197	300	97.2	93.8
SB 10-9	610	972	610	972	235	197	300	98.2	94.8
SB 10-10	640	1045	640	1045	235	197	300	105.2	101.8
SB 10-12	700	1105	—	—	235	197	300	107.2	—
SB 10-14	837	1282	—	—	269	215	350	140.5	—
SB 10-16	897	1342	—	—	269	215	350	142.6	—
SB 10-17	927	1372	—	—	269	215	350	143.7	—

Performance Range

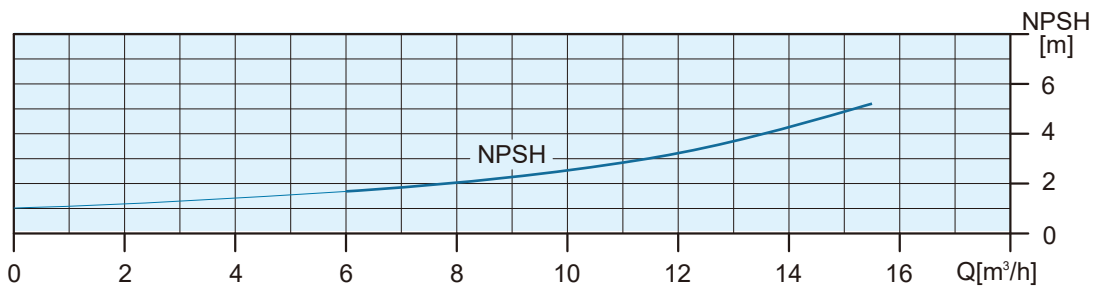
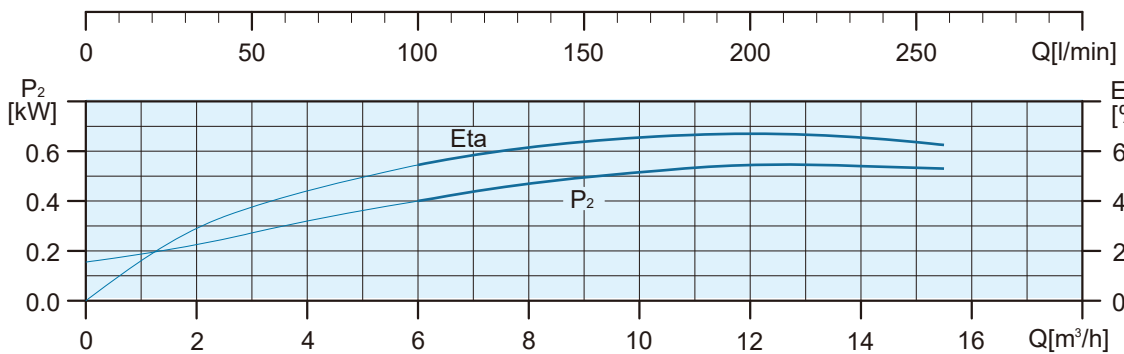
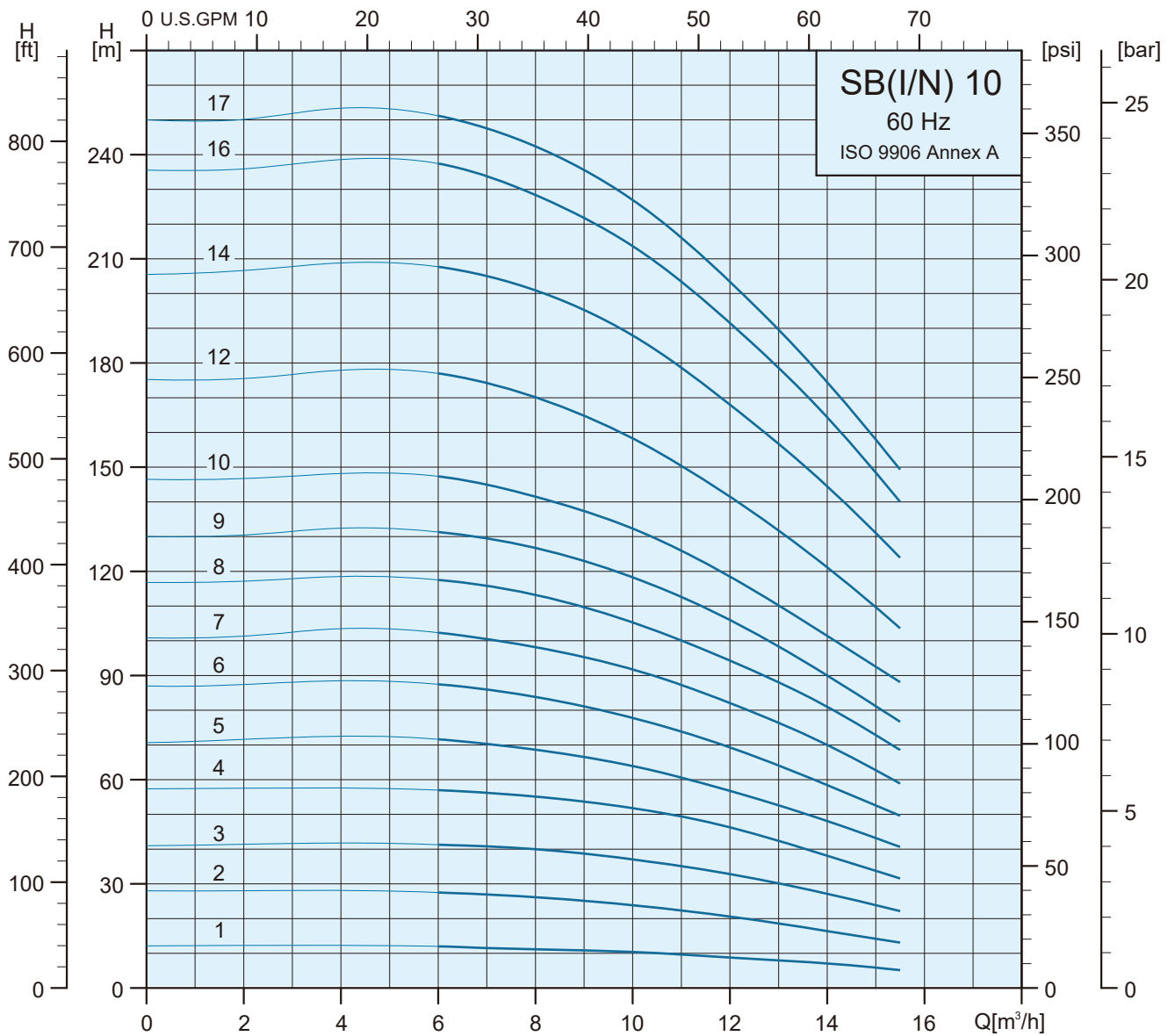

Specifications

Pump Type	Motor		Nominal Current [A]					
	P ₂		1 ϕ		3 ϕ		3 ϕ	
	kW	HP	110V/220V	220-240V	Δ 220-277V	Y380-480V	Δ 380-480V	Y660-830V
SBI(N) 10-1	0.75	1.0	10.4 / 5.2	—	3.1 - 3.0	1.8 - 1.7	—	—
SBI(N) 10-2	1.5	2.0	—	9.6 - 9.7	5.7 - 5.4	3.3 - 3.1	—	—
SBI(N) 10-3	2.2	3.0	—	13.8 - 12.5	8.1 - 7.2	4.7 - 4.2	—	—
SBI(N) 10-4	3.0	4.0	—	—	11.1 - 9.7	6.4 - 5.6	6.6 - 5.4	3.8 - 3.1
SBI(N) 10-5	3.0	4.0	—	—	11.1 - 9.7	6.4 - 5.6	6.6 - 5.4	3.8 - 3.1
SBI(N) 10-6	4.0	5.5	—	—	14.3 - 13.1	8.3 - 7.6	8.2 - 7.0	4.7 - 4.0
SBI(N) 10-7	5.5	7.5	—	—	19.2 - 16.9	11.1 - 9.8	11.2 - 9.6	6.5 - 5.5
SBI(N) 10-8	5.5	7.5	—	—	19.2 - 16.9	11.1 - 9.8	11.2 - 9.6	6.5 - 5.5
SBI(N) 10-9	5.5	7.5	—	—	19.2 - 16.9	11.1 - 9.8	11.2 - 9.6	6.5 - 5.5
SBI(N) 10-10	7.5	10.0	—	—	25.4 - 22.1	14.7 - 12.8	14.9 - 13.3	8.6 - 7.7
SBI(N) 10-12	7.5	10.0	—	—	25.4 - 22.1	14.7 - 12.8	14.9 - 13.3	8.6 - 7.7
SBI(N) 10-14	11.0	15.0	—	—	37.0 - 33.9	21.4 - 19.6	21.5 - 20.6	12.4 - 11.9
SBI(N) 10-16	11.0	15.0	—	—	37.0 - 33.9	21.4 - 19.6	21.5 - 20.6	12.4 - 11.9
SBI(N) 10-17	11.0	15.0	—	—	37.0 - 33.9	21.4 - 19.6	21.5 - 20.6	12.4 - 11.9

Dimensions and Weights

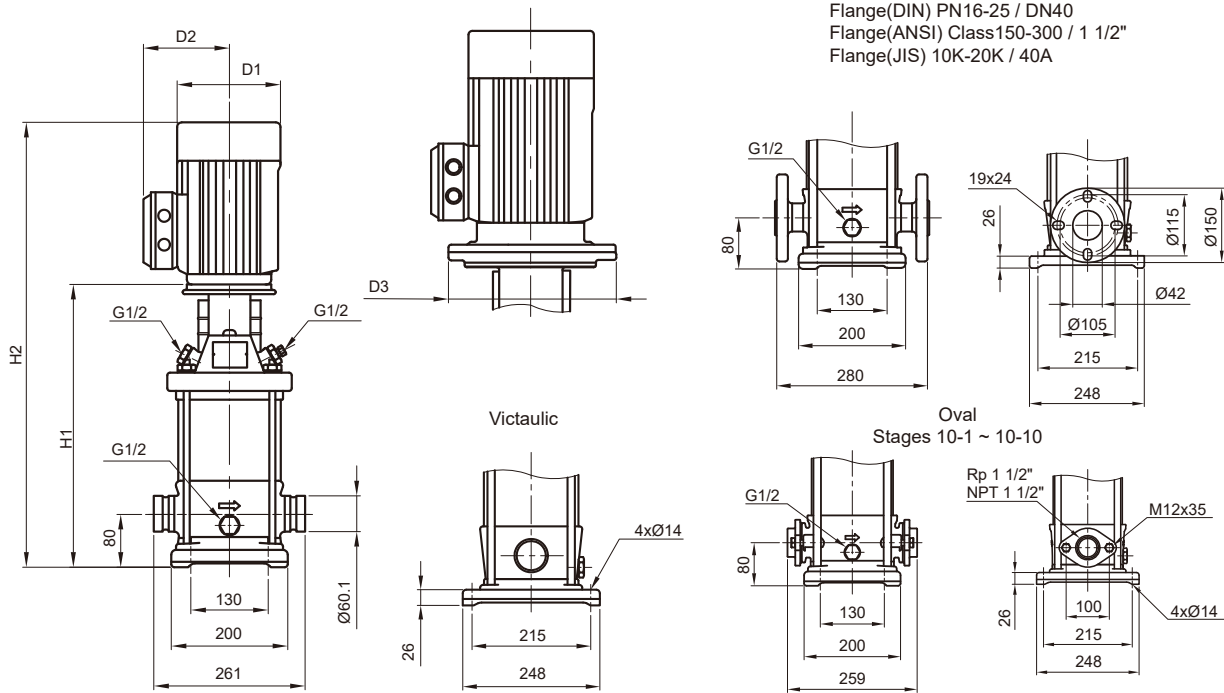

Pump Type	Dimensions (mm)						Net Weight (kg)					
	Victaulic		DIN flange		OVAL		D1	D2	D3	Victaulic	DIN flange	OVAL
	H1	H2	H1	H2	H1	H2						
SBI(N) 10-1	357	592	357	592	357	592	141	115	—	34.1	34.0	32.5
SBI(N) 10-2	373	668	373	668	373	668	177	141	—	45.1	45.0	43.5
SBI(N) 10-3	403	698	403	698	403	698	177	141	—	47.9	47.8	46.3
SBI(N) 10-4	438	754	438	754	438	754	197	147	—	57.3	57.2	55.7
SBI(N) 10-5	468	784	468	784	468	784	197	147	—	58.4	58.2	56.7
SBI(N) 10-6	498	824	498	824	498	824	220	161	—	63.4	63.3	61.8
SBI(N) 10-7	560	922	560	922	560	922	235	197	300	92.5	92.4	90.9
SBI(N) 10-8	590	952	590	952	590	952	235	197	300	93.6	93.4	91.9
SBI(N) 10-9	620	982	620	982	620	982	235	197	300	94.6	94.4	92.9
SBI(N) 10-10	650	1055	650	1055	650	1055	235	197	300	101.5	101.4	99.9
SBI(N) 10-12	710	1115	710	1115	—	—	235	197	300	103.6	103.4	—
SBI(N) 10-14	847	1292	847	1292	—	—	269	215	350	137.2	137.0	—
SBI(N) 10-16	907	1352	907	1352	—	—	269	215	350	139.2	139.1	—
SBI(N) 10-17	937	1382	937	1382	—	—	269	215	350	140.4	140.2	—

Performance Range

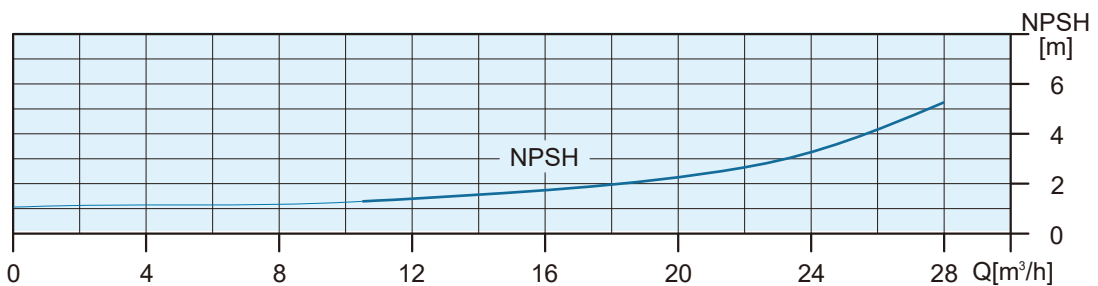
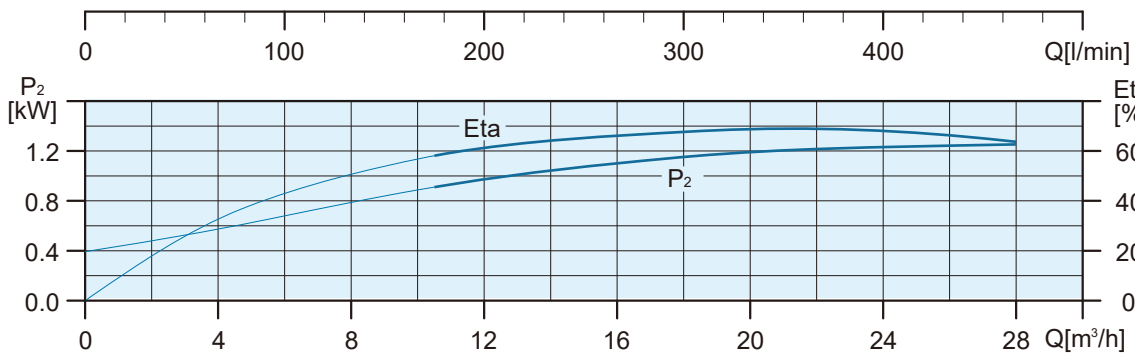
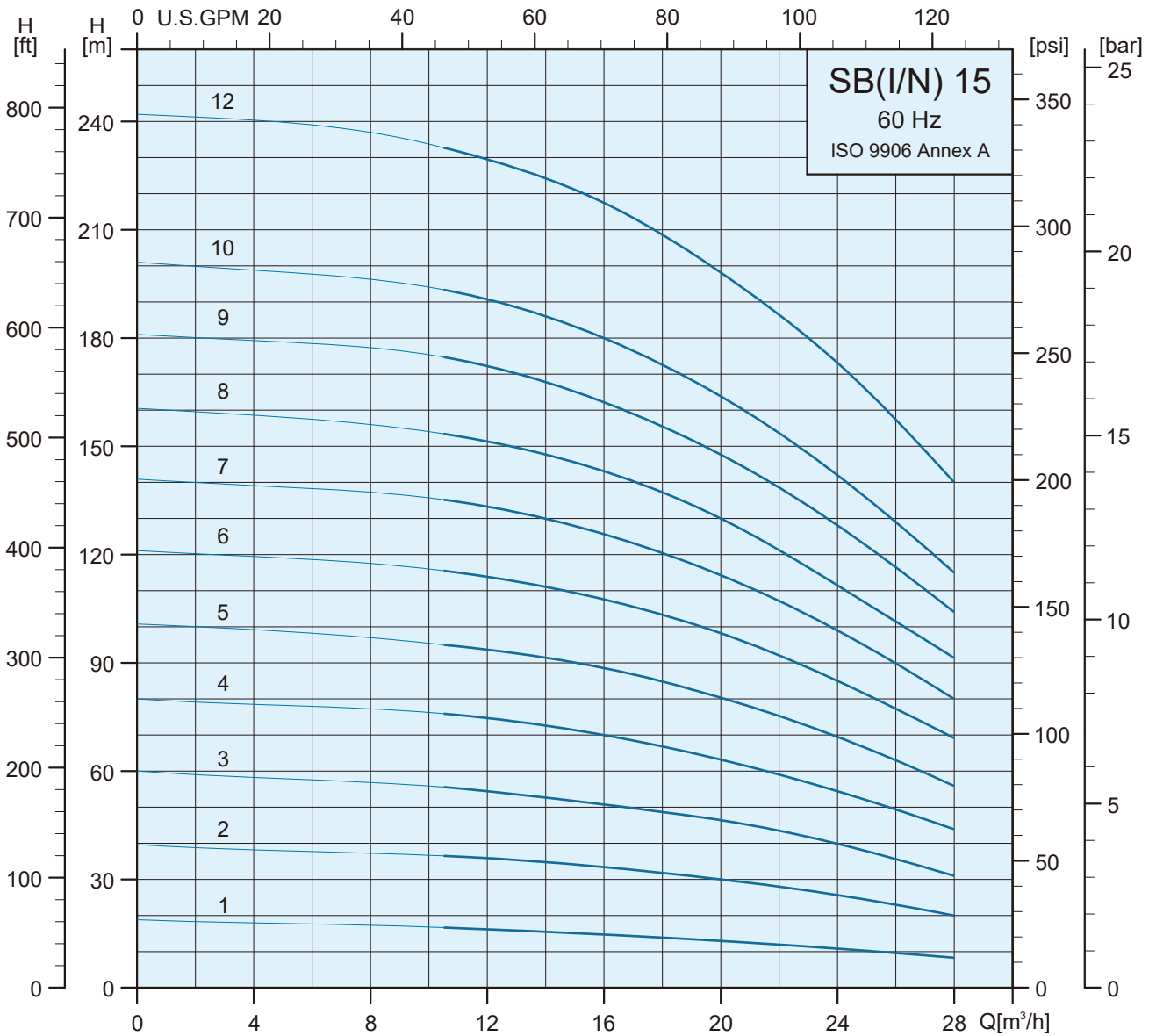

Specifications

Pump Type	Motor		Nominal Current [A]				
	P ₂		1 ϕ	3 ϕ		3 ϕ	
	kW	HP	220-240V	Δ 220-277V	Y380-480V	Δ 380-480V	Y660-830V
SB 15-1	1.5	2.0	9.6 - 9.7	5.7 - 5.4	3.3 - 3.1	—	—
SB 15-2	3.0	4.0	—	11.1 - 9.7	6.4 - 5.6	6.6 - 5.4	3.8 - 3.1
SB 15-3	4.0	5.5	—	14.3 - 13.1	8.3 - 7.6	8.2 - 7.0	4.7 - 4.0
SB 15-4	5.5	7.5	—	19.2 - 16.9	11.1 - 9.8	11.2 - 9.6	6.5 - 5.5
SB 15-5	7.5	10.0	—	25.4 - 22.1	14.7 - 12.8	14.9 - 13.3	8.6 - 7.7
SB 15-6	11.0	15.0	—	37.0 - 33.9	21.4 - 19.6	21.5 - 20.6	12.4 - 11.9
SB 15-7	11.0	15.0	—	37.0 - 33.9	21.4 - 19.6	21.5 - 20.6	12.4 - 11.9
SB 15-8	11.0	15.0	—	37.0 - 33.9	21.4 - 19.6	21.5 - 20.6	12.4 - 11.9
SB 15-9	15.0	20.0	—	48.5 - 40.7	28.0 - 23.5	28.5 - 24.9	16.4 - 14.3
SB 15-10	15.0	20.0	—	48.5 - 40.7	28.0 - 23.5	28.5 - 24.9	16.4 - 14.3
SB 15-12	18.5	25.0	—	59.7 - 49.3	34.5 - 28.5	34.6 - 28.9	19.9 - 16.6

Dimensions and Weights

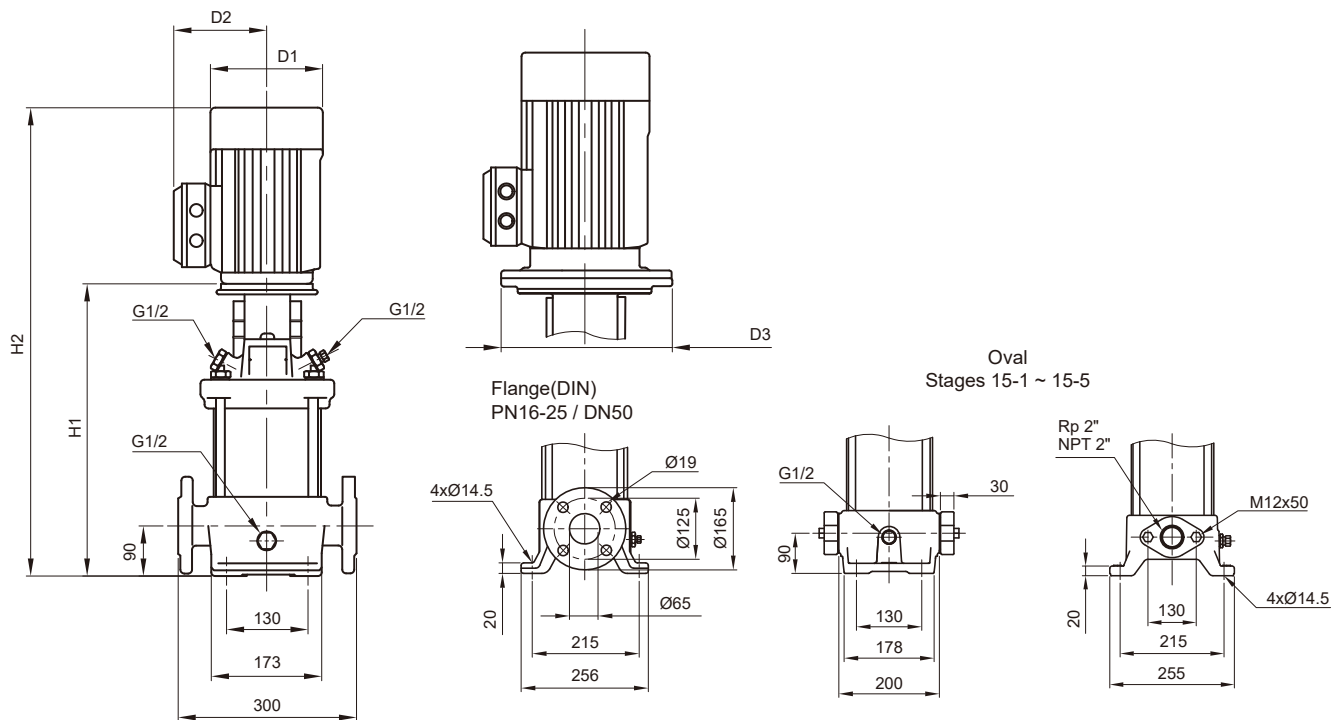

Pump Type	Dimensions (mm)							Net Weight (kg)	
	DIN flange		OVAL		D1	D2	D3	DIN flange	OVAL
	H1	H2	H1	H2					
SB 15-1	415	710	415	710	177	141	—	53.6	52.0
SB 15-2	420	736	420	736	197	147	—	64.9	63.3
SB 15-3	465	791	465	791	220	161	—	70.3	68.7
SB 15-4	542	904	542	904	235	197	300	98.7	97.1
SB 15-5	587	992	587	992	235	197	300	106.0	104.4
SB 15-6	709	1154	—	—	269	215	350	138.7	—
SB 15-7	754	1199	—	—	269	215	350	140.2	—
SB 15-8	799	1244	—	—	269	215	350	141.6	—
SB 15-9	844	1334	—	—	269	215	350	153.7	—
SB 15-10	889	1379	—	—	269	215	350	155.2	—
SB 15-12	979	1519	—	—	318	241	350	192.0	—

Performance Range

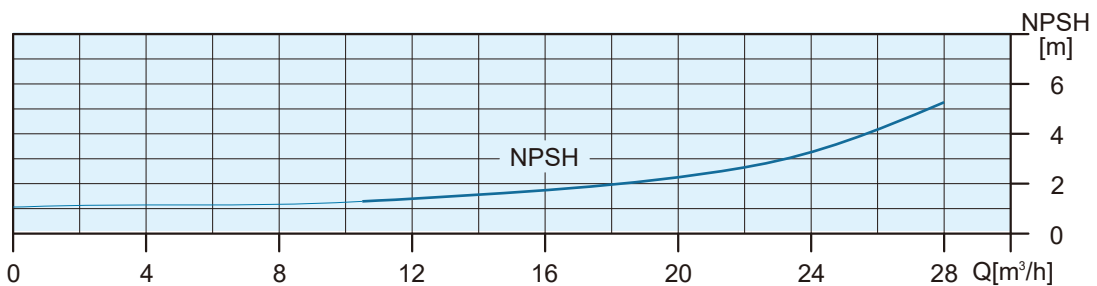
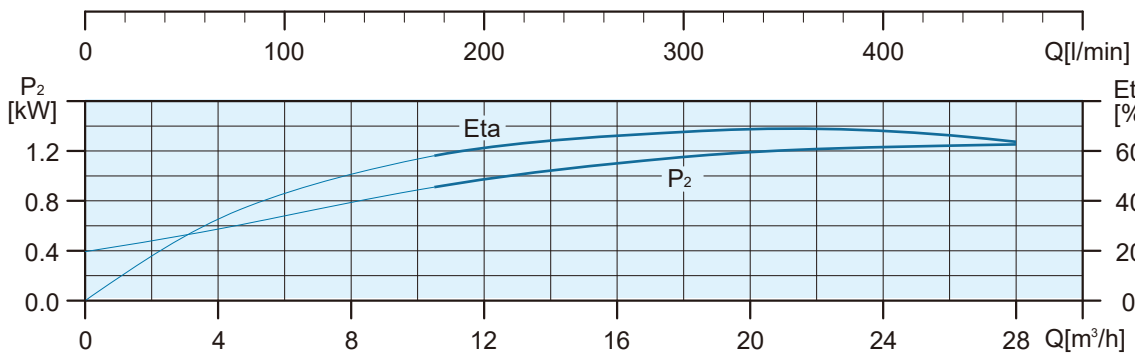
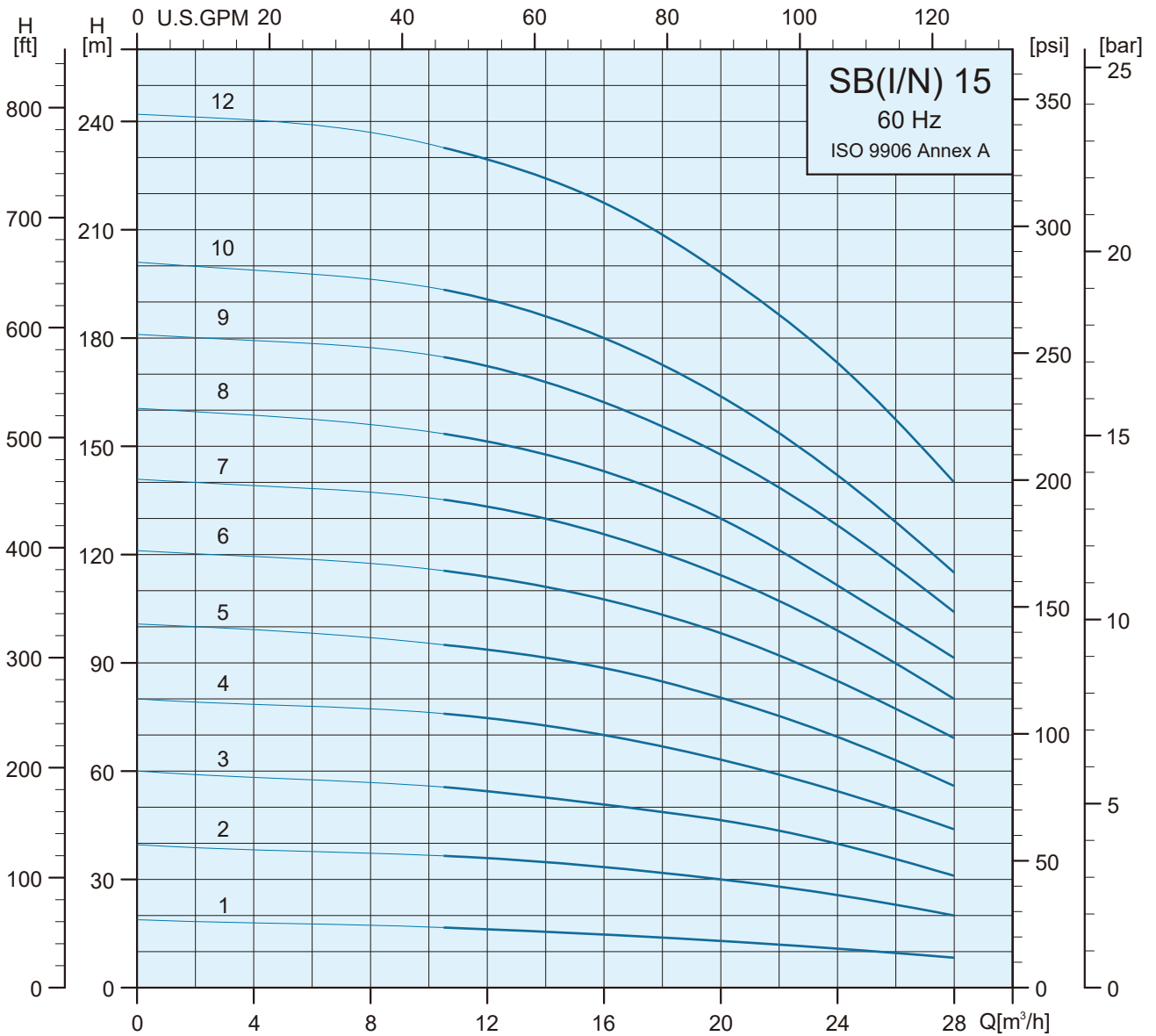

Specifications

Pump Type	Motor		Nominal Current [A]				
	P ₂		1φ	3φ		3φ	
	kW	HP	220-240V	△220-277V	Y380-480V	△380-480V	Y660-830V
SBI(N) 15-1	1.5	2.0	9.6 - 9.7	5.7 - 5.4	3.3 - 3.1	—	—
SBI(N) 15-2	3.0	4.0	—	11.1 - 9.7	6.4 - 5.6	6.6 - 5.4	3.8 - 3.1
SBI(N) 15-3	4.0	5.5	—	14.3 - 13.1	8.3 - 7.6	8.2 - 7.0	4.7 - 4.0
SBI(N) 15-4	5.5	7.5	—	19.2 - 16.9	11.1 - 9.8	11.2 - 9.6	6.5 - 5.5
SBI(N) 15-5	7.5	10.0	—	25.4 - 22.1	14.7 - 12.8	14.9 - 13.3	8.6 - 7.7
SBI(N) 15-6	11.0	15.0	—	37.0 - 33.9	21.4 - 19.6	21.5 - 20.6	12.4 - 11.9
SBI(N) 15-7	11.0	15.0	—	37.0 - 33.9	21.4 - 19.6	21.5 - 20.6	12.4 - 11.9
SBI(N) 15-8	11.0	15.0	—	37.0 - 33.9	21.4 - 19.6	21.5 - 20.6	12.4 - 11.9
SBI(N) 15-9	15.0	20.0	—	48.5 - 40.7	28.0 - 23.5	28.5 - 24.9	16.4 - 14.3
SBI(N) 15-10	15.0	20.0	—	48.5 - 40.7	28.0 - 23.5	28.5 - 24.9	16.4 - 14.3
SBI(N) 15-12	18.5	25.0	—	59.7 - 49.3	34.5 - 28.5	34.6 - 28.9	19.9 - 16.6

Dimensions and Weights

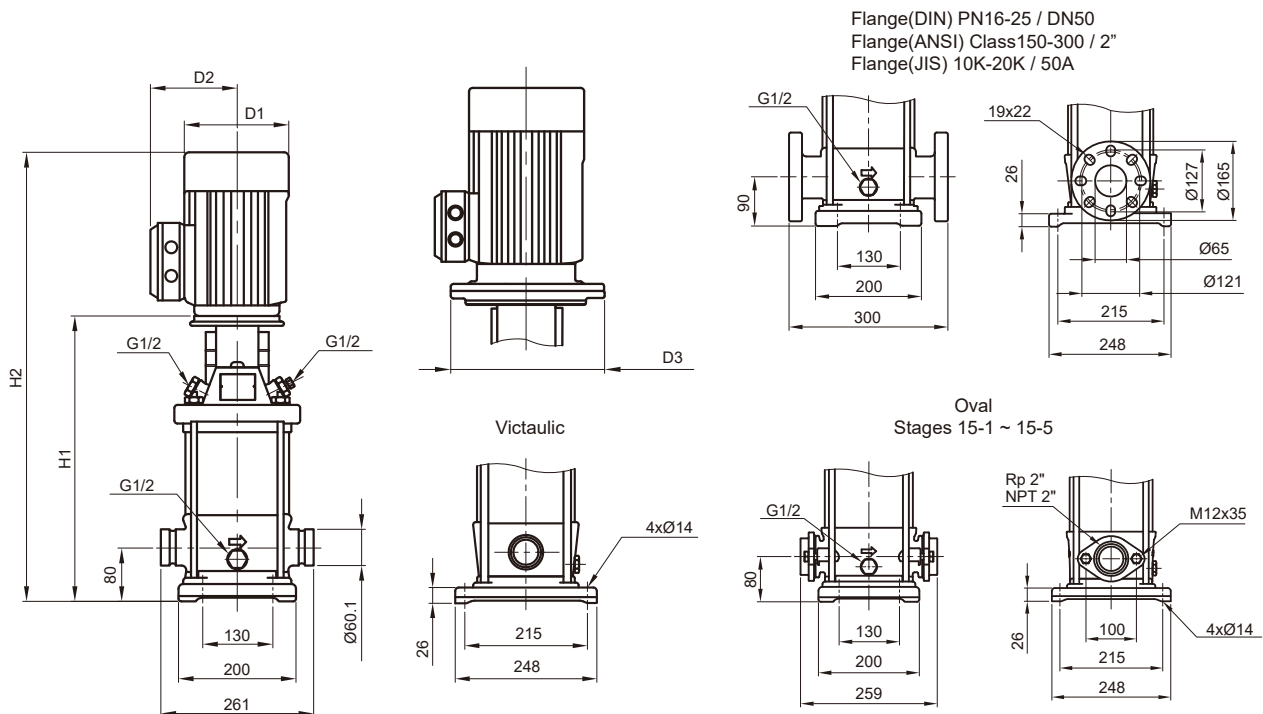

Pump Type	Dimensions (mm)									Net Weight (kg)		
	Victaulic		DIN flange		OVAL		D1	D2	D3	Victaulic	DIN flange	OVAL
	H1	H2	H1	H2	H1	H2						
SBI(N) 15-1	403	698	413	708	403	698	177	141	—	45.6	46.3	42.7
SBI(N) 15-2	408	724	418	734	408	724	197	147	—	56.1	56.7	53.1
SBI(N) 15-3	453	779	463	789	453	779	220	161	—	61.5	62.1	58.5
SBI(N) 15-4	530	892	540	902	530	892	235	197	300	91.0	91.6	88.0
SBI(N) 15-5	575	980	585	990	575	980	235	197	300	98.3	99.0	95.3
SBI(N) 15-6	697	1142	707	1152	—	—	269	215	350	131.4	132.0	—
SBI(N) 15-7	742	1187	752	1197	—	—	269	215	350	132.8	133.4	—
SBI(N) 15-8	787	1232	797	1242	—	—	269	215	350	134.2	134.8	—
SBI(N) 15-9	832	1322	842	1332	—	—	269	215	350	146.4	147.0	—
SBI(N) 15-10	877	1367	887	1377	—	—	269	215	350	147.9	148.5	—
SBI(N) 15-12	967	1507	977	1517	—	—	318	241	350	184.5	182.2	—

Performance Range

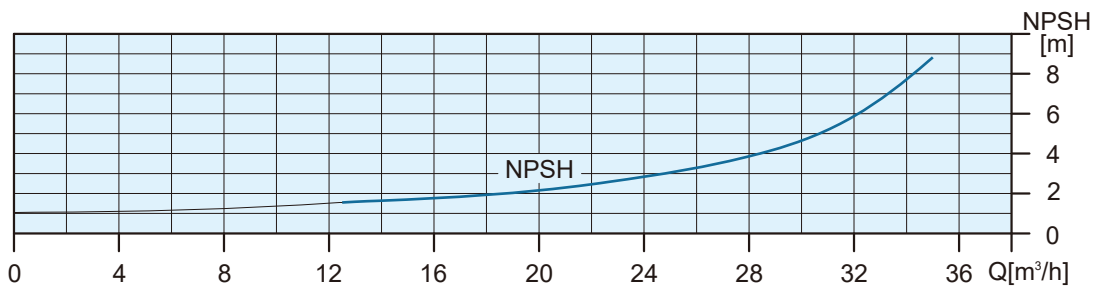
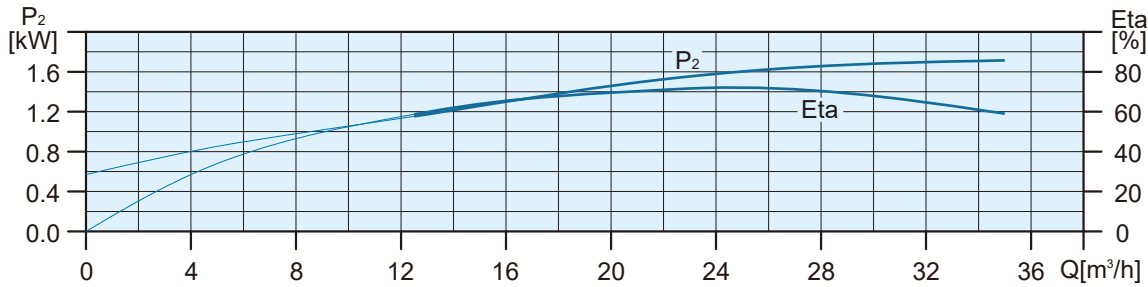
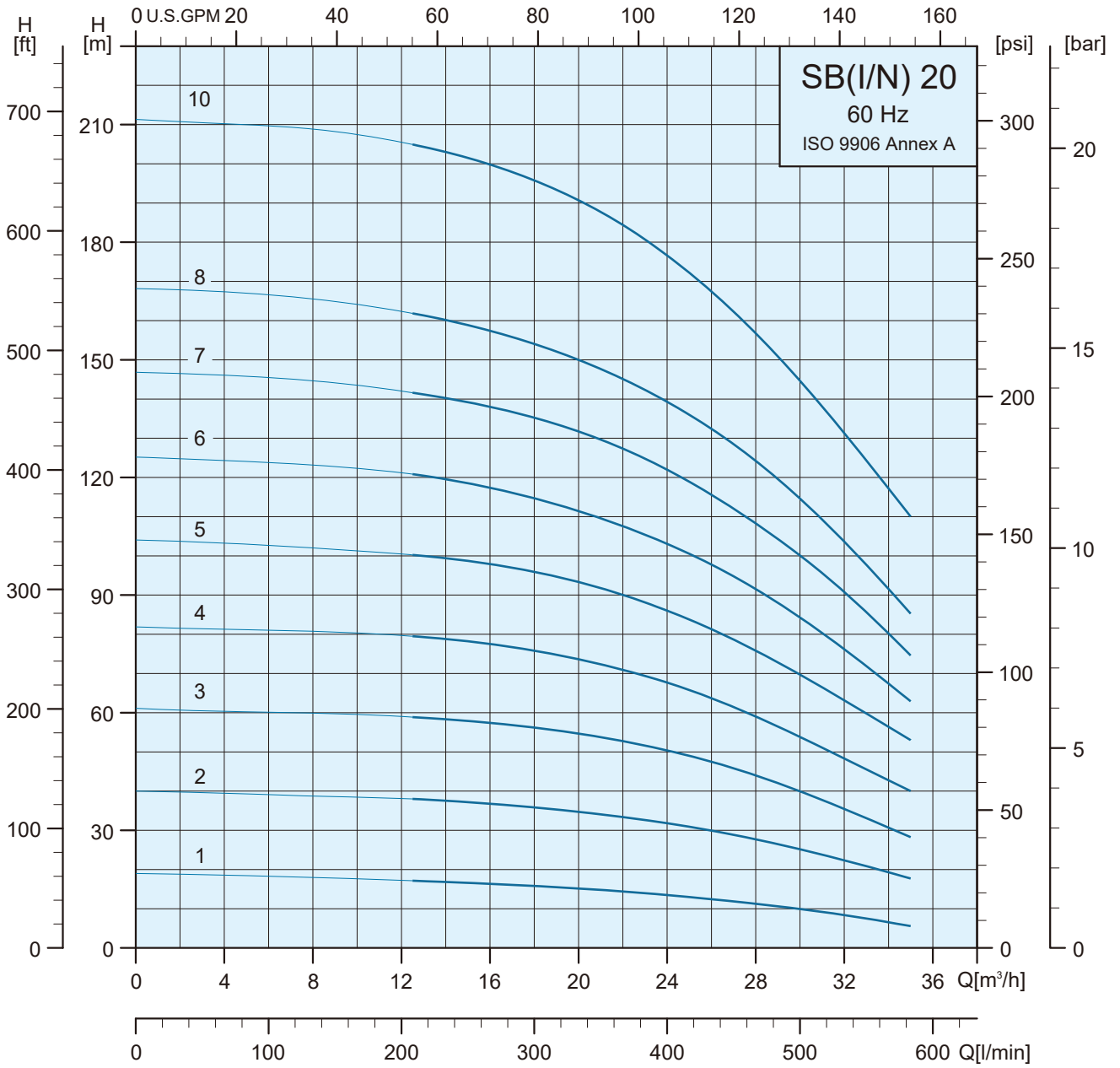

Specifications

Pump Type	Motor		Nominal Current [A]				
	P ₂		1 ϕ	3 ϕ		3 ϕ	
	kW	HP	220-240V	Δ 220-277V	Y380-480V	Δ 380-480V	Y660-830V
SB 20-1	2.2	3.0	13.8 - 12.5	8.1 - 7.2	4.7 - 4.2	—	—
SB 20-2	4.0	5.5	—	14.3 - 13.1	8.3 - 7.6	8.2 - 7.0	4.7 - 4.0
SB 20-3	5.5	7.5	—	19.2 - 16.9	11.1 - 9.8	11.2 - 9.6	6.5 - 5.5
SB 20-4	7.5	10.0	—	25.4 - 22.1	14.7 - 12.8	14.9 - 13.3	8.6 - 7.7
SB 20-5	11.0	15.0	—	37.0 - 33.9	21.4 - 19.6	21.5 - 20.6	12.4 - 11.9
SB 20-6	11.0	15.0	—	37.0 - 33.9	21.4 - 19.6	21.5 - 20.6	12.4 - 11.9
SB 20-7	15.0	20.0	—	48.5 - 40.7	28.0 - 23.5	28.5 - 24.9	16.4 - 14.3
SB 20-8	15.0	20.0	—	48.5 - 40.7	28.0 - 23.5	28.5 - 24.9	16.4 - 14.3
SB 20-10	18.5	25.0	—	59.7 - 49.3	34.5 - 28.5	34.6 - 28.9	19.9 - 16.6

Dimensions and Weights

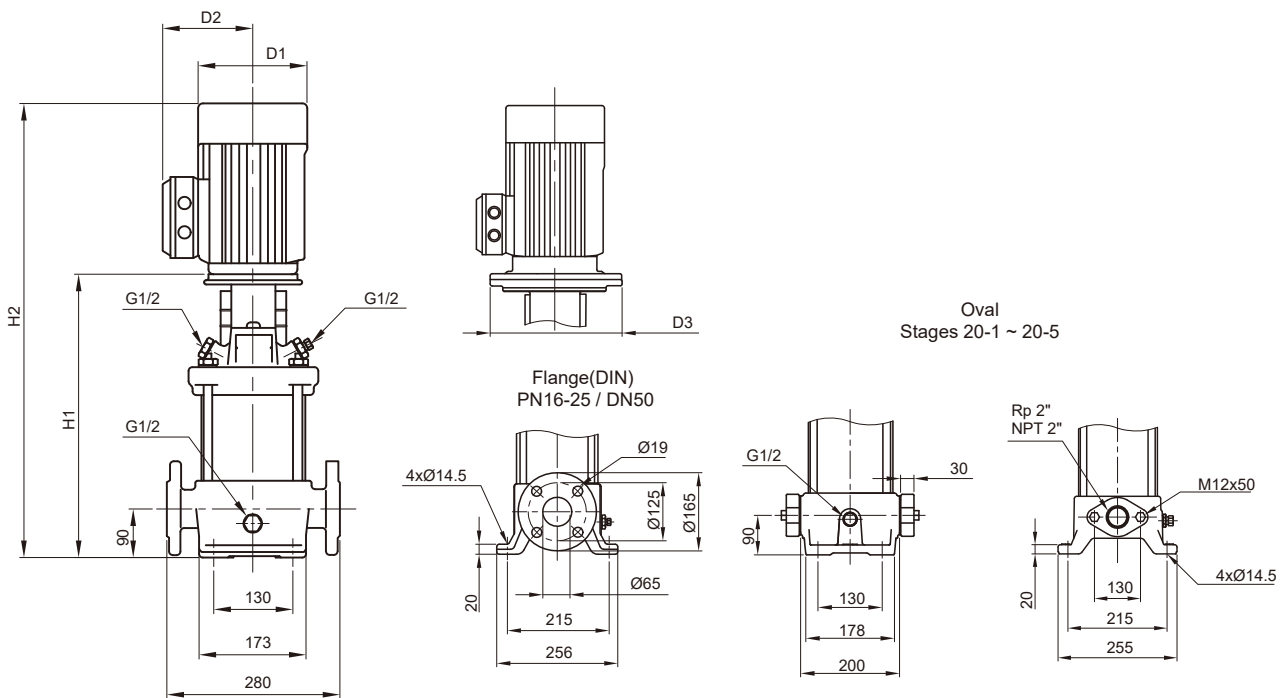

Pump Type	Dimensions (mm)							Net Weight (kg)	
	DIN flange		OVAL		D1	D2	D3	DIN flange	OVAL
	H1	H2	H1	H2					
SB 20-1	415	710	415	710	177	141	—	55.4	53.8
SB 20-2	420	746	420	746	220	161	—	68.9	67.3
SB 20-3	497	859	497	859	235	197	300	97.4	95.8
SB 20-4	542	947	542	947	235	197	300	104.6	102.9
SB 20-5	664	1109	664	1109	269	215	350	137.2	135.6
SB 20-6	709	1154	—	—	269	215	350	138.7	—
SB 20-7	754	1244	—	—	269	215	350	150.9	—
SB 20-8	799	1289	—	—	269	215	350	152.3	—
SB 20-10	889	1429	—	—	318	241	350	189.0	—

Performance Range

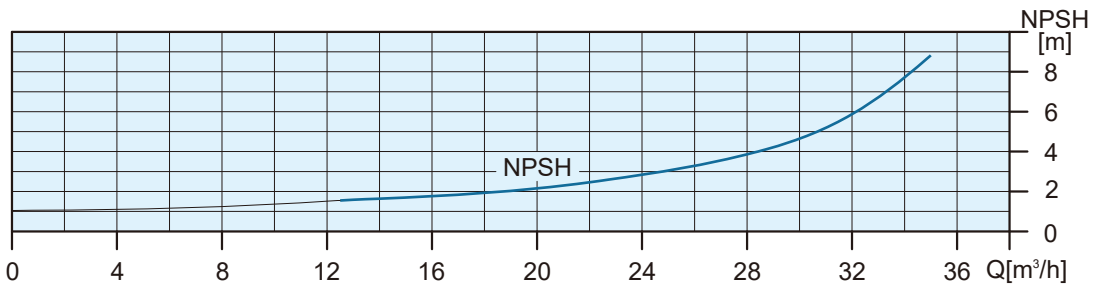
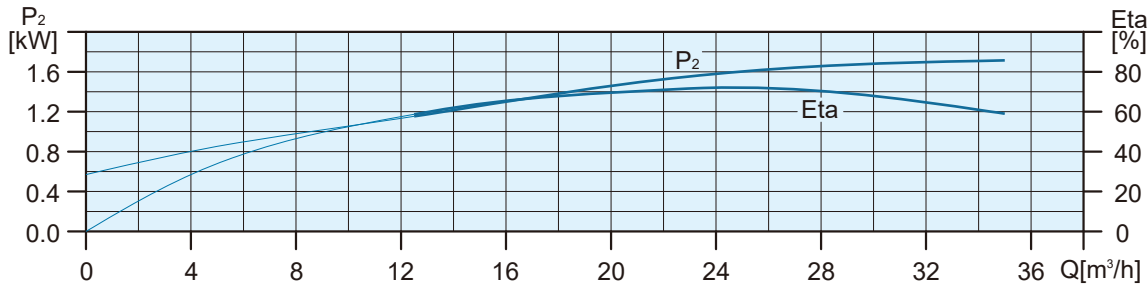
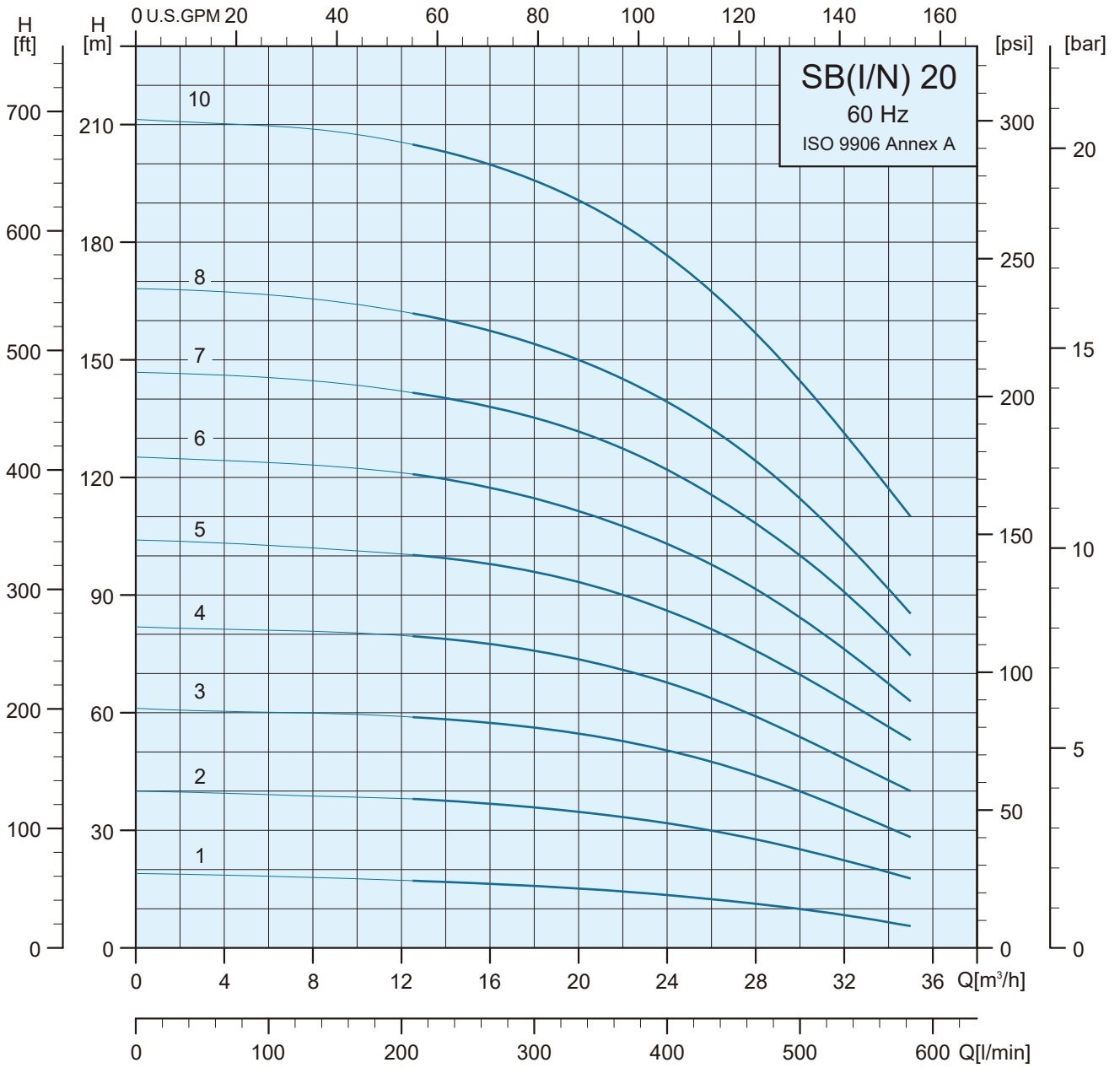

Specifications

Pump Type	Motor		Nominal Current [A]				
	P ₂		1φ	3φ		3φ	
	kW	HP	220-240V	△220-277V	Y380-480V	△380-480V	Y660-830V
SBI(N) 20-1	2.2	3.0	13.8 - 12.5	8.1 - 7.2	4.7 - 4.2	—	—
SBI(N) 20-2	4.0	5.5	—	14.3 - 13.1	8.3 - 7.6	8.2 - 7.0	4.7 - 4.0
SBI(N) 20-3	5.5	7.5	—	19.2 - 16.9	11.1 - 9.8	11.2 - 9.6	6.5 - 5.5
SBI(N) 20-4	7.5	10.0	—	25.4 - 22.1	14.7 - 12.8	14.9 - 13.3	8.6 - 7.7
SBI(N) 20-5	11.0	15.0	—	37.0 - 33.9	21.4 - 19.6	21.5 - 20.6	12.4 - 11.9
SBI(N) 20-6	11.0	15.0	—	37.0 - 33.9	21.4 - 19.6	21.5 - 20.6	12.4 - 11.9
SBI(N) 20-7	15.0	20.0	—	48.5 - 40.7	28.0 - 23.5	28.5 - 24.9	16.4 - 14.3
SBI(N) 20-8	15.0	20.0	—	48.5 - 40.7	28.0 - 23.5	28.5 - 24.9	16.4 - 14.3
SBI(N) 20-10	18.5	25.0	—	59.7 - 49.3	34.5 - 28.5	34.6 - 28.9	19.9 - 16.6

Dimensions and Weights

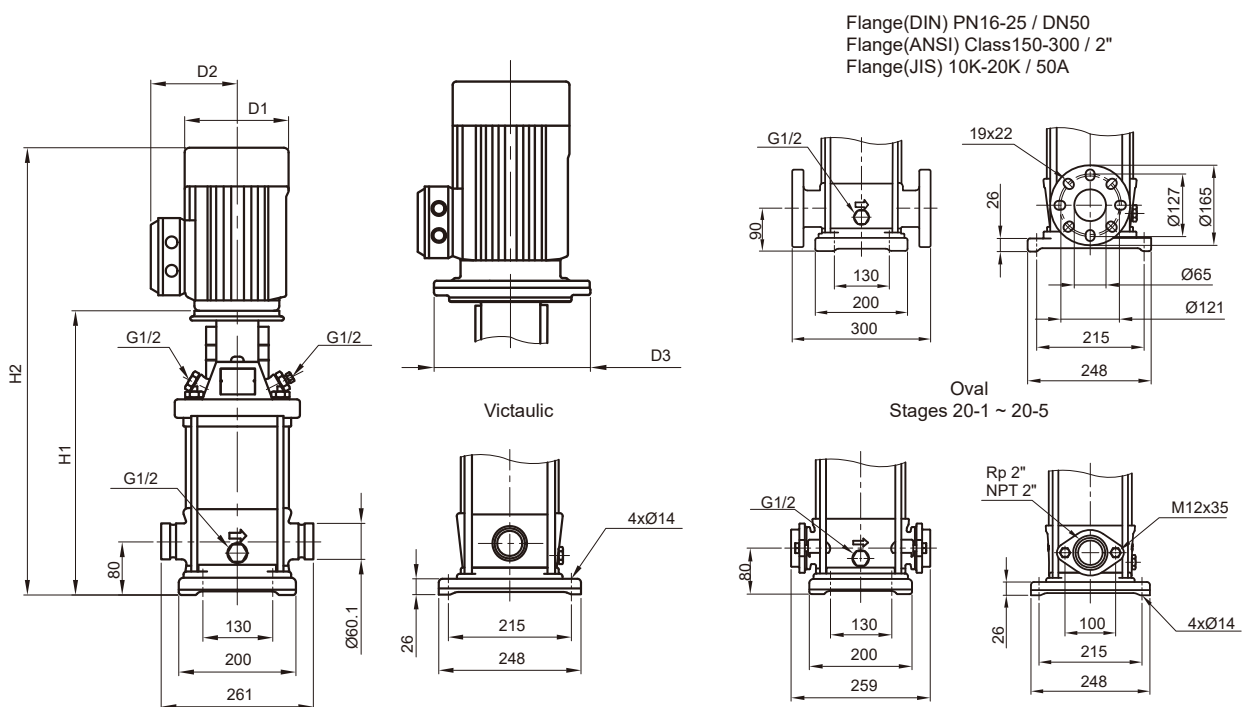

Pump Type	Dimensions (mm)									Net Weight (kg)		
	Victaulic		DIN flange		OVAL		D1	D2	D3	Victaulic	DIN flange	OVAL
	H1	H2	H1	H2	H1	H2						
SBI(N) 20-1	405	700	415	710	405	700	177	141	—	47.4	48.1	44.4
SBI(N) 20-2	410	736	420	746	410	736	220	161	—	60.1	60.7	57.1
SBI(N) 20-3	487	849	497	859	487	849	235	197	300	89.6	90.2	86.6
SBI(N) 20-4	532	937	542	947	532	937	235	197	300	96.9	97.5	93.9
SBI(N) 20-5	654	1099	664	1109	654	1099	269	215	350	129.9	130.5	126.9
SBI(N) 20-6	699	1144	709	1154	—	—	269	215	350	131.4	132.0	—
SBI(N) 20-7	744	1234	754	1244	—	—	269	215	350	143.5	144.1	—
SBI(N) 20-8	789	1279	799	1289	—	—	269	215	350	144.9	145.5	—
SBI(N) 20-10	879	1419	889	1429	—	—	318	241	350	181.7	182.3	—

Performance Range

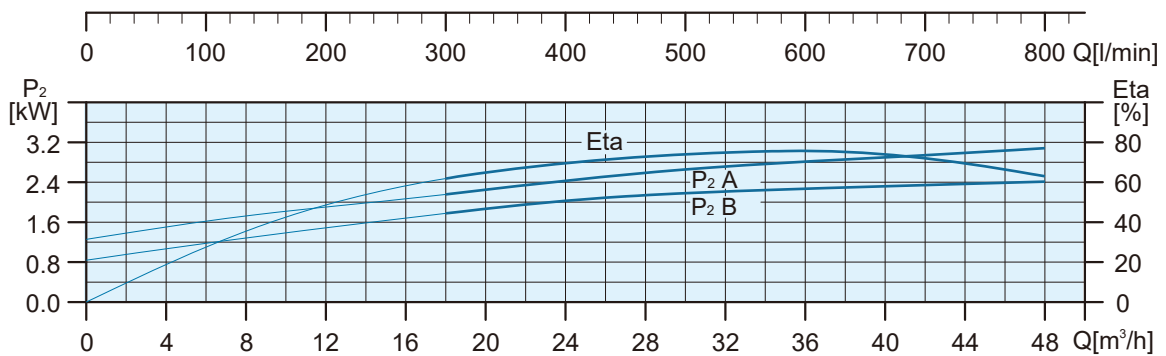
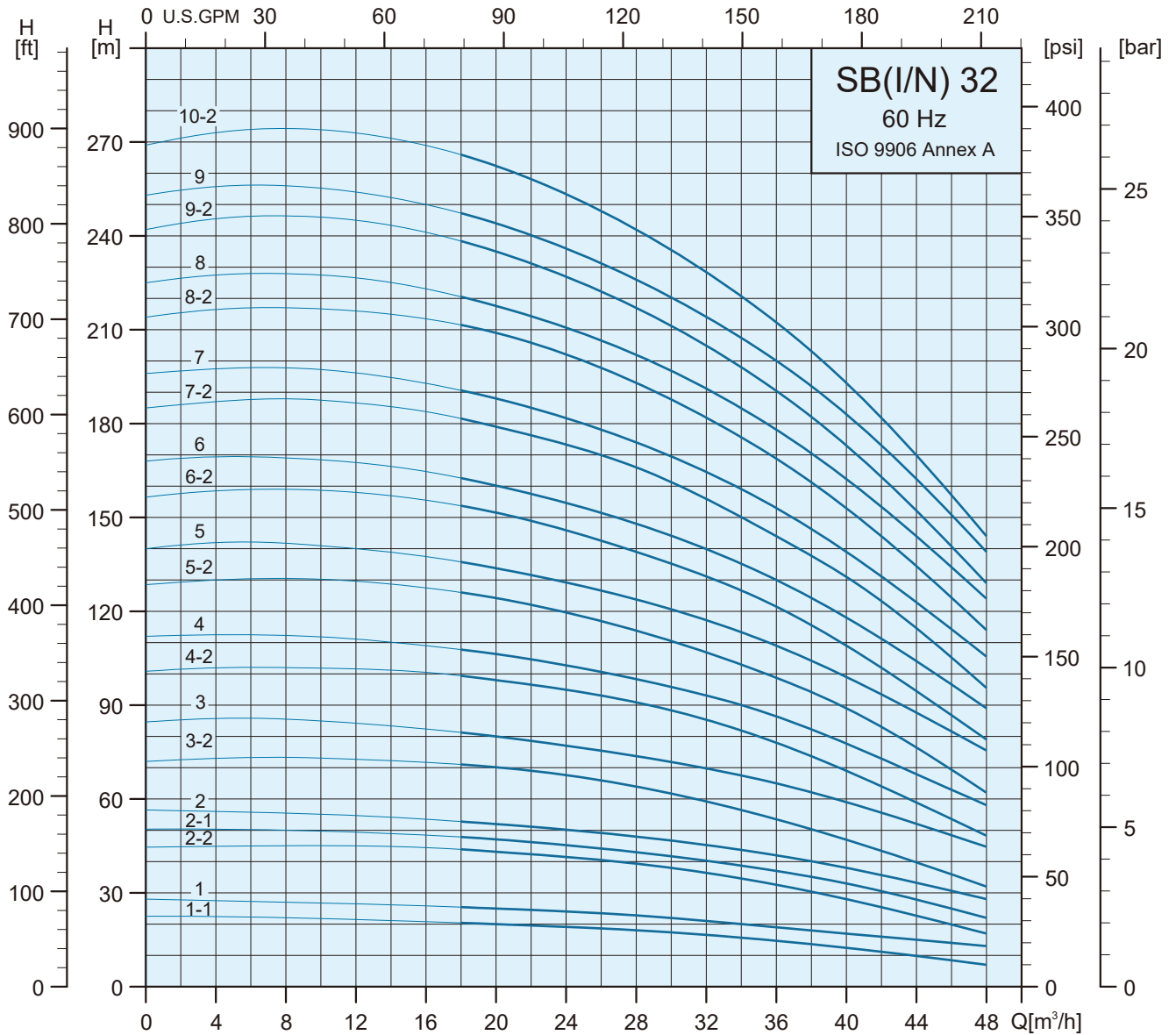

*The P2 power of single impeller show A means regular impeller, Show B means small impeller

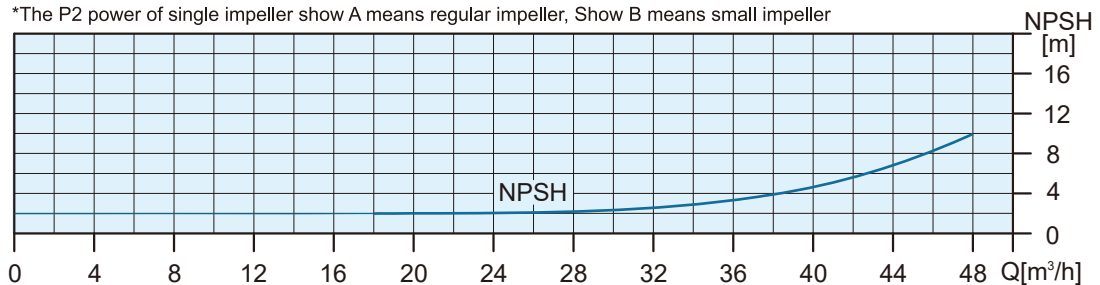

Specifications

Pump Type	Motor		Nominal Current [A]									
	P ₂		1 ϕ	3 ϕ			3 ϕ			3 ϕ		
	kW	HP	220-240V	Δ 220-277V	Y380-480V	Δ 220-240V	Y380-415V	Δ 380-480V	Y660-830V	Δ 380-415V	Y660-720V	Δ 460V
SB 32-1-1	2.2	3.0	13.8 - 12.5	8.1 - 7.2	4.7 - 4.2	—	—	—	—	—	—	—
SB 32-1	3.0	4.0	—	11.1 - 9.7	6.4 - 5.6	—	—	6.6 - 5.4	3.8 - 3.1	—	—	—
SB 32-2-2	5.5	7.5	—	19.2 - 16.9	11.1 - 9.8	—	—	11.2 - 9.6	6.5 - 5.5	—	—	—
SB 32-2-1	5.5	7.5	—	19.2 - 16.9	11.1 - 9.8	—	—	11.2 - 9.6	6.5 - 5.5	—	—	—
SB 32-2	7.5	10.0	—	25.4 - 22.1	14.7 - 12.8	—	—	14.9 - 13.3	8.6 - 7.7	—	—	—
SB 32-3-2	11.0	15.0	—	37.0 - 33.9	21.4 - 19.6	—	—	21.5 - 20.6	12.4 - 11.9	—	—	—
SB 32-3	11.0	15.0	—	37.0 - 33.9	21.4 - 19.6	—	—	21.5 - 20.6	12.4 - 11.9	—	—	—
SB 32-4-2	11.0	15.0	—	37.0 - 33.9	21.4 - 19.6	—	—	21.5 - 20.6	12.4 - 11.9	—	—	—
SB 32-4	15.0	20.0	—	48.5 - 40.7	28.0 - 23.5	—	—	28.5 - 24.9	16.4 - 14.3	—	—	—
SB 32-5-2	15.0	20.0	—	48.5 - 40.7	28.0 - 23.5	—	—	28.5 - 24.9	16.4 - 14.3	—	—	—
SB 32-5	18.5	25.0	—	59.7 - 49.3	34.5 - 28.5	—	—	34.6 - 28.9	19.9 - 16.6	—	—	—
SB 32-6-2	18.5	25.0	—	59.7 - 49.3	34.5 - 28.5	—	—	34.6 - 28.9	19.9 - 16.6	—	—	—
SB 32-6	18.5	25.0	—	59.7 - 49.3	34.5 - 28.5	—	—	34.6 - 28.9	19.9 - 16.6	—	—	—
SB 32-7-2	22.0	30.0	—	70.4 - 58.5	40.7 - 33.8	—	—	41.1 - 34.3	23.7 - 19.8	—	—	—
SB 32-7	22.0	30.0	—	70.4 - 58.5	40.7 - 33.8	—	—	41.1 - 34.3	23.7 - 19.8	—	—	—
SB 32-8-2	30.0	40.0	—	—	—	93.3 - 85.5	54.0 - 49.5	—	—	54.0 - 49.5	31.1 - 28.5	52.1
SB 32-8	30.0	40.0	—	—	—	93.3 - 85.5	54.0 - 49.5	—	—	54.0 - 49.5	31.1 - 28.5	52.1
SB 32-9-2	30.0	40.0	—	—	—	93.3 - 85.5	54.0 - 49.5	—	—	54.0 - 49.5	31.1 - 28.5	52.1
SB 32-9	30.0	40.0	—	—	—	93.3 - 85.5	54.0 - 49.5	—	—	54.0 - 49.5	31.1 - 28.5	52.1
SB 32-10-2	30.0	40.0	—	—	—	93.3 - 85.5	54.0 - 49.5	—	—	54.0 - 49.5	31.1 - 28.5	52.1

Dimensions and Weights

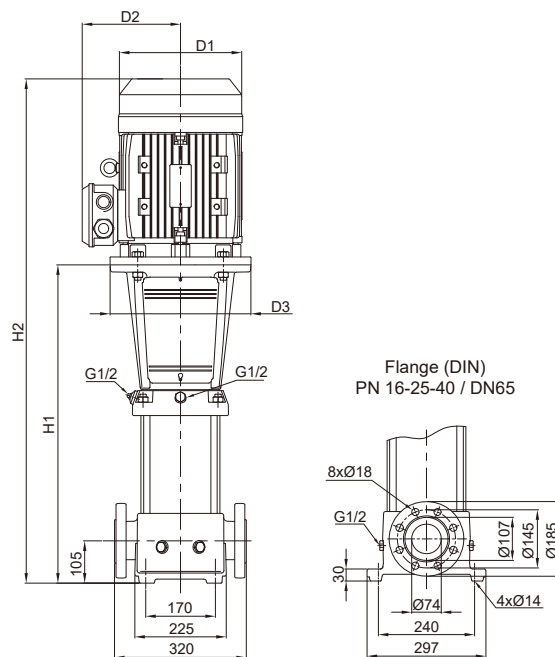

Pump Type	Dimensions (mm)					Net Weight (kg)
	DIN flange		D1	D2	D3	
	H1	H2				DIN flange
SB 32-1-1	504	799	177	141	280	74.3
SB 32-1	504	820	197	147	280	82.5
SB 32-2-2	574	936	235	197	300	106.4
SB 32-2-1	574	936	235	197	300	106.4
SB 32-2	574	979	235	197	300	112.3
SB 32-3-2	754	1199	269	215	350	151.6
SB 32-3	754	1199	269	215	350	151.6
SB 32-4-2	824	1269	269	215	350	154.7
SB 32-4	824	1314	269	215	350	165.4
SB 32-5-2	894	1384	269	215	350	168.5
SB 32-5	894	1434	318	241	350	202.3
SB 32-6-2	964	1504	318	241	350	205.3
SB 32-6	964	1504	318	241	350	205.3
SB 32-7-2	1034	1574	318	241	350	221.2
SB 32-7	1034	1574	318	241	350	221.2
SB 32-8-2	1104	1764	390	295	400	328.1
SB 32-8	1104	1764	390	295	400	328.1
SB 32-9-2	1174	1834	390	295	400	330.8
SB 32-9	1174	1834	390	295	400	330.8
SB 32-10-2	1244	1904	390	295	400	333.5

Performance Range

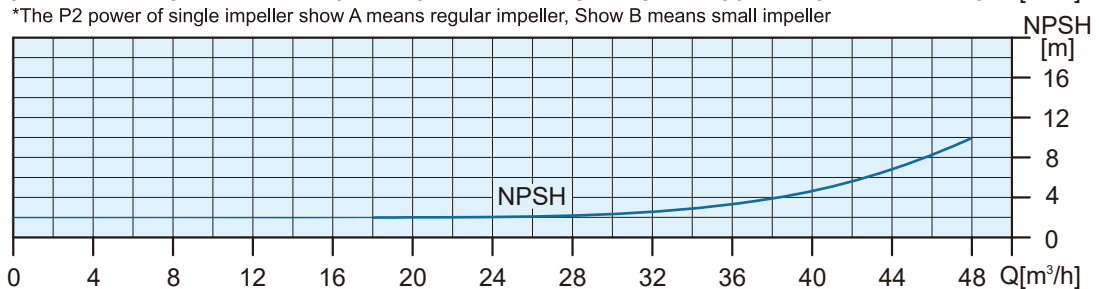
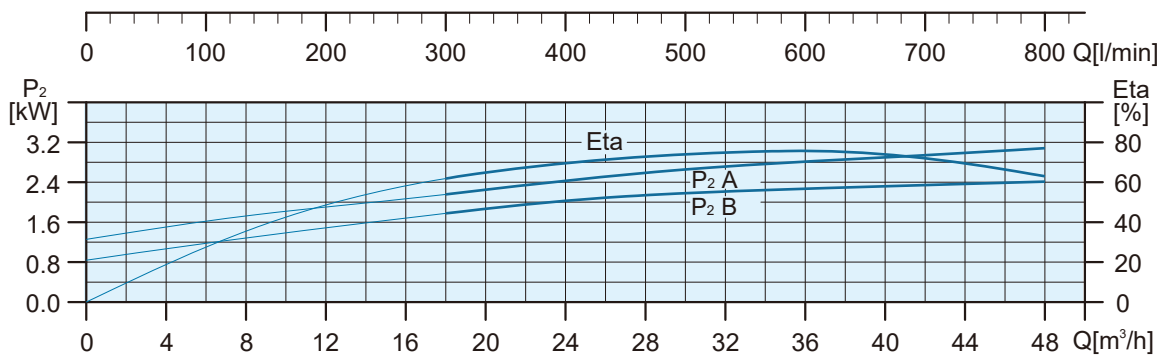
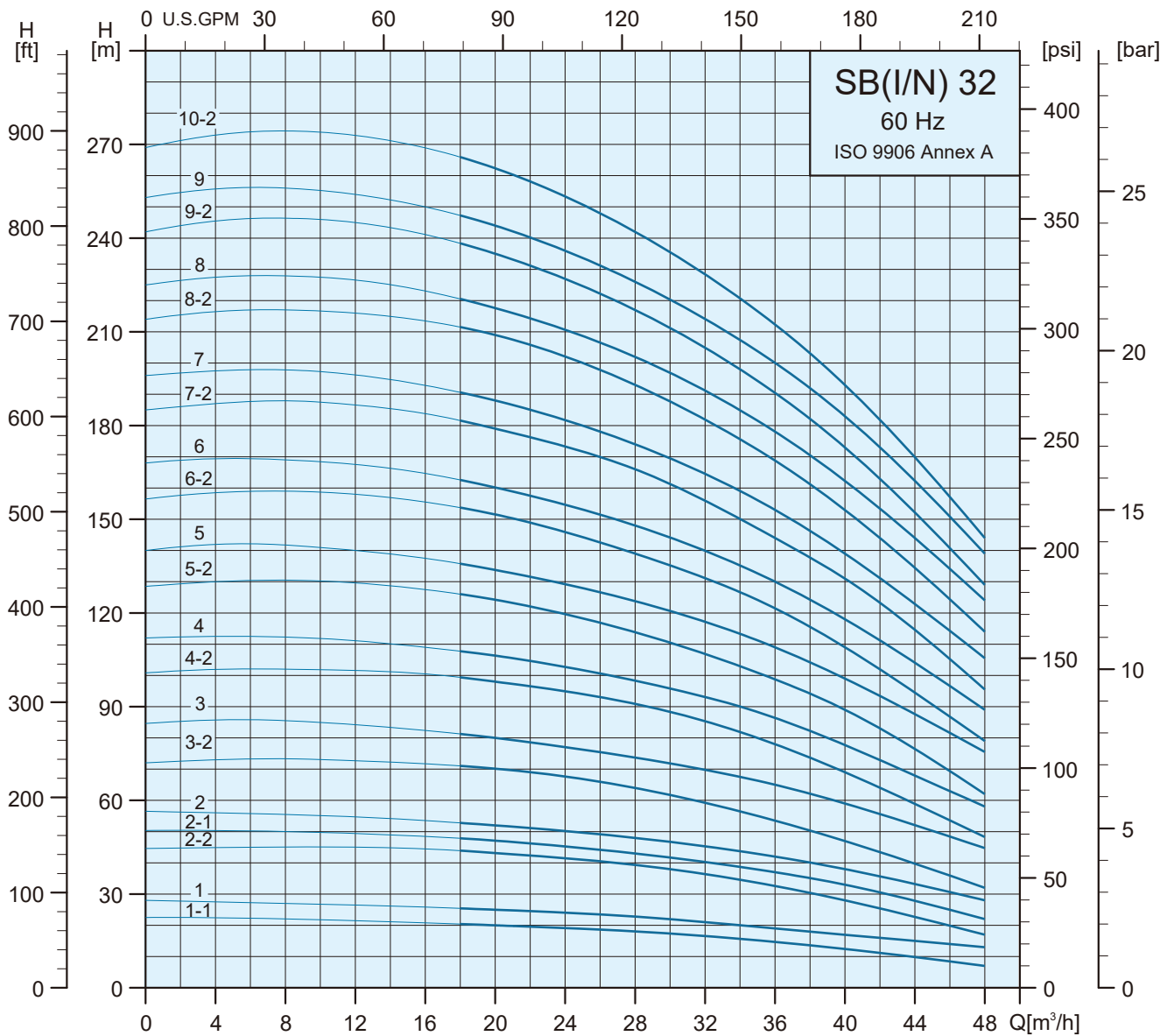

Specifications

Pump Type	Motor		Nominal Current [A]									
	P ₂		1 ϕ	3 ϕ		3 ϕ		3 ϕ		3 ϕ		
	kW	HP	220-240V	Δ 220-277V	Y380-480V	Δ 220-240V	Y380-415V	Δ 380-480V	Y660-830V	Δ 380-415V	Y660-720V	Δ 460V
SBI(N) 32-1-1	2.2	3.0	13.8 - 12.5	8.1 - 7.2	4.7 - 4.2	—	—	—	—	—	—	—
SBI(N) 32-1	3.0	4.0	—	11.1 - 9.7	6.4 - 5.6	—	—	6.6 - 5.4	3.8 - 3.1	—	—	—
SBI(N) 32-2-2	5.5	7.5	—	19.2 - 16.9	11.1 - 9.8	—	—	11.2 - 9.6	6.5 - 5.5	—	—	—
SBI(N) 32-2-1	5.5	7.5	—	19.2 - 16.9	11.1 - 9.8	—	—	11.2 - 9.6	6.5 - 5.5	—	—	—
SBI(N) 32-2	7.5	10.0	—	25.4 - 22.1	14.7 - 12.8	—	—	14.9 - 13.3	8.6 - 7.7	—	—	—
SBI(N) 32-3-2	11.0	15.0	—	37.0 - 33.9	21.4 - 19.6	—	—	21.5 - 20.6	12.4 - 11.9	—	—	—
SBI(N) 32-3	11.0	15.0	—	37.0 - 33.9	21.4 - 19.6	—	—	21.5 - 20.6	12.4 - 11.9	—	—	—
SBI(N) 32-4-2	11.0	15.0	—	37.0 - 33.9	21.4 - 19.6	—	—	21.5 - 20.6	12.4 - 11.9	—	—	—
SBI(N) 32-4	15.0	20.0	—	48.5 - 40.7	28.0 - 23.5	—	—	28.5 - 24.9	16.4 - 14.3	—	—	—
SBI(N) 32-5-2	15.0	20.0	—	48.5 - 40.7	28.0 - 23.5	—	—	28.5 - 24.9	16.4 - 14.3	—	—	—
SBI(N) 32-5	18.5	25.0	—	59.7 - 49.3	34.5 - 28.5	—	—	34.6 - 28.9	19.9 - 16.6	—	—	—
SBI(N) 32-6-2	18.5	25.0	—	59.7 - 49.3	34.5 - 28.5	—	—	34.6 - 28.9	19.9 - 16.6	—	—	—
SBI(N) 32-6	18.5	25.0	—	59.7 - 49.3	34.5 - 28.5	—	—	34.6 - 28.9	19.9 - 16.6	—	—	—
SBI(N) 32-7-2	22.0	30.0	—	70.4 - 58.5	40.7 - 33.8	—	—	41.1 - 34.3	23.7 - 19.8	—	—	—
SBI(N) 32-7	22.0	30.0	—	70.4 - 58.5	40.7 - 33.8	—	—	41.1 - 34.3	23.7 - 19.8	—	—	—
SBI(N) 32-8-2	30.0	40.0	—	—	—	93.3 - 85.5	54.0 - 49.5	—	—	54.0 - 49.5	31.1 - 28.5	52.1
SBI(N) 32-8	30.0	40.0	—	—	—	93.3 - 85.5	54.0 - 49.5	—	—	54.0 - 49.5	31.1 - 28.5	52.1
SBI(N) 32-9-2	30.0	40.0	—	—	—	93.3 - 85.5	54.0 - 49.5	—	—	54.0 - 49.5	31.1 - 28.5	52.1
SBI(N) 32-9	30.0	40.0	—	—	—	93.3 - 85.5	54.0 - 49.5	—	—	54.0 - 49.5	31.1 - 28.5	52.1
SBI(N) 32-10-2	30.0	40.0	—	—	—	93.3 - 85.5	54.0 - 49.5	—	—	54.0 - 49.5	31.1 - 28.5	52.1

Dimensions and Weights

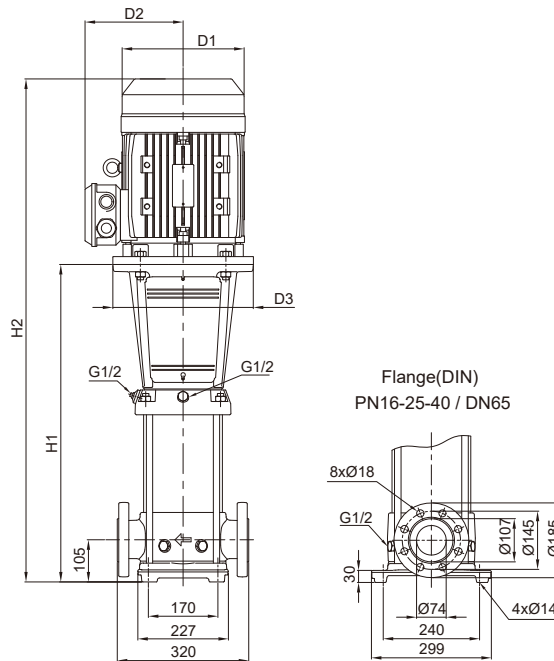

Pump Type	Dimensions (mm)					Net Weight (kg)
	DIN flange		D1	D2	D3	
	H1	H2				DIN flange
SBI(N) 32-1-1	504	799	177	141	280	69.3
SBI(N) 32-1	504	820	197	147	280	77.4
SBI(N) 32-2-2	574	936	235	197	300	101.3
SBI(N) 32-2-1	574	936	235	197	300	101.3
SBI(N) 32-2	574	979	235	197	300	107.2
SBI(N) 32-3-2	754	1199	269	215	350	146.5
SBI(N) 32-3	754	1199	269	215	350	146.5
SBI(N) 32-4-2	824	1269	269	215	350	149.6
SBI(N) 32-4	824	1314	269	215	350	160.3
SBI(N) 32-5-2	894	1384	269	215	350	163.4
SBI(N) 32-5	894	1434	318	241	350	197.3
SBI(N) 32-6-2	964	1504	318	241	350	200.4
SBI(N) 32-6	964	1504	318	241	350	200.4
SBI(N) 32-7-2	1034	1574	318	241	350	216.2
SBI(N) 32-7	1034	1574	318	241	350	216.2
SBI(N) 32-8-2	1104	1764	390	295	400	323.1
SBI(N) 32-8	1104	1764	390	295	400	323.1
SBI(N) 32-9-2	1174	1834	390	295	400	325.9
SBI(N) 32-9	1174	1834	390	295	400	325.9
SBI(N) 32-10-2	1244	1904	390	295	400	328.5

Performance Range

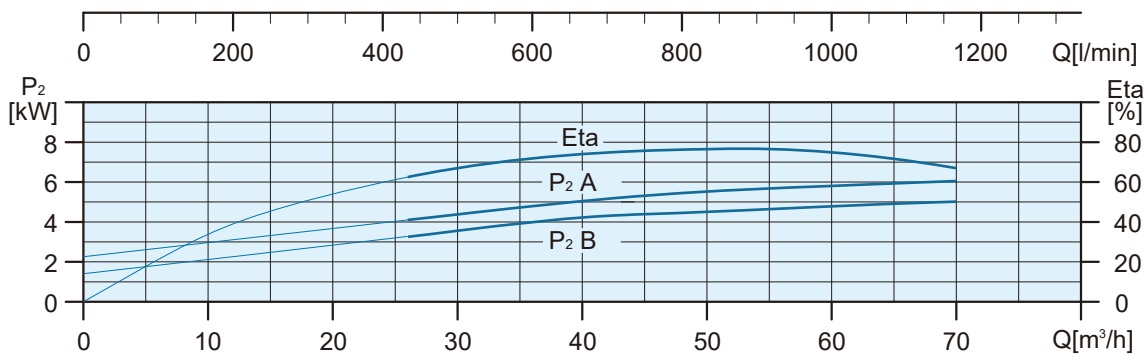
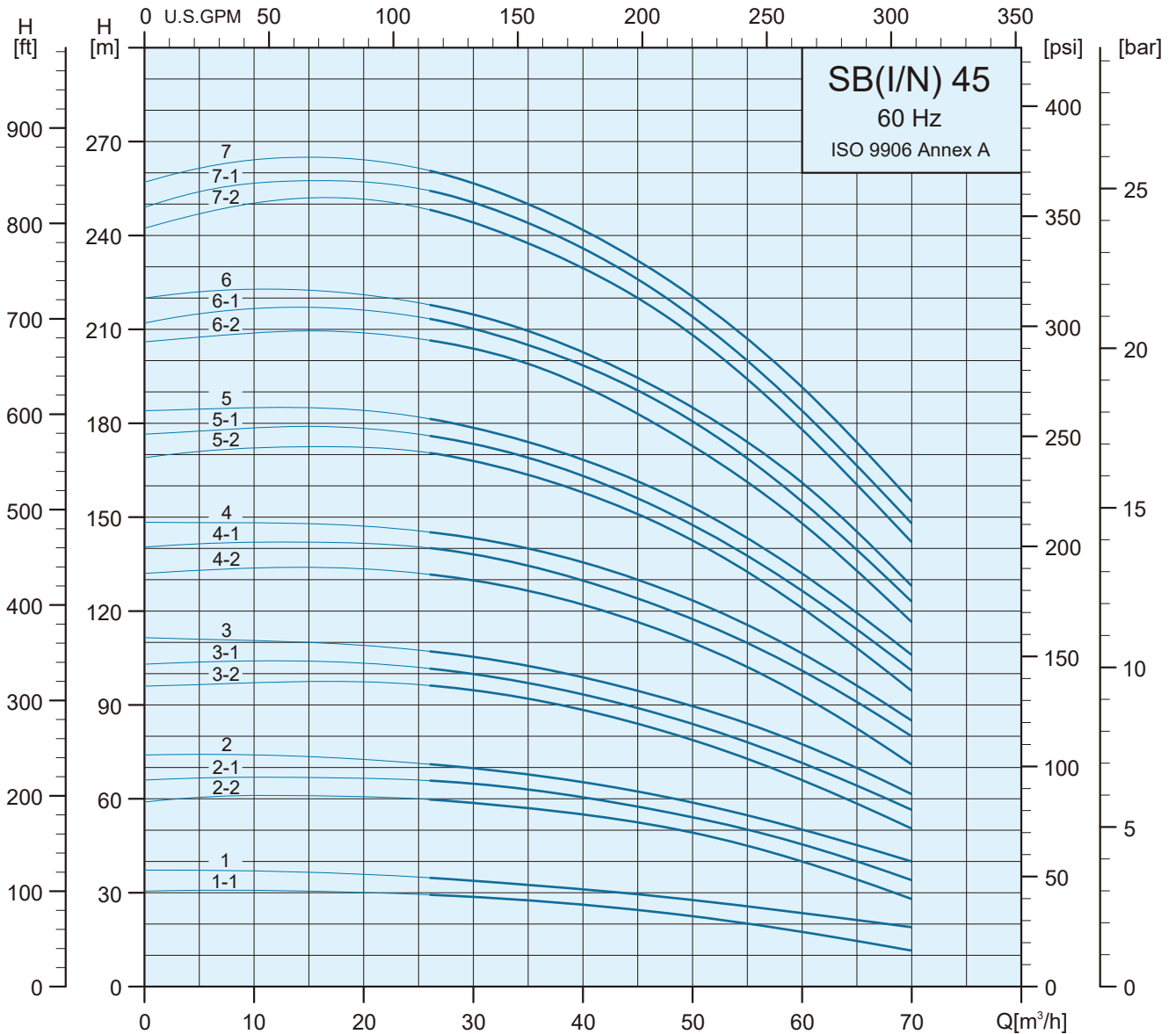

*The P₂ power of single impeller show A means regular impeller, Show B means small impeller

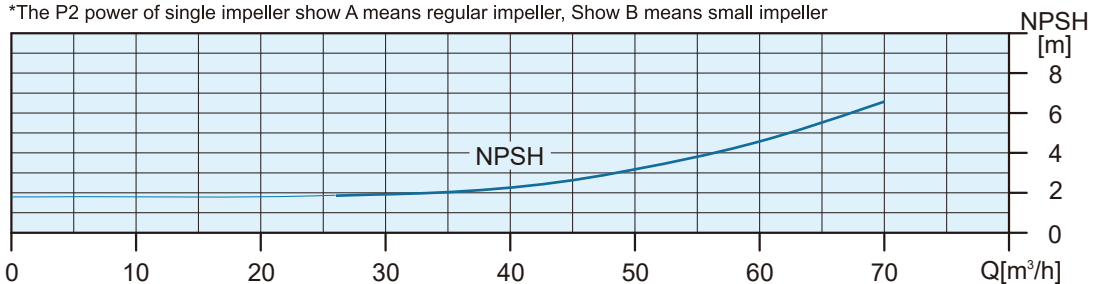

Specifications

Pump Type	Motor		Nominal Current [A]								
	P ₂		3ø		3ø		3ø		3ø		3ø
	kW	HP	Δ220-277V	Y380-480V	Δ220-240V	Y380-415V	Δ380-480V	Y660-830V	Δ380-415V	Y660-720V	Δ460V
SB 45-1-1	5.5	7.5	19.2 - 16.9	11.1 - 9.8	—	—	11.2 - 9.6	6.5 - 5.5	—	—	—
SB 45-1	7.5	10.0	25.4 - 22.1	14.7 - 12.8	—	—	14.9 - 13.3	8.6 - 7.7	—	—	—
SB 45-2-2	11.0	15.0	37.0 - 33.9	21.4 - 19.6	—	—	21.5 - 20.6	12.4 - 11.9	—	—	—
SB 45-2-1	11.0	15.0	37.0 - 33.9	21.4 - 19.6	—	—	21.5 - 20.6	12.4 - 11.9	—	—	—
SB 45-2	15.0	20.0	48.5 - 40.7	28.0 - 23.5	—	—	28.5 - 24.9	16.4 - 14.3	—	—	—
SB 45-3-2	18.5	25.0	59.7 - 49.3	34.5 - 28.5	—	—	34.6 - 28.9	19.9 - 16.6	—	—	—
SB 45-3-1	18.5	25.0	59.7 - 49.3	34.5 - 28.5	—	—	34.6 - 28.9	19.9 - 16.6	—	—	—
SB 45-3	18.5	25.0	59.7 - 49.3	34.5 - 28.5	—	—	34.6 - 28.9	19.9 - 16.6	—	—	—
SB 45-4-2	22.0	30.0	70.4 - 58.5	40.7 - 33.8	—	—	41.1 - 34.3	23.7 - 19.8	—	—	—
SB 45-4-1	30.0	40.0	—	—	93.3 - 85.5	54.0 - 49.5	—	—	54.0 - 49.5	31.1 - 28.5	52.1
SB 45-4	30.0	40.0	—	—	93.3 - 85.5	54.0 - 49.5	—	—	54.0 - 49.5	31.1 - 28.5	52.1
SB 45-5-2	30.0	40.0	—	—	93.3 - 85.5	54.0 - 49.5	—	—	54.0 - 49.5	31.1 - 28.5	52.1
SB 45-5-1	30.0	40.0	—	—	93.3 - 85.5	54.0 - 49.5	—	—	54.0 - 49.5	31.1 - 28.5	52.1
SB 45-5	30.0	40.0	—	—	93.3 - 85.5	54.0 - 49.5	—	—	54.0 - 49.5	31.1 - 28.5	52.1
SB 45-6-2	37.0	50.0	—	—	113.0 - 103.6	65.0 - 59.5	—	—	65.0 - 59.5	37.0 - 33.9	64.0
SB 45-6-1	37.0	50.0	—	—	113.0 - 103.6	65.0 - 59.5	—	—	65.0 - 59.5	37.0 - 33.9	64.0
SB 45-6	37.0	50.0	—	—	113.0 - 103.6	65.0 - 59.5	—	—	65.0 - 59.5	37.0 - 33.9	64.0
SB 45-7-2	45.0	60.0	—	—	137.0 - 125.6	79.0 - 72.3	—	—	79.0 - 72.3	45.0 - 41.3	77.6
SB 45-7-1	45.0	60.0	—	—	137.0 - 125.6	79.0 - 72.3	—	—	79.0 - 72.3	45.0 - 41.3	77.6
SB 45-7	45.0	60.0	—	—	137.0 - 125.6	79.0 - 72.3	—	—	79.0 - 72.3	45.0 - 41.3	77.6

Dimensions and Weights

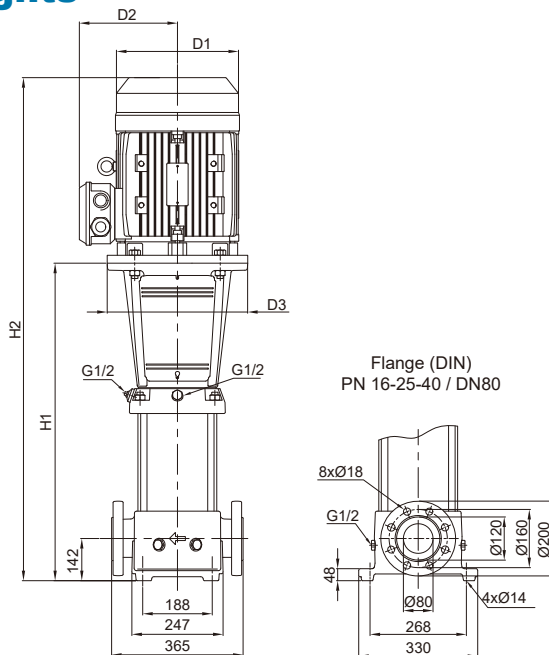

Pump Type	Dimensions (mm)					Net Weight (kg)
	DIN flange		D1	D2	D3	
	H1	H2				DIN flange
SB 45-1-1	561	923	235	197	300	113.9
SB 45-1	561	966	235	197	300	119.8
SB 45-2-2	751	1196	269	215	350	159.7
SB 45-2-1	751	1196	269	215	350	159.7
SB 45-2	751	1241	269	215	350	170.4
SB 45-3-2	831	1371	318	241	350	208.0
SB 45-3-1	831	1371	318	241	350	208.0
SB 45-3	831	1371	318	241	350	208.0
SB 45-4-2	911	1451	318	241	350	224.5
SB 45-4-1	911	1571	390	295	400	328.1
SB 45-4	911	1571	390	295	400	328.1
SB 45-5-2	991	1651	390	295	400	331.9
SB 45-5-1	991	1651	390	295	400	331.9
SB 45-5	991	1651	390	295	400	331.9
SB 45-6-2	1071	1731	390	295	400	353.7
SB 45-6-1	1071	1731	390	295	400	353.7
SB 45-6	1071	1731	390	295	400	353.7
SB 45-7-2	1151	1841	446	325	450	433.6
SB 45-7-1	1151	1841	446	325	450	433.6
SB 45-7	1151	1841	446	325	450	433.6

Performance Range

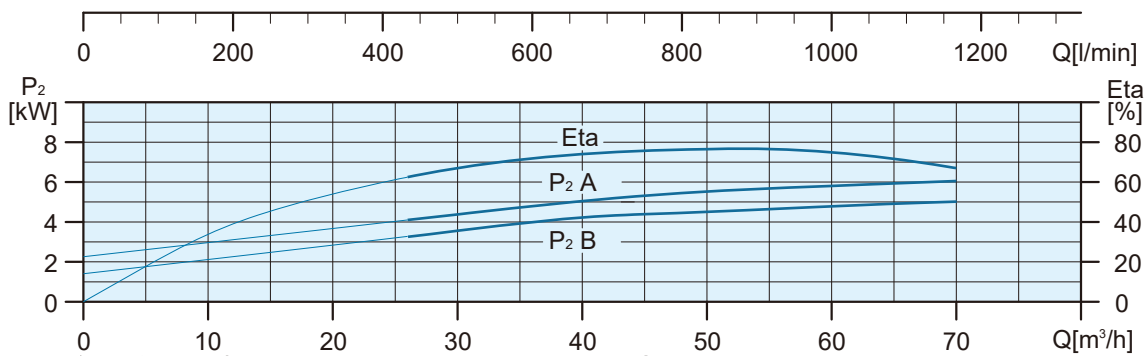
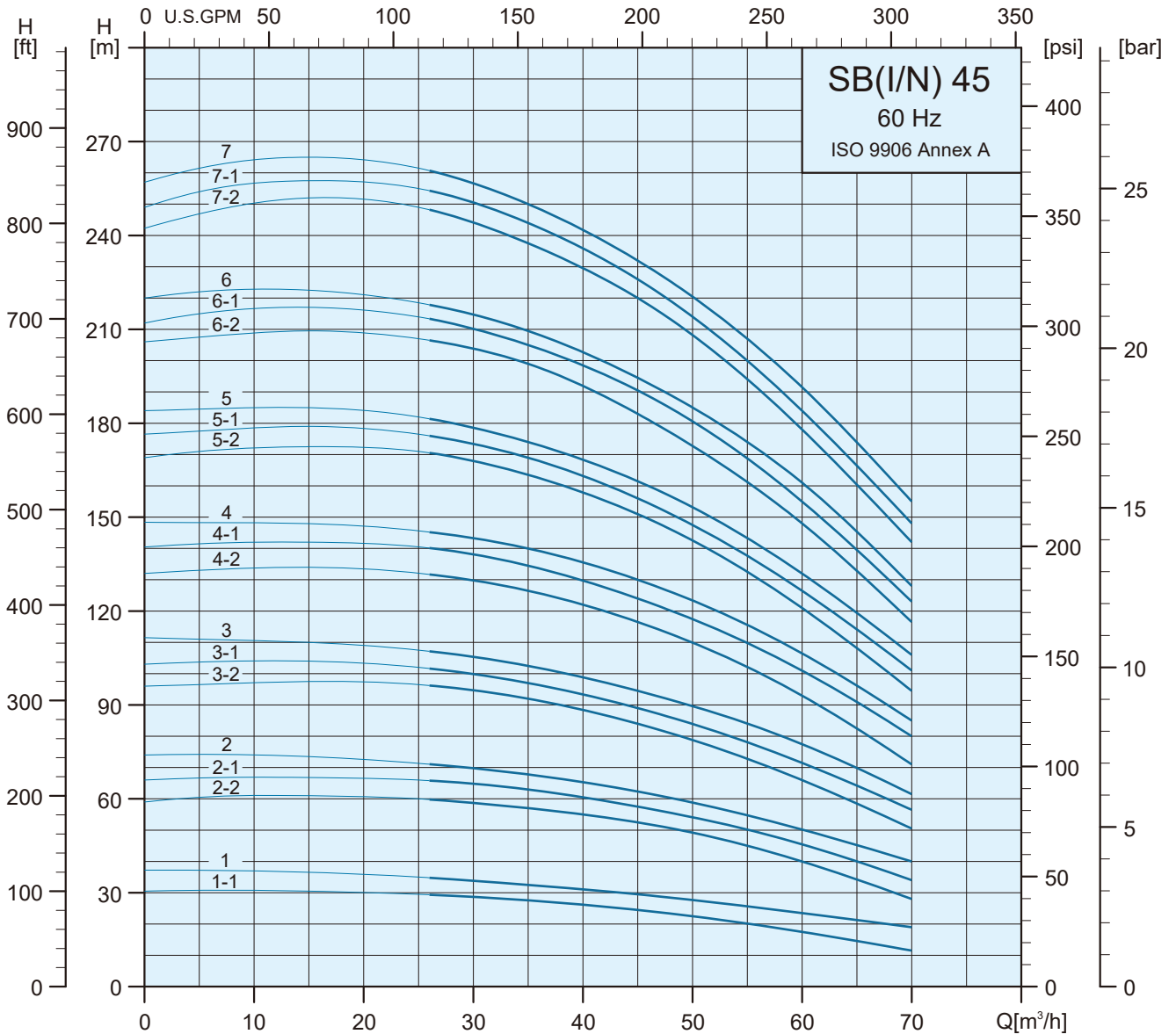

*The P₂ power of single impeller show A means regular impeller, Show B means small impeller

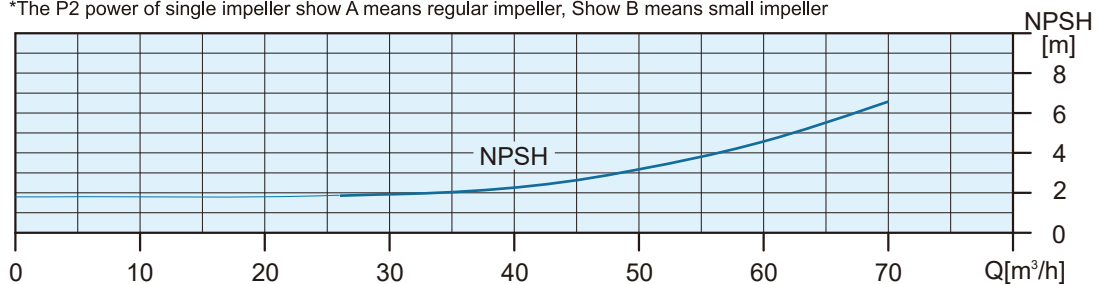

Specifications

Pump Type	Motor		Nominal Current [A]								
	P ₂		3ø		3ø		3ø		3ø		3ø
	kW	HP	△220-277V	Y380-480V	△220-240V	Y380-415V	△380-480V	Y660-830V	△380-415V	Y660-720V	△460V
SBI(N) 45-1-1	5.5	7.5	19.2 - 16.9	11.1 - 9.8	—	—	11.2 - 9.6	6.5 - 5.5	—	—	—
SBI(N) 45-1	7.5	10.0	25.4 - 22.1	14.7 - 12.8	—	—	14.9 - 13.3	8.6 - 7.7	—	—	—
SBI(N) 45-2-2	11.0	15.0	37.0 - 33.9	21.4 - 19.6	—	—	21.5 - 20.6	12.4 - 11.9	—	—	—
SBI(N) 45-2-1	11.0	15.0	37.0 - 33.9	21.4 - 19.6	—	—	21.5 - 20.6	12.4 - 11.9	—	—	—
SBI(N) 45-2	15.0	20.0	48.5 - 40.7	28.0 - 23.5	—	—	28.5 - 24.9	16.4 - 14.3	—	—	—
SBI(N) 45-3-2	18.5	25.0	59.7 - 49.3	34.5 - 28.5	—	—	34.6 - 28.9	19.9 - 16.6	—	—	—
SBI(N) 45-3-1	18.5	25.0	59.7 - 49.3	34.5 - 28.5	—	—	34.6 - 28.9	19.9 - 16.6	—	—	—
SBI(N) 45-3	18.5	25.0	59.7 - 49.3	34.5 - 28.5	—	—	34.6 - 28.9	19.9 - 16.6	—	—	—
SBI(N) 45-4-2	22.0	30.0	70.4 - 58.5	40.7 - 33.8	—	—	41.1 - 34.3	23.7 - 19.8	—	—	—
SBI(N) 45-4-1	30.0	40.0	—	—	93.3 - 85.5	54.0 - 49.5	—	—	54.0 - 49.5	31.1 - 28.5	52.1
SBI(N) 45-4	30.0	40.0	—	—	93.3 - 85.5	54.0 - 49.5	—	—	54.0 - 49.5	31.1 - 28.5	52.1
SBI(N) 45-5-2	30.0	40.0	—	—	93.3 - 85.5	54.0 - 49.5	—	—	54.0 - 49.5	31.1 - 28.5	52.1
SBI(N) 45-5-1	30.0	40.0	—	—	93.3 - 85.5	54.0 - 49.5	—	—	54.0 - 49.5	31.1 - 28.5	52.1
SBI(N) 45-5	30.0	40.0	—	—	93.3 - 85.5	54.0 - 49.5	—	—	54.0 - 49.5	31.1 - 28.5	52.1
SBI(N) 45-6-2	37.0	50.0	—	—	113.0 - 103.6	65.0 - 59.5	—	—	65.0 - 59.5	37.0 - 33.9	64.0
SBI(N) 45-6-1	37.0	50.0	—	—	113.0 - 103.6	65.0 - 59.5	—	—	65.0 - 59.5	37.0 - 33.9	64.0
SBI(N) 45-6	37.0	50.0	—	—	113.0 - 103.6	65.0 - 59.5	—	—	65.0 - 59.5	37.0 - 33.9	64.0
SBI(N) 45-7-2	45.0	60.0	—	—	137.0 - 125.6	79.0 - 72.3	—	—	79.0 - 72.3	45.0 - 41.3	77.6
SBI(N) 45-7-1	45.0	60.0	—	—	137.0 - 125.6	79.0 - 72.3	—	—	79.0 - 72.3	45.0 - 41.3	77.6
SBI(N) 45-7	45.0	60.0	—	—	137.0 - 125.6	79.0 - 72.3	—	—	79.0 - 72.3	45.0 - 41.3	77.6

Dimensions and Weights

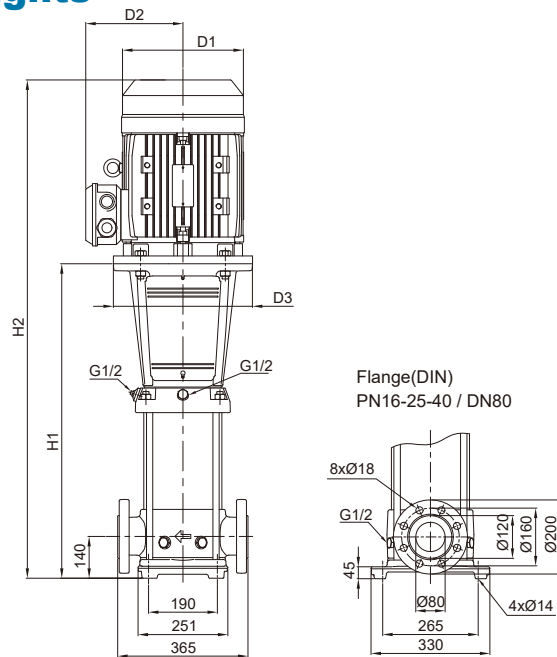

Pump Type	Dimensions (mm)						Net Weight (kg)
	DIN flange		D1	D2	D3	DIN flange	
	H1	H2					
SBI(N) 45-1-1	559	921	235	197	300	105.1	
SBI(N) 45-1	559	964	235	197	300	111.0	
SBI(N) 45-2-2	749	1194	269	215	350	150.9	
SBI(N) 45-2-1	749	1194	269	215	350	150.9	
SBI(N) 45-2	749	1239	269	215	350	161.6	
SBI(N) 45-3-2	829	1369	318	241	350	199.2	
SBI(N) 45-3-1	829	1369	318	241	350	199.2	
SBI(N) 45-3	829	1369	318	241	350	199.2	
SBI(N) 45-4-2	909	1449	318	241	350	215.7	
SBI(N) 45-4-1	909	1569	390	295	400	319.3	
SBI(N) 45-4	909	1569	390	295	400	319.3	
SBI(N) 45-5-2	989	1649	390	295	400	323.1	
SBI(N) 45-5-1	989	1649	390	295	400	323.1	
SBI(N) 45-5	989	1649	390	295	400	323.1	
SBI(N) 45-6-2	1069	1729	390	295	400	344.9	
SBI(N) 45-6-1	1069	1729	390	295	400	344.9	
SBI(N) 45-6	1069	1729	390	295	400	344.9	
SBI(N) 45-7-2	1149	1839	446	325	450	424.8	
SBI(N) 45-7-1	1149	1839	446	325	450	424.8	
SBI(N) 45-7	1149	1839	446	325	450	424.8	

Performance Range

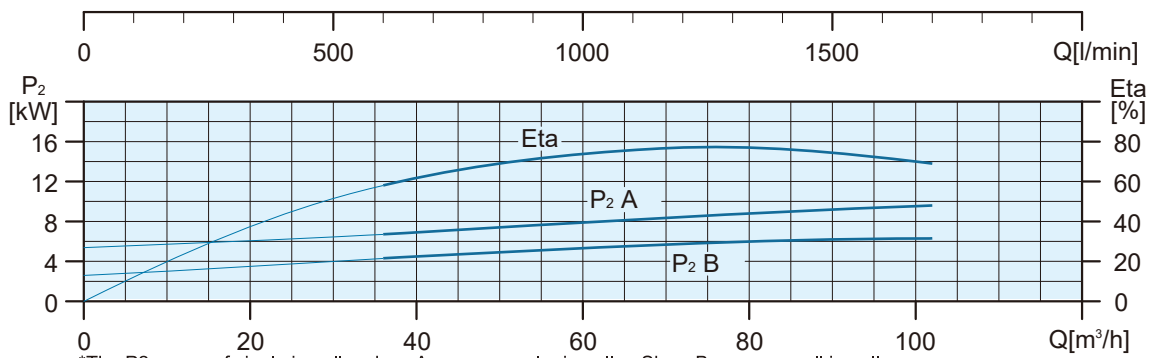
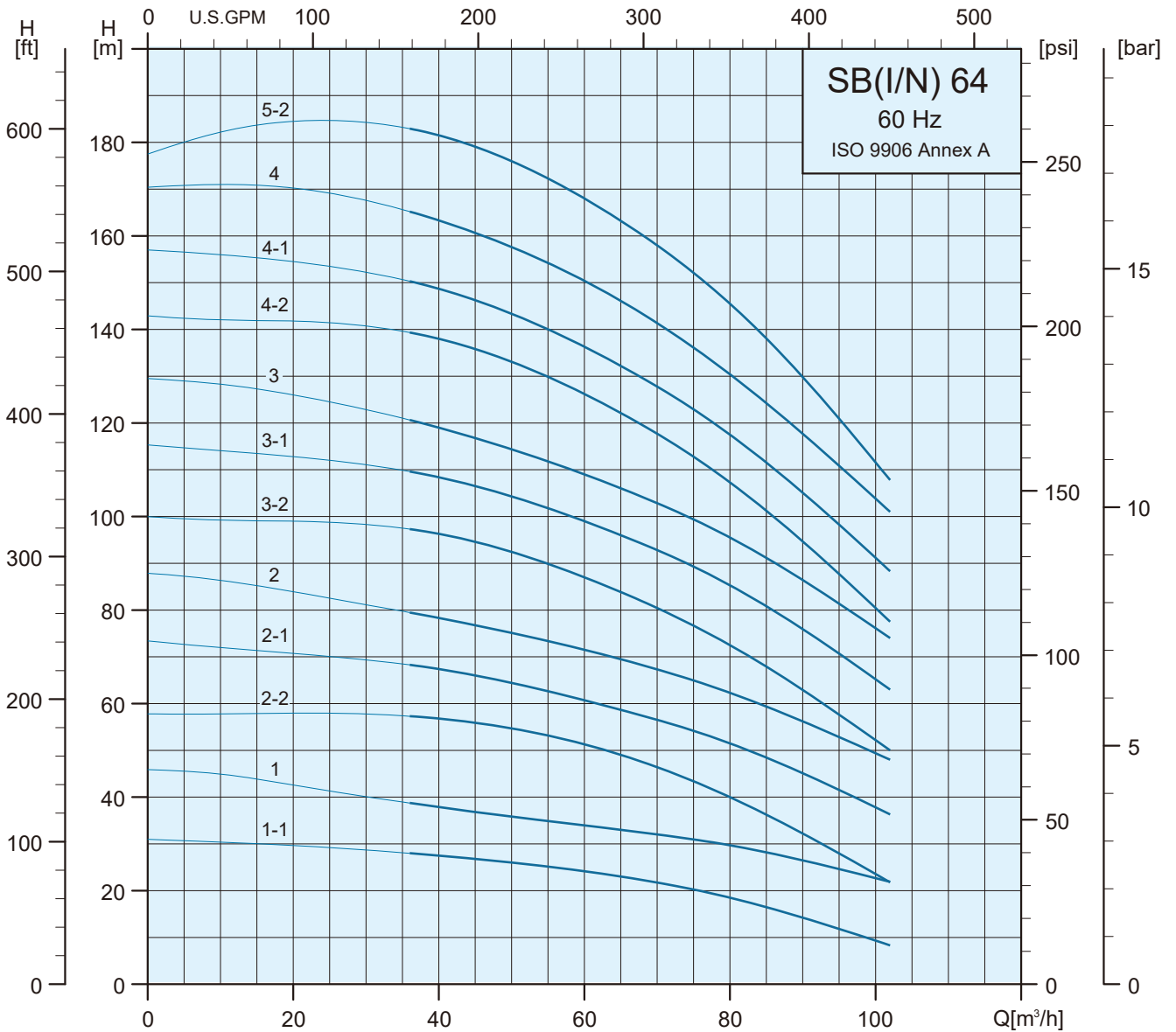

*The P₂ power of single impeller show A means regular impeller, Show B means small impeller

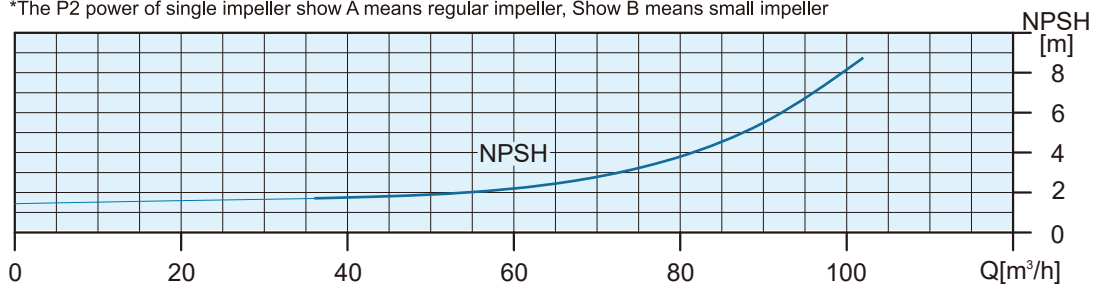

Specifications

Pump Type	Motor		Nominal Current [A]								
	P ₂		3 ϕ		3 ϕ		3 ϕ		3 ϕ		3 ϕ
	kW	HP	Δ 220-277V	Y380-480V	Δ 220-240V	Y380-415V	Δ 380-480V	Y660-830V	Δ 380-415V	Y660-720V	Δ 460V
SB 64-1-1	7.5	10.0	25.4 - 22.1	14.7 - 12.8	—	—	14.9 - 13.3	8.6 - 7.7	—	—	—
SB 64-1	11.0	15.0	37.0 - 33.9	21.4 - 19.6	—	—	21.5 - 20.6	12.4 - 11.9	—	—	—
SB 64-2-2	15.0	20.0	48.5 - 40.7	28.0 - 23.5	—	—	28.5 - 24.9	16.4 - 14.3	—	—	—
SB 64-2-1	18.5	25.0	59.7 - 49.3	34.5 - 28.5	—	—	34.6 - 28.9	19.9 - 16.6	—	—	—
SB 64-2	22.0	30.0	70.4 - 58.5	40.7 - 33.8	—	—	41.1 - 34.3	23.7 - 19.8	—	—	—
SB 64-3-2	22.0	30.0	70.4 - 58.5	40.7 - 33.8	—	—	41.1 - 34.3	23.7 - 19.8	—	—	—
SB 64-3-1	30.0	40.0	—	—	93.3 - 85.5	54.0 - 49.5	—	—	54.0 - 49.5	31.1 - 28.5	52.1
SB 64-3	30.0	40.0	—	—	93.3 - 85.5	54.0 - 49.5	—	—	54.0 - 49.5	31.1 - 28.5	52.1
SB 64-4-2	37.0	50.0	—	—	113.0 - 103.6	65.0 - 59.5	—	—	65.0 - 59.5	37.0 - 33.9	64.0
SB 64-4-1	37.0	50.0	—	—	113.0 - 103.6	65.0 - 59.5	—	—	65.0 - 59.5	37.0 - 33.9	64.0
SB 64-4	45.0	60.0	—	—	137.0 - 125.6	79.0 - 72.3	—	—	79.0 - 72.3	45.0 - 41.3	77.6
SB 64-5-2	45.0	60.0	—	—	137.0 - 125.6	79.0 - 72.3	—	—	79.0 - 72.3	45.0 - 41.3	77.6

Dimensions and Weights

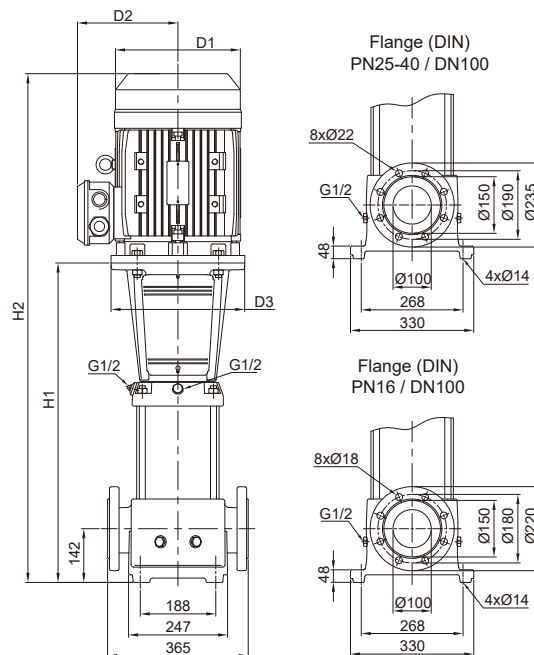

Pump Type	Dimensions (mm)					Net Weight (kg)
	DIN flange		D1	D2	D3	
	H1	H2				
SB 64-1-1	563	968	235	197	300	113.5
SB 64-1	673	1118	269	215	350	149.7
SB 64-2-2	756	1246	269	215	350	164.5
SB 64-2-1	756	1296	318	241	350	198.3
SB 64-2	756	1296	318	241	350	211.0
SB 64-3-2	838	1378	318	241	350	215.6
SB 64-3-1	838	1498	390	295	400	319.2
SB 64-3	838	1498	390	295	400	319.2
SB 64-4-2	921	1581	390	295	400	341.2
SB 64-4-1	921	1581	390	295	400	341.2
SB 64-4	925	1615	446	325	450	417.4
SB 64-5-2	1007	1697	446	325	450	421.4

Performance Range

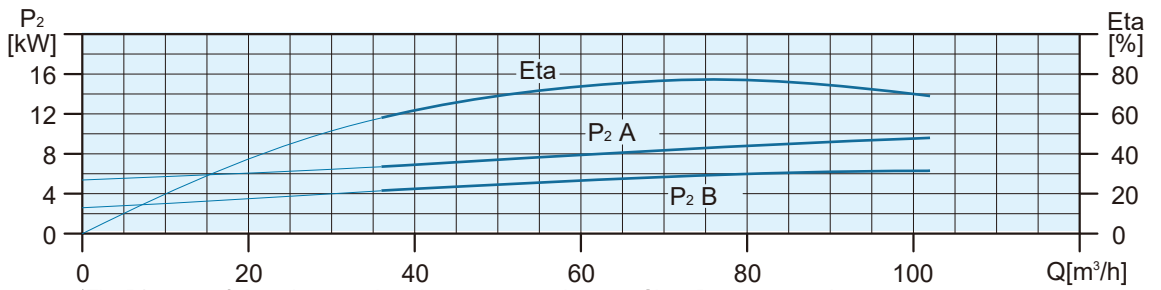
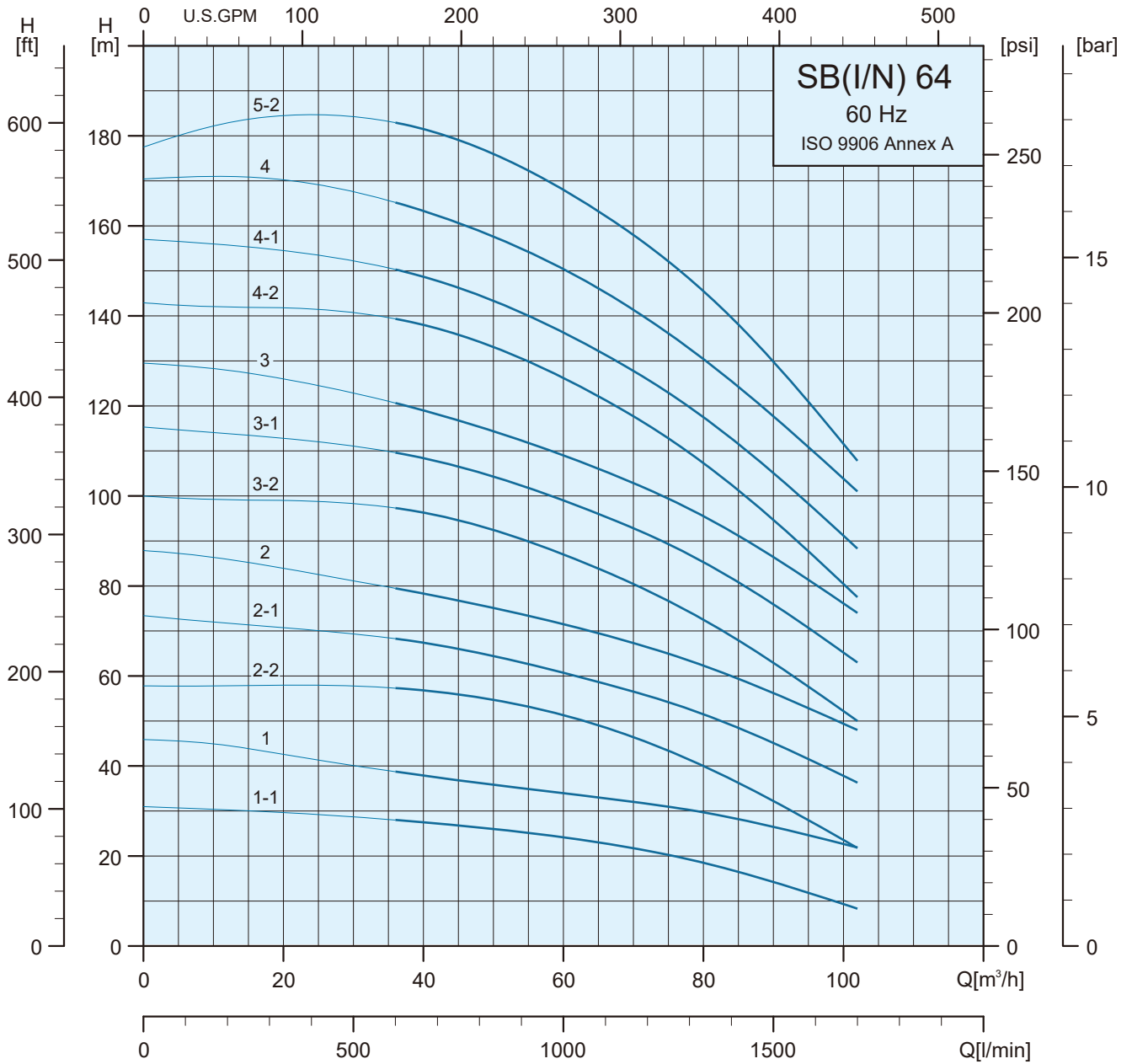

*The P2 power of single impeller show A means regular impeller, Show B means small impeller

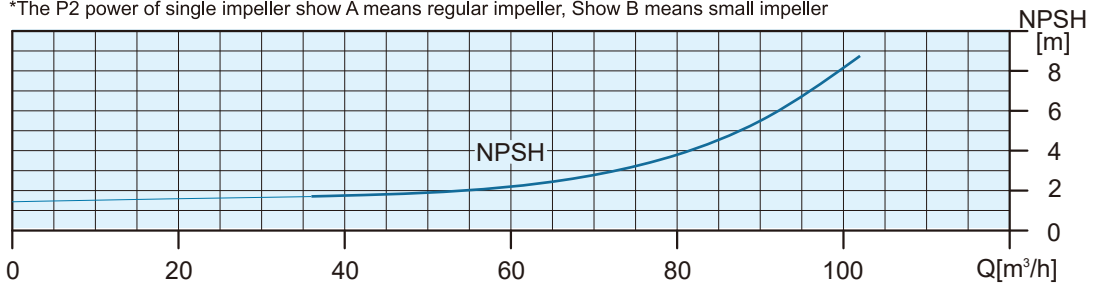

Specifications

Pump Type	Motor		Nominal Current [A]								
	P ₂		3 ϕ		3 ϕ		3 ϕ		3 ϕ		3 ϕ
	kW	HP	Δ 220-277V	Y380-480V	Δ 220-240V	Y380-415V	Δ 380-480V	Y660-830V	Δ 380-415V	Y660-720V	Δ 460V
SBI(N) 64-1-1	7.5	10.0	25.4 - 22.1	14.7 - 12.8	—	—	14.9 - 13.3	8.6 - 7.7	—	—	—
SBI(N) 64-1	11.0	15.0	37.0 - 33.9	21.4 - 19.6	—	—	21.5 - 20.6	12.4 - 11.9	—	—	—
SBI(N) 64-2-2	15.0	20.0	48.5 - 40.7	28.0 - 23.5	—	—	28.5 - 24.9	16.4 - 14.3	—	—	—
SBI(N) 64-2-1	18.5	25.0	59.7 - 49.3	34.5 - 28.5	—	—	34.6 - 28.9	19.9 - 16.6	—	—	—
SBI(N) 64-2	22.0	30.0	70.4 - 58.5	40.7 - 33.8	—	—	41.1 - 34.3	23.7 - 19.8	—	—	—
SBI(N) 64-3-2	22.0	30.0	70.4 - 58.5	40.7 - 33.8	—	—	41.1 - 34.3	23.7 - 19.8	—	—	—
SBI(N) 64-3-1	30.0	40.0	—	—	93.3 - 85.5	54.0 - 49.5	—	—	54.0 - 49.5	31.1 - 28.5	52.1
SBI(N) 64-3	30.0	40.0	—	—	93.3 - 85.5	54.0 - 49.5	—	—	54.0 - 49.5	31.1 - 28.5	52.1
SBI(N) 64-4-2	37.0	50.0	—	—	113.0 - 103.6	65.0 - 59.5	—	—	65.0 - 59.5	37.0 - 33.9	64.0
SBI(N) 64-4-1	37.0	50.0	—	—	113.0 - 103.6	65.0 - 59.5	—	—	65.0 - 59.5	37.0 - 33.9	64.0
SBI(N) 64-4	45.0	60.0	—	—	137.0 - 125.6	79.0 - 72.3	—	—	79.0 - 72.3	45.0 - 41.3	77.6
SBI(N) 64-5-2	45.0	60.0	—	—	137.0 - 125.6	79.0 - 72.3	—	—	79.0 - 72.3	45.0 - 41.3	77.6

Dimensions and Weights

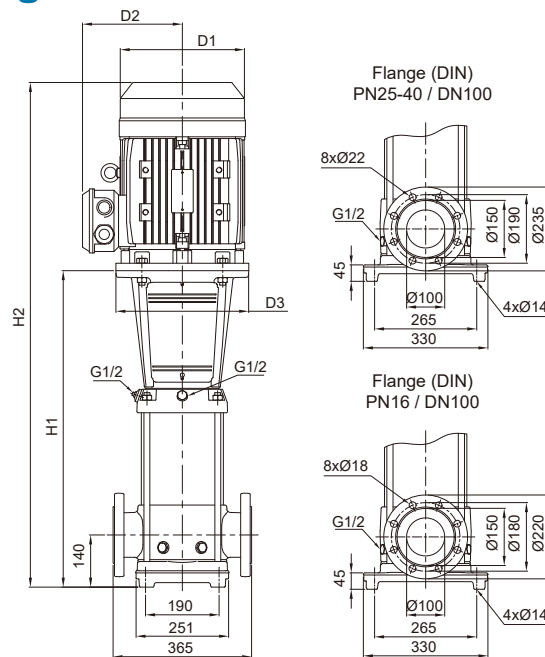

Pump Type	Dimensions (mm)					Net Weight (kg)
	DIN flange		D1	D2	D3	
	H1	H2				DIN flange
SBI(N) 64-1-1	563	968	235	197	300	106.5
SBI(N) 64-1	673	1118	269	215	350	142.7
SBI(N) 64-2-2	756	1246	269	215	350	157.5
SBI(N) 64-2-1	756	1296	318	241	350	191.3
SBI(N) 64-2	756	1296	318	241	350	204.0
SBI(N) 64-3-2	838	1378	318	241	350	208.1
SBI(N) 64-3-1	838	1498	390	295	400	311.7
SBI(N) 64-3	838	1498	390	295	400	311.7
SBI(N) 64-4-2	921	1581	390	295	400	333.7
SBI(N) 64-4-1	921	1581	390	295	400	333.7
SBI(N) 64-4	925	1615	446	325	450	409.8
SBI(N) 64-5-2	1007	1697	446	325	450	413.8

Performance Range

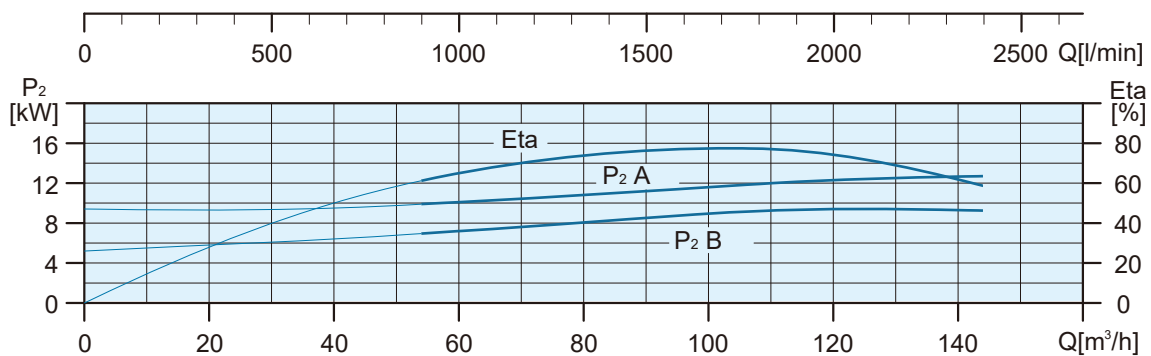
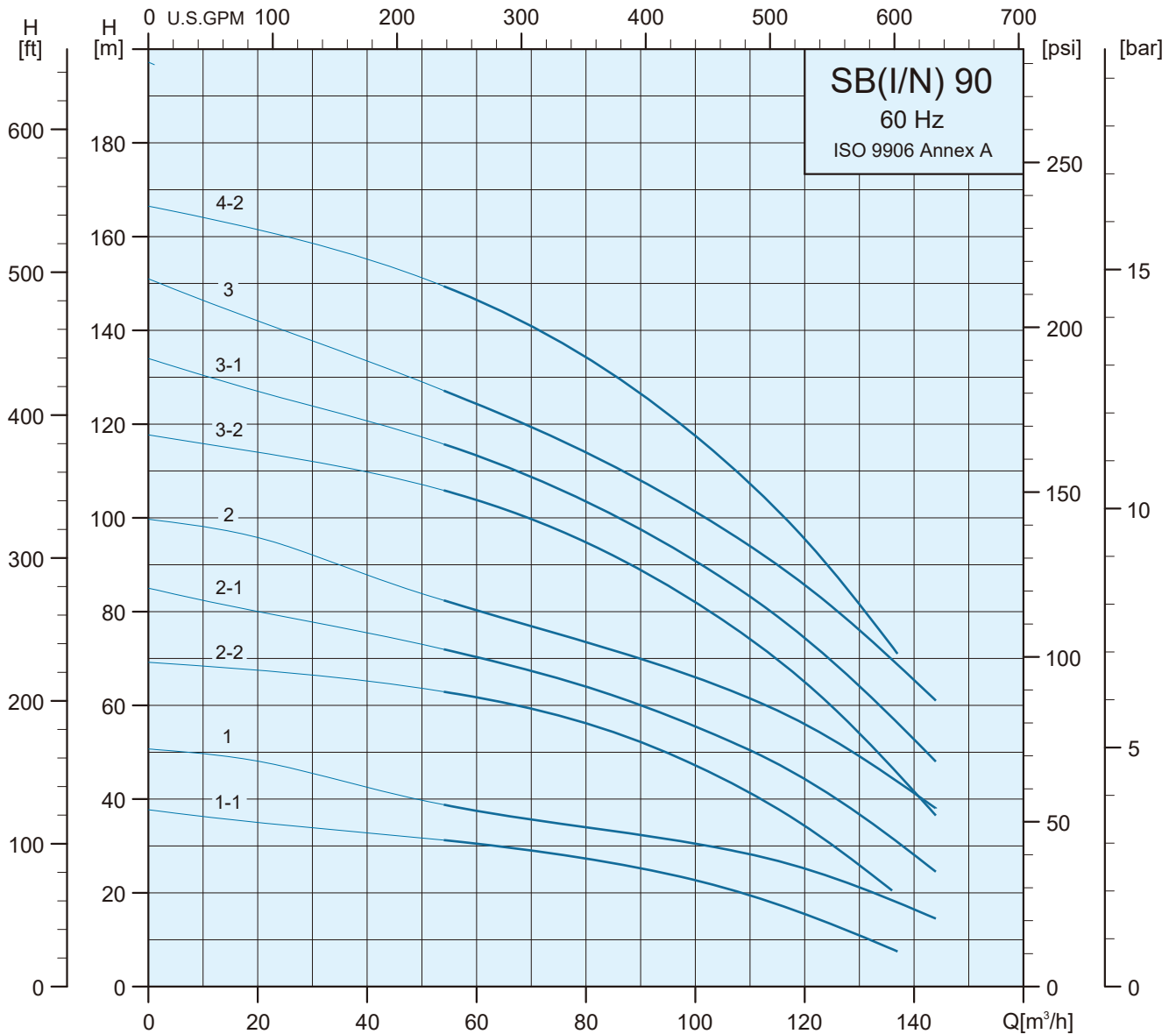

*The P₂ power of single impeller show A means regular impeller, Show B means small impeller

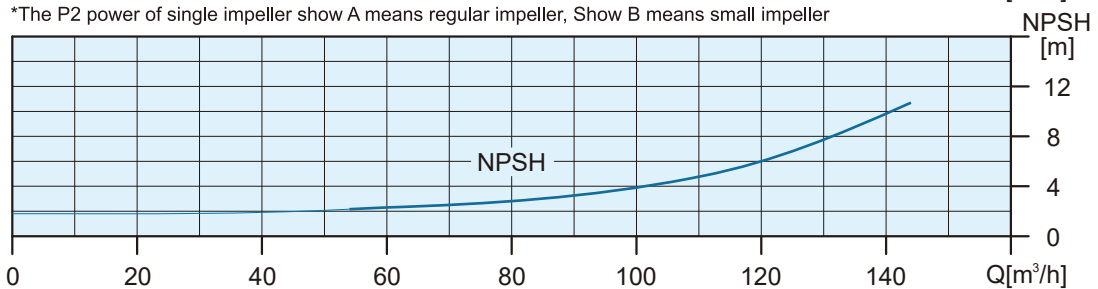

Specifications

Pump Type	Motor		Nominal Current [A]								
	P ₂		3 ϕ		3 ϕ		3 ϕ		3 ϕ		3 ϕ
	kW	HP	Δ 220-277V	Y380-480V	Δ 220-240V	Y380-415V	Δ 380-480V	Y660-830V	Δ 380-415V	Y660-720V	Δ 460V
SB 90-1-1	11.0	15.0	37.0 - 33.9	21.4 - 19.6	—	—	21.5 - 20.6	12.4 - 11.9	—	—	—
SB 90-1	15.0	20.0	48.5 - 40.7	28.0 - 23.5	—	—	28.5 - 24.9	16.4 - 14.3	—	—	—
SB 90-2-2	18.5	25.0	59.7 - 49.3	34.5 - 28.5	—	—	34.6 - 28.9	19.9 - 16.6	—	—	—
SB 90-2-1	22.0	30.0	70.4 - 58.5	40.7 - 33.8	—	—	41.1 - 34.3	23.7 - 19.8	—	—	—
SB 90-2	30.0	40.0	—	—	93.3 - 85.5	54.0 - 49.5	—	—	54.0 - 49.5	31.1 - 28.5	52.1
SB 90-3-2	37.0	50.0	—	—	113.0 - 103.6	65.0 - 59.5	—	—	65.0 - 59.5	37.0 - 33.9	64.0
SB 90-3-1	37.0	50.0	—	—	113.0 - 103.6	65.0 - 59.5	—	—	65.0 - 59.5	37.0 - 33.9	64.0
SB 90-3	45.0	60.0	—	—	137.0 - 125.6	79.0 - 72.3	—	—	79.0 - 72.3	45.0 - 41.3	77.6
SB 90-4-2	45.0	60.0	—	—	137.0 - 125.6	79.0 - 72.3	—	—	79.0 - 72.3	45.0 - 41.3	77.6

Dimensions and Weights

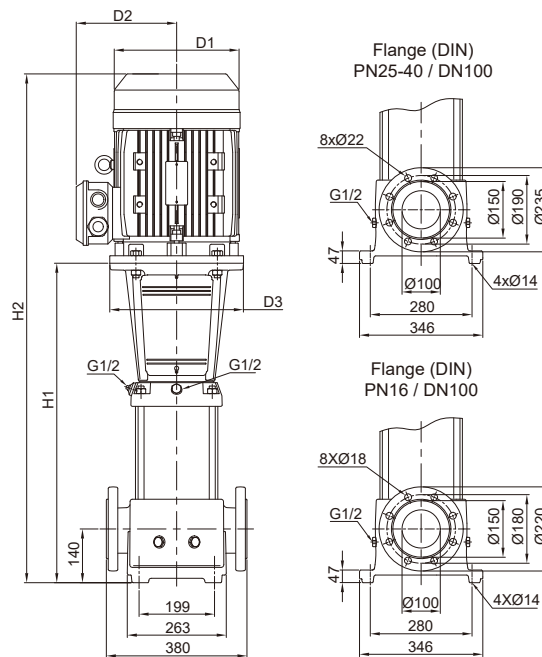

Pump Type	Dimensions (mm)					Net Weight (kg)
	DIN flange		D1	D2	D3	
	H1	H2				DIN flange
SB 90-1-1	682	1127	269	215	350	157.1
SB 90-1	682	1172	269	215	350	167.7
SB 90-2-2	774	1314	318	241	350	207.0
SB 90-2-1	774	1314	318	241	350	219.7
SB 90-2	774	1434	390	295	400	323.3
SB 90-3-2	866	1526	390	295	400	346.6
SB 90-3-1	866	1526	390	295	400	346.6
SB 90-3	866	1556	446	325	450	422.7
SB 90-4-2	958	1648	446	325	450	427.9

Performance Range

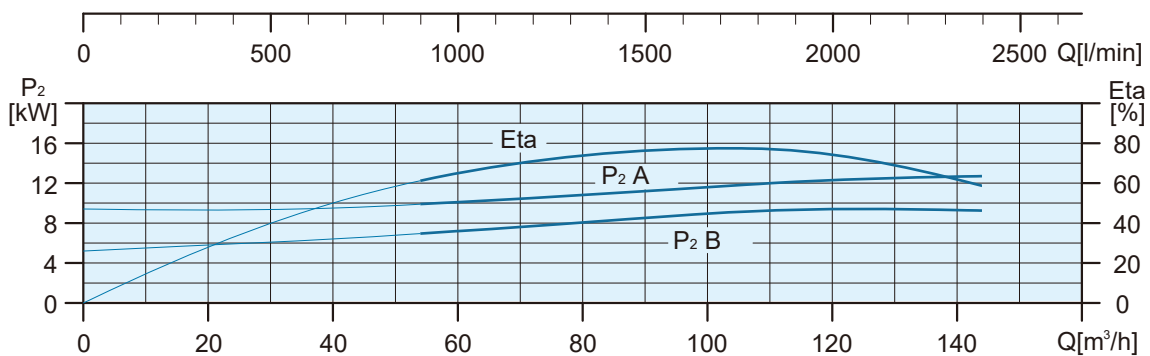
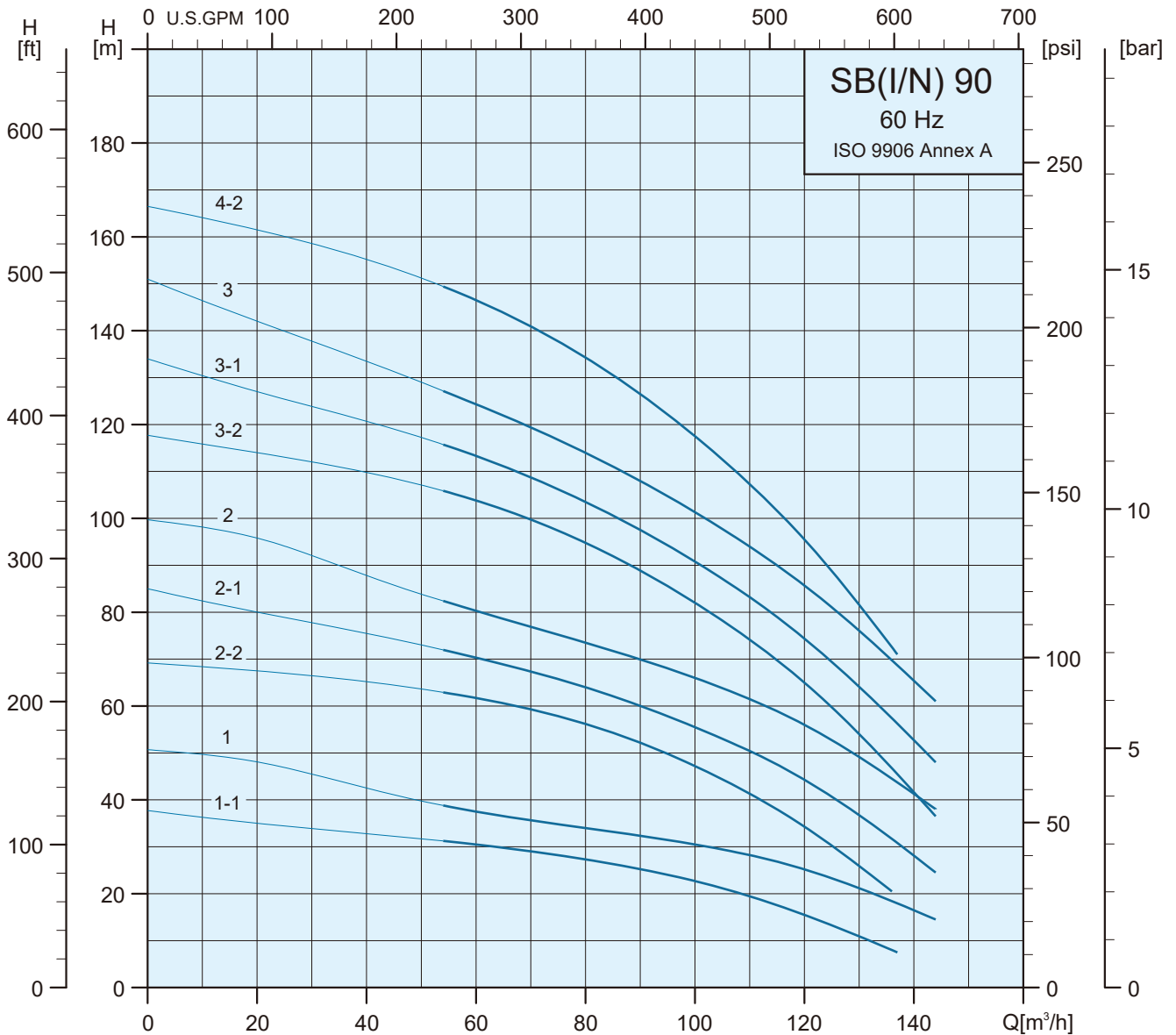

*The P₂ power of single impeller show A means regular impeller, Show B means small impeller

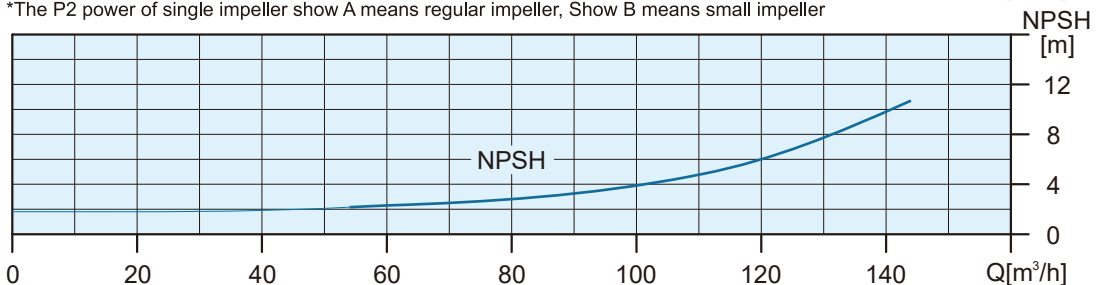

Specifications

Pump Type	Motor		Nominal Current [A]								
	P ₂		3φ		3φ		3φ		3φ		3φ
	kW	HP	△220-277V	Y380-480V	△220-240V	Y380-415V	△380-480V	Y660-830V	△380-415V	Y660-720V	△460V
SBI(N) 90-1-1	11.0	15.0	37.0 - 33.9	21.4 - 19.6	—	—	21.5 - 20.6	12.4 - 11.9	—	—	—
SBI(N) 90-1	15.0	20.0	48.5 - 40.7	28.0 - 23.5	—	—	28.5 - 24.9	16.4 - 14.3	—	—	—
SBI(N) 90-2-2	18.5	25.0	59.7 - 49.3	34.5 - 28.5	—	—	34.6 - 28.9	19.9 - 16.6	—	—	—
SBI(N) 90-2-1	22.0	30.0	70.4 - 58.5	40.7 - 33.8	—	—	41.1 - 34.3	23.7 - 19.8	—	—	—
SBI(N) 90-2	30.0	40.0	—	—	93.3 - 85.5	54.0 - 49.5	—	—	54.0 - 49.5	31.1 - 28.5	52.1
SBI(N) 90-3-2	37.0	50.0	—	—	113.0 - 103.6	65.0 - 59.5	—	—	65.0 - 59.5	37.0 - 33.9	64.0
SBI(N) 90-3-1	37.0	50.0	—	—	113.0 - 103.6	65.0 - 59.5	—	—	65.0 - 59.5	37.0 - 33.9	64.0
SBI(N) 90-3	45.0	60.0	—	—	137.0 - 125.6	79.0 - 72.3	—	—	79.0 - 72.3	45.0 - 41.3	77.6
SBI(N) 90-4-2	45.0	60.0	—	—	137.0 - 125.6	79.0 - 72.3	—	—	79.0 - 72.3	45.0 - 41.3	77.6

Dimensions and Weights

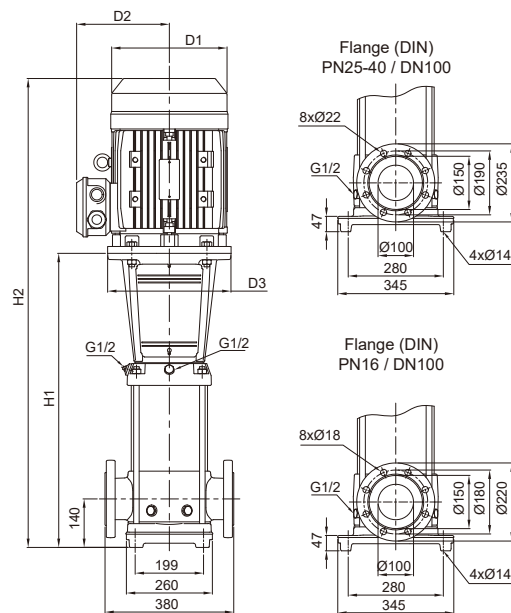

Pump Type	Dimensions (mm)					Net Weight (kg)
	DIN flange		D1	D2	D3	DIN flange
	H1	H2				
SBI(N) 90-1-1	686	1131	269	215	350	153.5
SBI(N) 90-1	686	1176	269	215	350	164.1
SBI(N) 90-2-2	778	1318	318	241	350	203.2
SBI(N) 90-2-1	778	1318	318	241	350	216.0
SBI(N) 90-2	778	1438	390	295	400	319.6
SBI(N) 90-3-2	870	1530	390	295	400	342.8
SBI(N) 90-3-1	870	1530	390	295	400	342.8
SBI(N) 90-3	870	1560	446	325	450	418.9
SBI(N) 90-4-2	962	1652	446	325	450	425.9

Performance Range

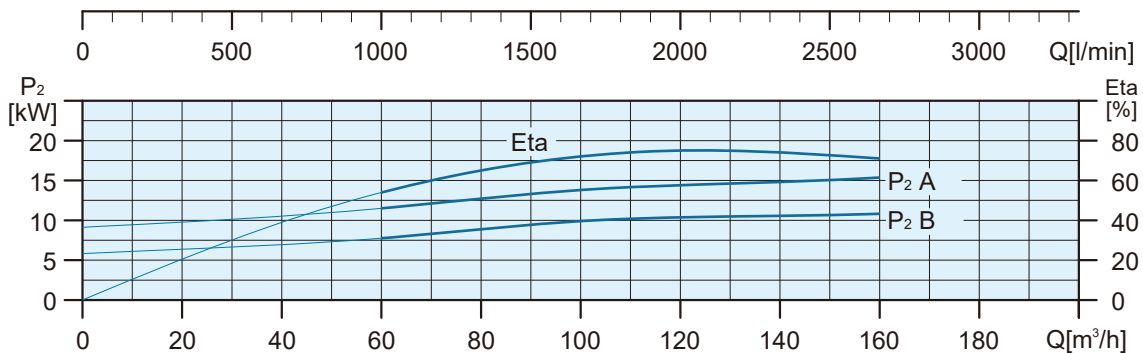
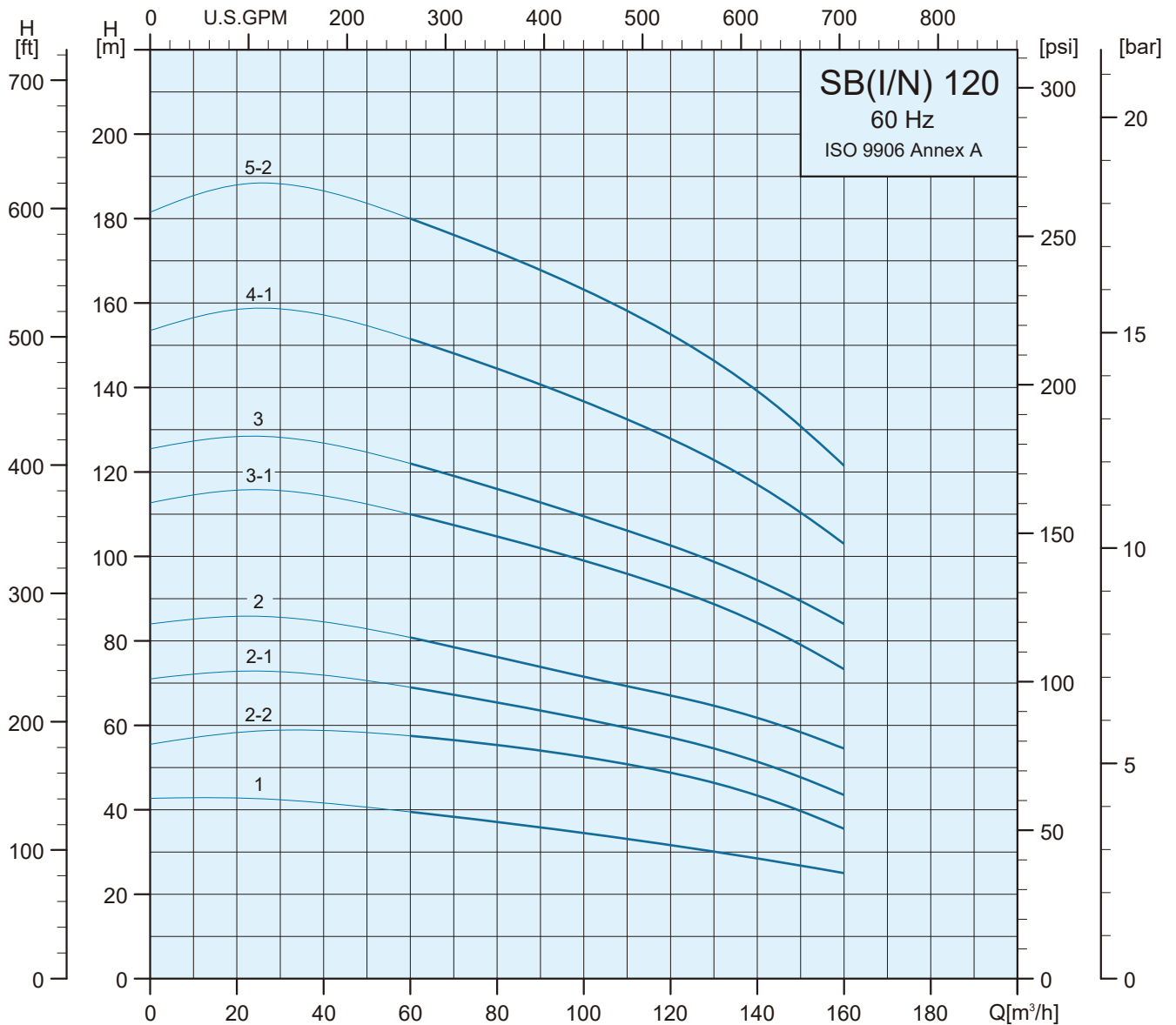

*The P₂ power of single impeller show A means regular impeller, Show B means small impeller

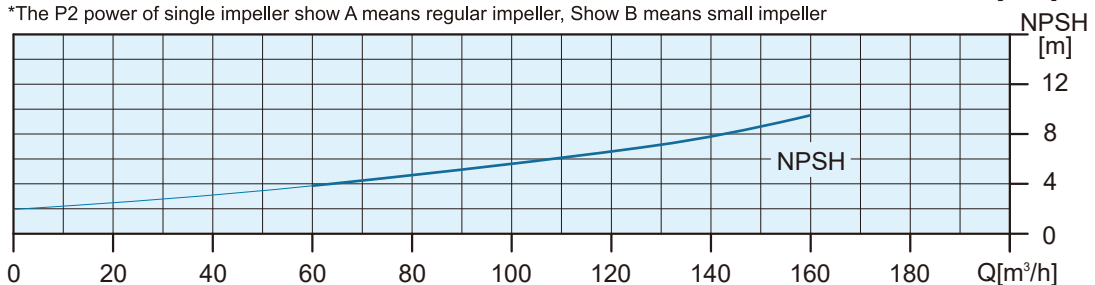

Specifications

Pump Type	Motor		Nominal Current [A]								
	P ₂		3ø		3ø		3ø		3ø		3ø
	kW	HP	Δ220-277V	Y380-480V	Δ220-240V	Y380-415V	Δ380-480V	Y660-830V	Δ380-415V	Y660-720V	Δ460V
SB 120-1	18.5	25.0	59.7 - 49.3	34.5 - 28.5	—	—	34.6 - 28.9	19.9 - 16.6	—	—	—
SB 120-2-2	30.0	40.0	—	—	93.3 - 85.5	54.0 - 49.5	—	—	54.0 - 49.5	31.1 - 28.5	52.1
SB 120-2-1	30.0	40.0	—	—	93.3 - 85.5	54.0 - 49.5	—	—	54.0 - 49.5	31.1 - 28.5	52.1
SB 120-2	37.0	50.0	—	—	113.0 - 103.6	65.0 - 59.5	—	—	65.0 - 59.5	37.0 - 33.9	64.0
SB 120-3-1	45.0	60.0	—	—	137.0 - 125.6	79.0 - 72.3	—	—	79.0 - 72.3	45.0 - 41.3	77.6
SB 120-3	55.0	75.0	—	—	168.0 - 154.0	97.0 - 88.8	—	—	97.0 - 88.8	56.0 - 51.3	94.6
SB 120-4-1	75.0	100.0	—	—	224.0 - 205.3	130.0 - 119.0	—	—	130.0 - 119.0	75.0 - 68.8	128.4
SB 120-5-2	75.0	100.0	—	—	224.0 - 205.3	130.0 - 119.0	—	—	130.0 - 119.0	75.0 - 68.8	128.4
SBI(N) 120-1	18.5	25.0	59.7 - 49.3	34.5 - 28.5	—	—	34.6 - 28.9	19.9 - 16.6	—	—	—
SBI(N) 120-2-2	30.0	40.0	—	—	93.3 - 85.5	54.0 - 49.5	—	—	54.0 - 49.5	31.1 - 28.5	52.1
SBI(N) 120-2-1	30.0	40.0	—	—	93.3 - 85.5	54.0 - 49.5	—	—	54.0 - 49.5	31.1 - 28.5	52.1
SBI(N) 120-2	37.0	50.0	—	—	113.0 - 103.6	65.0 - 59.5	—	—	65.0 - 59.5	37.0 - 33.9	64.0
SBI(N) 120-3-1	45.0	60.0	—	—	137.0 - 125.6	79.0 - 72.3	—	—	79.0 - 72.3	45.0 - 41.3	77.6
SBI(N) 120-3	55.0	75.0	—	—	168.0 - 154.0	97.0 - 88.8	—	—	97.0 - 88.8	56.0 - 51.3	94.6
SBI(N) 120-4-1	75.0	100.0	—	—	224.0 - 205.3	130.0 - 119.0	—	—	130.0 - 119.0	75.0 - 68.8	128.4
SBI(N) 120-5-2	75.0	100.0	—	—	224.0 - 205.3	130.0 - 119.0	—	—	130.0 - 119.0	75.0 - 68.8	128.4

Dimensions and Weights

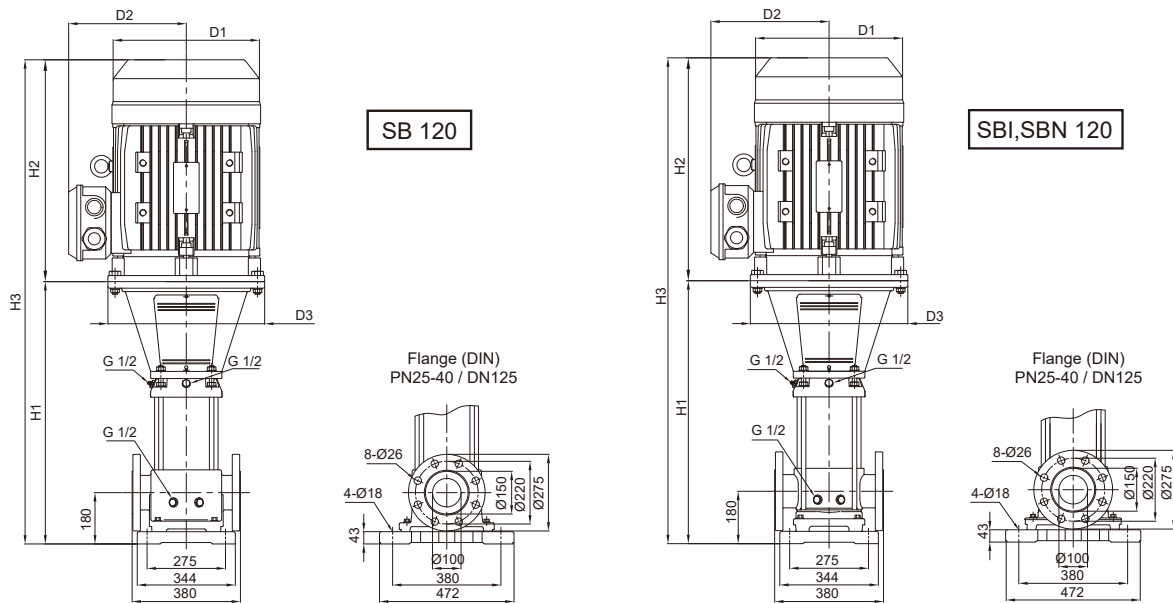

Pump Type	Dimensions (mm)						Net Weight (kg)
	DIN flange			D1	D2	D3	DIN flange
	H1	H2	H3				
SB 120-1	834	540	1374	318	241	350	239.1
SB 120-2-2	990	660	1650	390	295	400	365.5
SB 120-2-1	990	660	1650	390	295	400	365.5
SB 120-2	990	660	1650	390	295	400	383.5
SB 120-3-1	1149	690	1839	446	325	450	469.5
SB 120-3	1175	770	1945	485	355	550	589.8
SB 120-4-1	1331	845	2176	550	410	550	716.2
SB 120-5-2	1486	845	2331	550	410	550	726.2
SBI(N) 120-1	837	540	1377	318	241	350	219.2
SBI(N) 120-2-2	993	660	1653	390	295	400	349.8
SBI(N) 120-2-1	993	660	1653	390	295	400	349.8
SBI(N) 120-2	993	660	1653	390	295	400	367.9
SBI(N) 120-3-1	1152	690	1842	446	325	450	454.0
SBI(N) 120-3	1178	770	1948	485	355	550	574.4
SBI(N) 120-4-1	1334	845	2179	550	410	550	701.0
SBI(N) 120-5-2	1489	845	2334	550	410	550	711.0

Performance Range

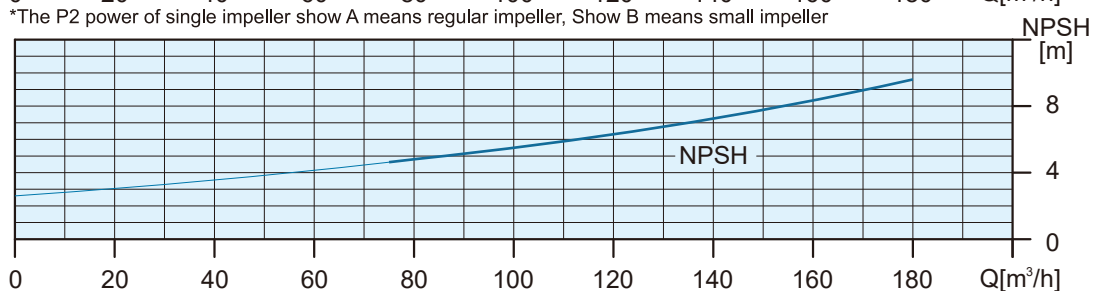
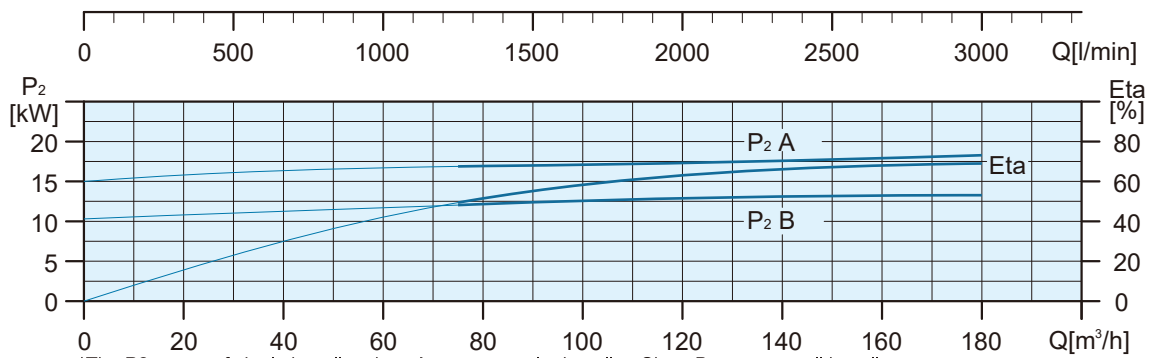
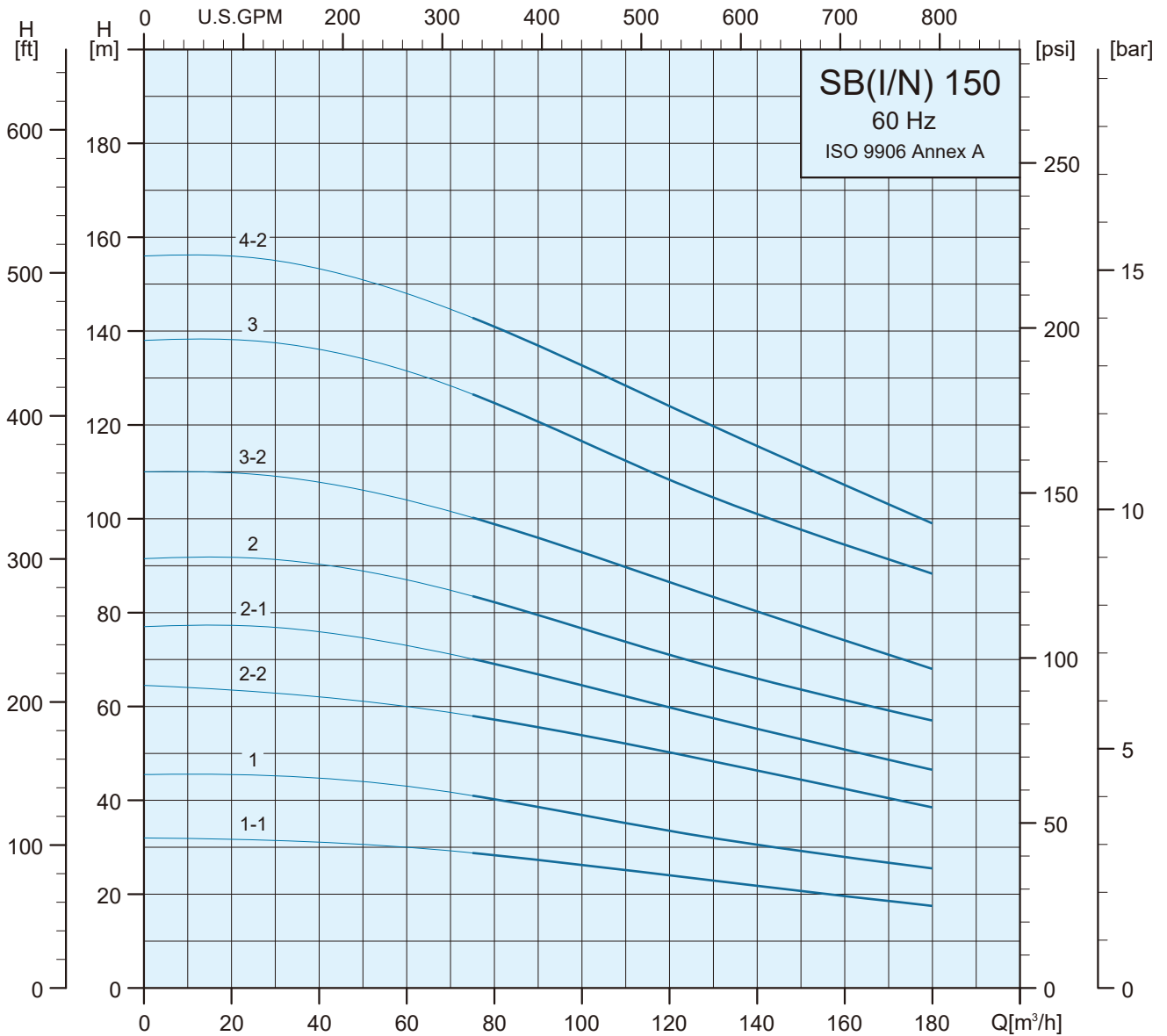

*The P2 power of single impeller show A means regular impeller, Show B means small impeller

Specifications

Pump Type	Motor		Nominal Current [A]								
	P ₂		3φ		3φ		3φ		3φ		3φ
	kW	HP	Δ220-277V	Y380-480V	Δ220-240V	Y380-415V	Δ380-480V	Y660-830V	Δ380-415V	Y660-720V	Δ460V
SB 150-1-1	18.5	25.0	59.7 - 49.3	34.5 - 28.5	—	—	34.6 - 28.9	19.9 - 16.6	—	—	—
SB 150-1	22.0	30.0	70.4 - 58.5	40.7 - 33.8	—	—	41.1 - 34.3	23.7 - 19.8	—	—	—
SB 150-2-2	30.0	40.0	—	—	93.3 - 85.5	54.0 - 49.5	—	—	54.0 - 49.5	31.1 - 28.5	52.1
SB 150-2-1	37.0	50.0	—	—	113.0 - 103.6	65.0 - 59.5	—	—	65.0 - 59.5	37.0 - 33.9	64.0
SB 150-2	45.0	60.0	—	—	137.0 - 125.6	79.0 - 72.3	—	—	79.0 - 72.3	45.0 - 41.3	77.6
SB 150-3-2	55.0	75.0	—	—	168.0 - 154.0	97.0 - 88.8	—	—	97.0 - 88.8	56.0 - 51.3	94.6
SB 150-3	75.0	100.0	—	—	224.0 - 205.3	130.0 - 119.0	—	—	130.0 - 119.0	75.0 - 68.8	128.4
SB 150-4-2	75.0	100.0	—	—	224.0 - 205.3	130.0 - 119.0	—	—	130.0 - 119.0	75.0 - 68.8	128.4
SBI(N) 150-1-1	18.5	25.0	59.7 - 49.3	34.5 - 28.5	—	—	34.6 - 28.9	19.9 - 16.6	—	—	—
SBI(N) 150-1	22.0	30.0	70.4 - 58.5	40.7 - 32.8	—	—	41.4 - 34.3	23.7 - 19.8	—	—	—
SBI(N) 150-2-2	30.0	40.0	—	—	93.3 - 85.5	54.0 - 49.5	—	—	54.0 - 49.5	31.1 - 28.5	52.1
SBI(N) 150-2-1	37.0	50.0	—	—	113.0 - 103.6	65.0 - 59.5	—	—	65.0 - 59.5	37.0 - 33.9	64.0
SBI(N) 150-2	45.0	60.0	—	—	137.0 - 125.6	79.0 - 72.3	—	—	79.0 - 72.3	45.0 - 41.3	77.6
SBI(N) 150-3-2	55.0	75.0	—	—	168.0 - 154.0	97.0 - 88.8	—	—	97.0 - 88.8	56.0 - 51.3	94.6
SBI(N) 150-3	75.0	100.0	—	—	224.0 - 205.3	130.0 - 119.0	—	—	130.0 - 119.0	75.0 - 68.8	128.4
SBI(N) 150-4-2	75.0	100.0	—	—	224.0 - 205.3	130.0 - 119.0	—	—	130.0 - 119.0	75.0 - 68.8	128.4

Dimensions and Weights

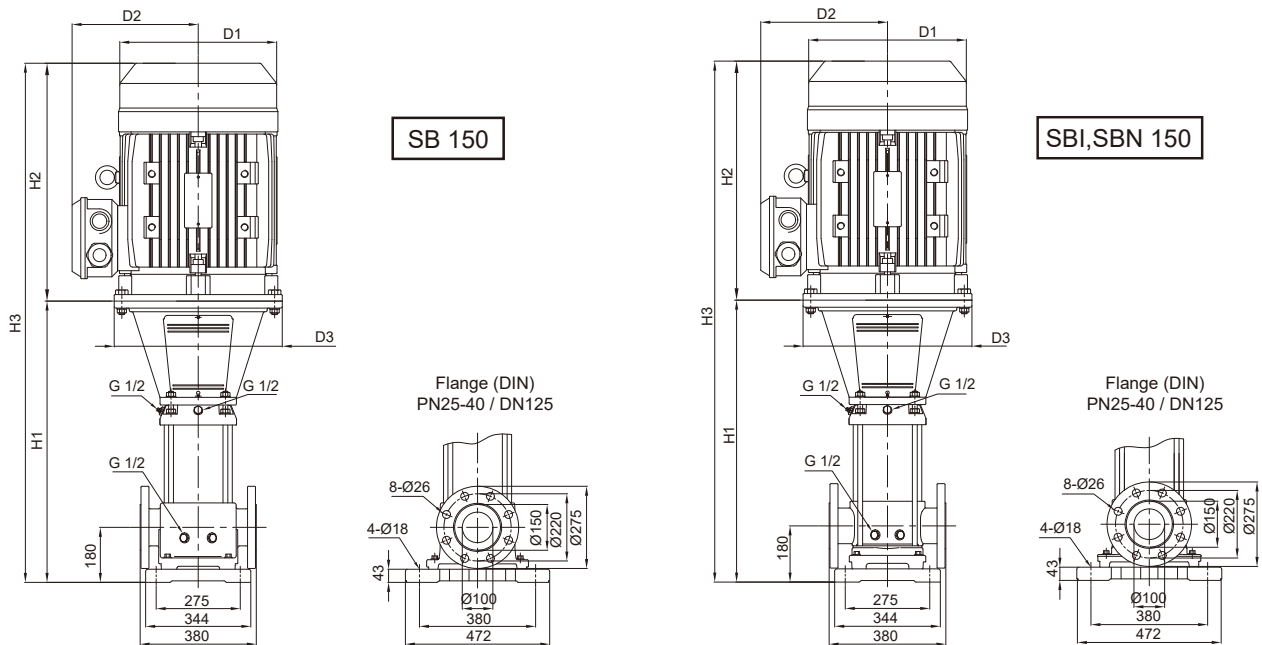

Pump Type	Dimensions (mm)						Net Weight (kg)
	DIN flange			D1	D2	D3	DIN flange
	H1	H2	H3				
SB 150-1-1	834	540	1374	318	241	350	239.0
SB 150-1	834	540	1374	318	241	350	251.8
SB 150-2-2	990	660	1650	390	295	400	365.4
SB 150-2-1	990	660	1650	390	295	400	383.4
SB 150-2	994	690	1684	446	325	450	459.5
SB 150-3-2	1175	770	1945	485	355	550	589.7
SB 150-3	1175	845	2020	550	410	550	706.2
SB 150-4-2	1331	845	2176	550	410	550	716.2
SBI(N) 150-1-1	837	540	1377	318	241	350	222.7
SBI(N) 150-1	837	540	1377	318	241	350	235.7
SBI(N) 150-2-2	993	660	1653	390	295	400	349.1
SBI(N) 150-2-1	993	660	1653	390	295	400	367.1
SBI(N) 150-2	997	690	1687	446	325	450	443.3
SBI(N) 150-3-2	1178	770	1948	485	355	550	573.5
SBI(N) 150-3	1178	845	2023	550	410	550	690.1
SBI(N) 150-4-2	1334	845	2179	550	410	550	699.2

SB-200

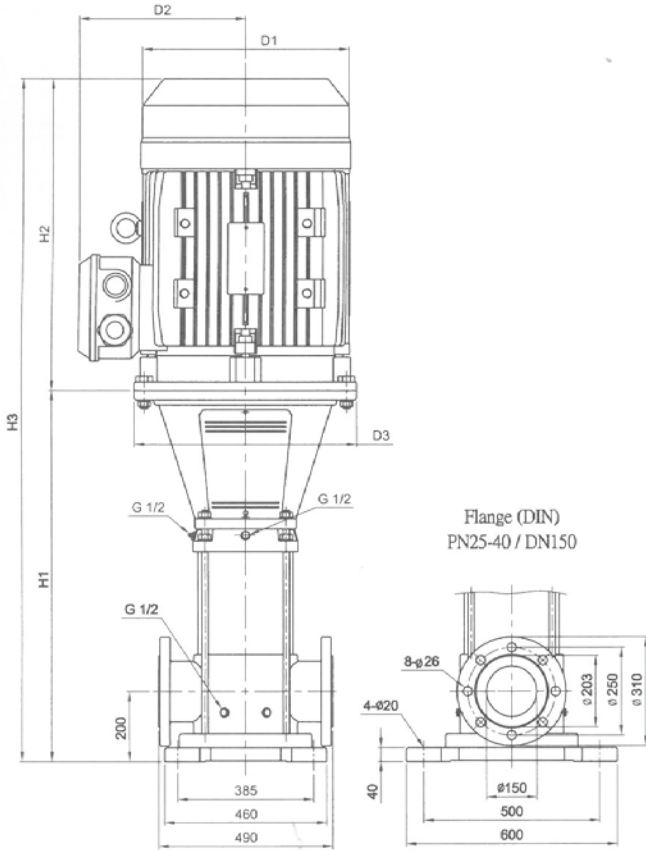

SBI(N)-200

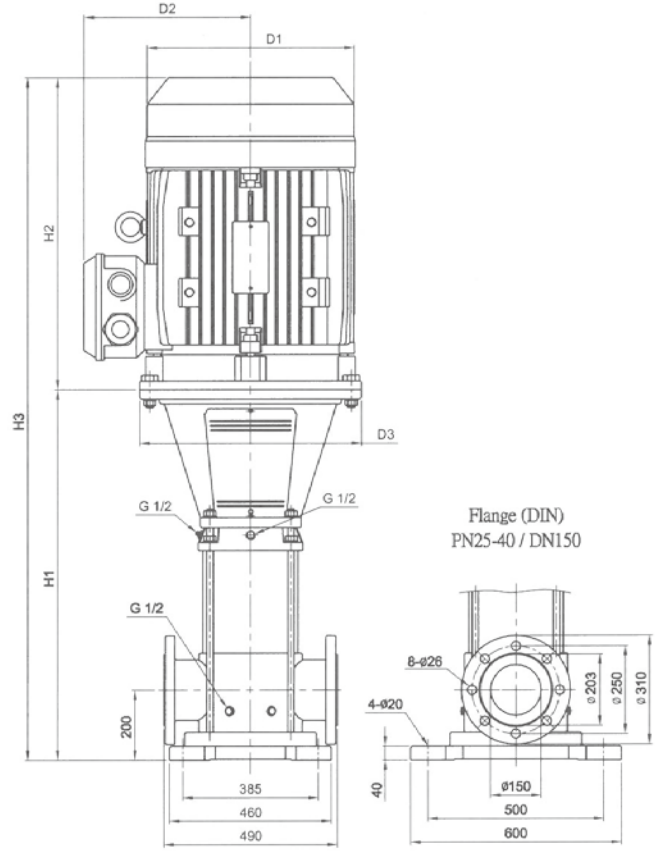

Pump Type	Dimensions (mm)					
	DIN flange			D1	D2	D3
	H1	H2	H3			
SB 200-1	898	660	1558	390	295	400
SB 200-2-2	1104	770	1874	485	355	550
SB 200-2-1	1104	845	1949	550	410	550
SB 200-2	1104	845	4949	550	410	550
SB 200-3-2	1280	891	2171	547	410	550
SB 200-3-1	1280	1040	2320	620	545	660
SB 200-3	1280	1040	2320	620	545	660
SBI(N) 200-1	898	660	1558	390	295	400
SBI(N) 200-2-2	1104	770	1874	485	355	550
SBI(N) 200-2-1	1104	845	1949	550	410	550
SBI(N) 200-2	1104	845	1949	550	410	550
SBI(N) 200-3-2	1280	891	2171	547	410	550
SBI(N) 120-3-1	1280	1040	2320	620	545	660
SBI(N) 200-3	1280	1040	2320	620	545	660

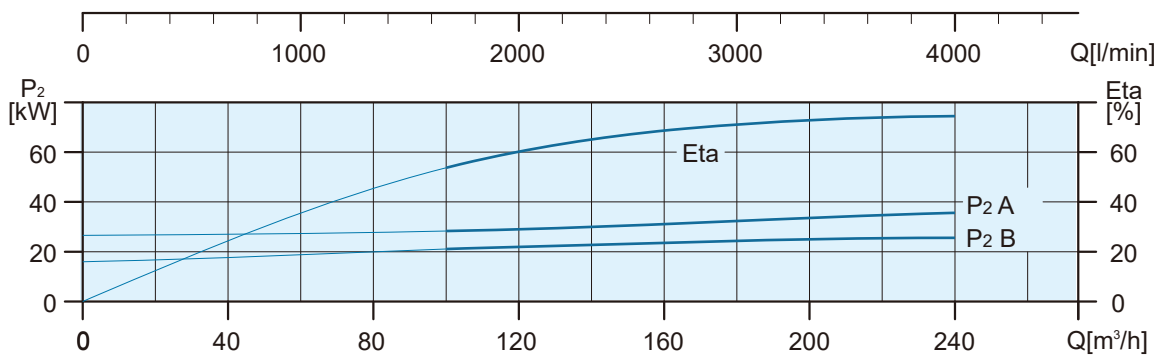
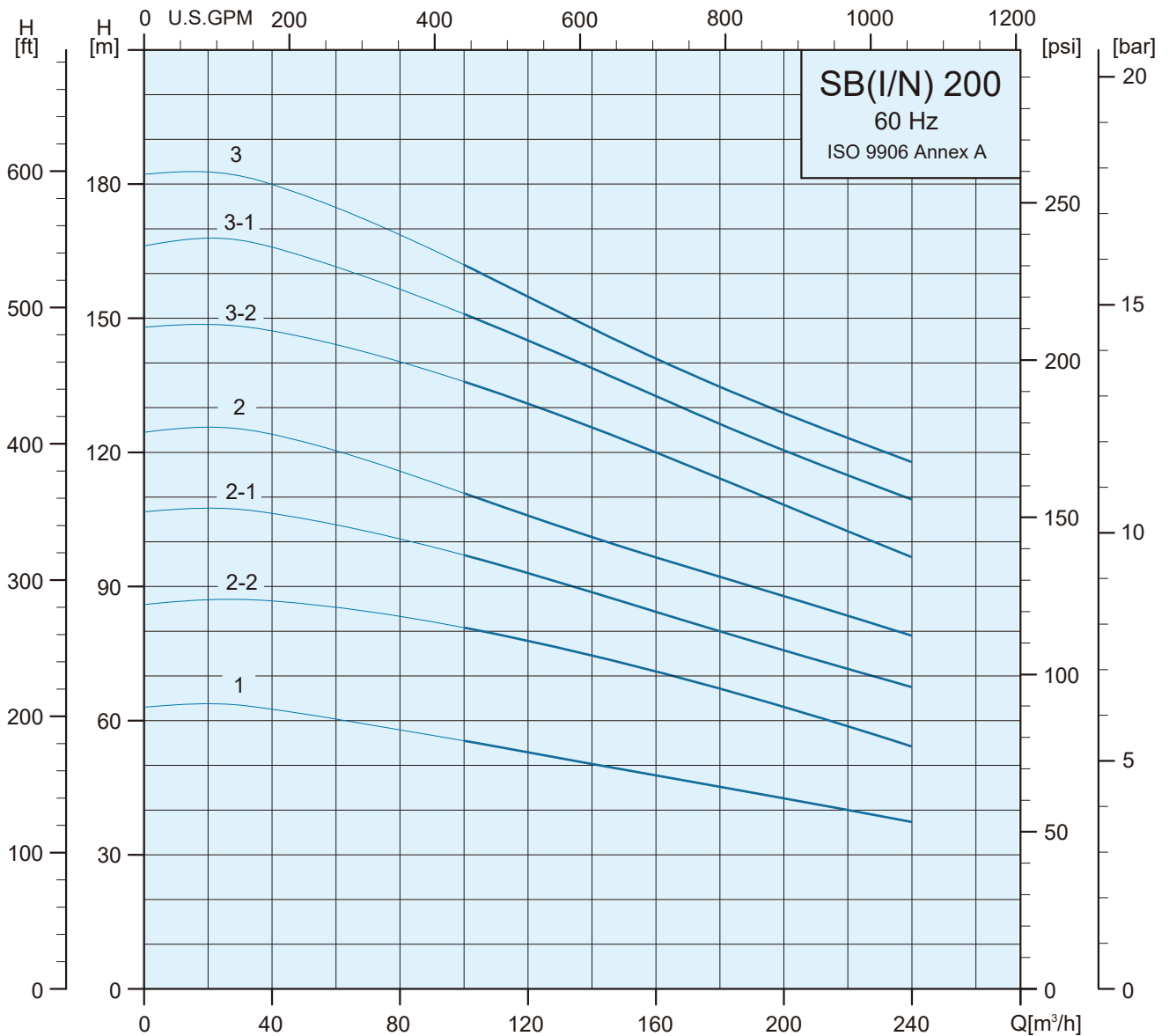

*The P2 power of single impeller show A means regular impeller, Show B means small impeller

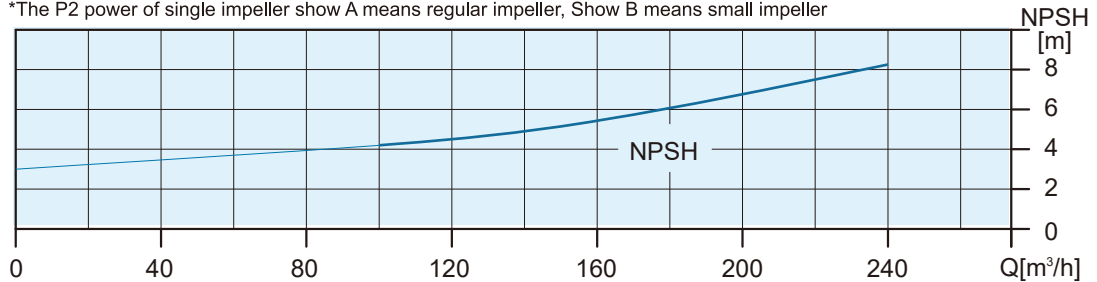

Pipework Connections

For pipework connection, various sets of counter flanges and couplings are available.

Counter flanges for SB(I/N)

A set consists of one counter flange, one gasket, bolts, nuts, washers

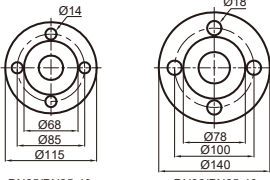
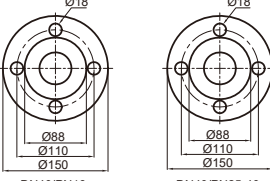
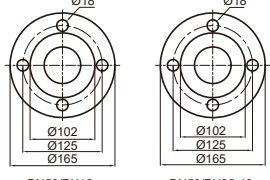
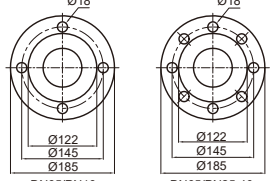
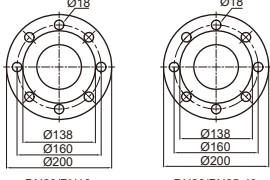
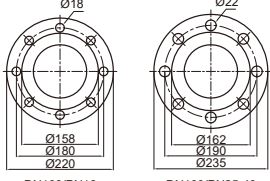
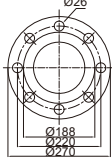
Counter flange	Pump Type	Nominal Rated Diameter	Description	Rated Pressure	Pipework Connection
 <p>DN25/PN25-40 DN32/PN25-40</p>	SB(I/N) 1 SB(I/N) 3 SB(I/N) 5	DN 25	Threaded	25-40 bar	Rp 1"
		DN 32	Threaded	25-40 bar	Rp 1 1/4"
 <p>DN40/PN16 DN40/PN25-40</p>	SB(I/N) 10	DN 40	Threaded	16 bar	Rp 1 1/2"
				25-40 bar	
 <p>DN50/PN16 DN50/PN25-40</p>	SB(I/N) 15 SB(I/N) 20	DN 50	Threaded	16 bar	Rp 2"
				25-40 bar	
 <p>DN65/PN16 DN65/PN25-40</p>	SB(I/N) 32	DN 65	Threaded	16 bar	Rp 2 1/2"
				25-40 bar	
 <p>DN80/PN16 DN80/PN25-40</p>	SB(I/N) 45	DN 80	Threaded	16 bar	Rp 3"
				25-40 bar	
 <p>DN100/PN16 DN100/PN25-40</p>	SB(I/N) 64 SB(I/N) 90	DN 100	Threaded	16 bar	Rp 4"
				25-40 bar	
 <p>DN125/PN25-40</p>	SB(I/N) 120 SB(I/N) 150	DN 125	Threaded	25-40 bar	Rp 5"

The material of counter is in Steel(S45C), SS 304 and SS 316 available.

Victaulic couplings for SBI(N)

A set consists of two coupling halves, one gasket, one pipe stud(threaded), bolts and nuts

Victaulic Connections	Pump Type	Coupling & Pipe Stud	Max Pressure	Description	Rubber	Pipework Connection
	SBI 1 / 3 / 5	304 SS	80 bar	Threaded	EPDM	R 1 1/4"
	SBN 1 / 3 / 5	316 SS				
	SBI 10 / 15 / 20	304 SS	70 bar			R 2"
	SBN 10 / 15 / 20	316 SS				

Oval flanges for SB(I/N)

A set consists of one OVAL flange, one gasket, two bolts

Counter flange	Description	Max Pressure	Gasket	Pipework Connection
<p>SB 1,3 SBI(N) 1,3</p>	Threaded	16bar	Non Asbestos	Rp 1"
<p>SB 5 SBI(N) 5</p>	Threaded	16bar	Non Asbestos	Rp 1 1/4"
<p>SB 10 SBI(N) 10</p>	Threaded	16bar	Non Asbestos	Rp 1 1/2"
<p>SB 15,20 SBI(N) 15,20</p>	Threaded	10bar	Non Asbestos	Rp 2"

The material of counter is in Steel(S45C), SS 304 and SS 316 available.

